

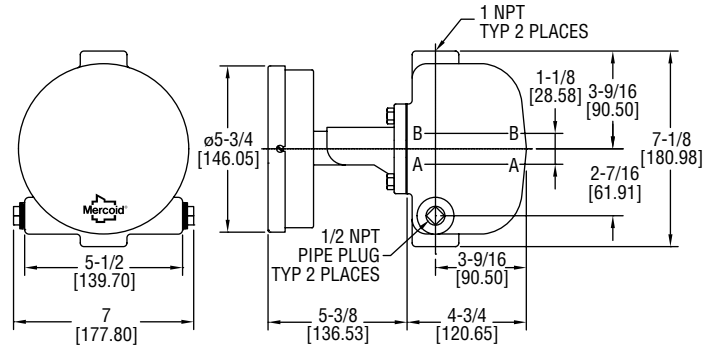

Series 123/125 Boiler Water Level Control

Specifications - Installation and Operating Instructions



The **SERIES 123 & 125** Boiler Water Level Controls are designed for boiler applications, the 123 is primarily used for low water cut-off or feed-water control. The 125 offers the same long lasting service with a direct action mercury switch movement that provides a close deadband where needed.

FEATURES/BENEFITS

- Special snap action switch mechanism options eliminates frequent operation due to surging water level
- Transparent cover provides convenient visible operation of the switch
- Flanged chamber for easy clean out and replacement of float or switch mechanism without removing the unit from piping

APPLICATIONS

- Boiler Low Water Cut-Off
- Boiler Feed-Water Control
- Condensate Tanks
- Deaerators

MOUNTING

Install control so that lower part of float casting designated as "C-C" (Figure 1) is in line with lower glass gauge fitting. "C-C" should at no time be installed below crown sheet of boiler. Use 1" pipe for both steam and water equalizers. Provide valve below control for blowing out sludge periodically as shown in Figure 2.

SPECIFICATIONS

Service: Compatible liquids. Cast iron is not for use with lethal or flammable substances either liquid or gaseous.
Wetted Materials: Body: Cast iron; Float: 304 SS; Trim and packing gland: Brass; Packing: Carbon; Body gasket: Carbon.
Temperature Limit: 365°F (185°C).
Pressure Limit: 150 psig (10.34 bar).
Enclosure Rating: General purpose. Optional weatherproof.
Switch Type: SPDT snap switch or mercury switch. Optional DPDT or two stage.
Electrical Rating: Snap switch: 15 A @ 120/240/480 VAC, 0.5 A @ 120 VDC resistive, 0.25 A @ 240 VDC resistive; Mercury switch: 4 A @ 120 VAC/DC, 2 A @ 240 VAC/DC.
Electrical Connections: Screw terminal.
Conduit Connection: 7/8" (22.23 mm) hole for 1/2" (12.7 mm) conduit.
Process Connections: 1" female NPT.
Mounting Orientation: Vertical.
Deadband: Approximately 1-1/2" (38.1 mm).
Specific Gravity: 0.88 min.
Options: Manual reset.
Weight: 20 lb (9.1 kg).
Agency Approvals: CSA, UL. (Snap switch is not rated).

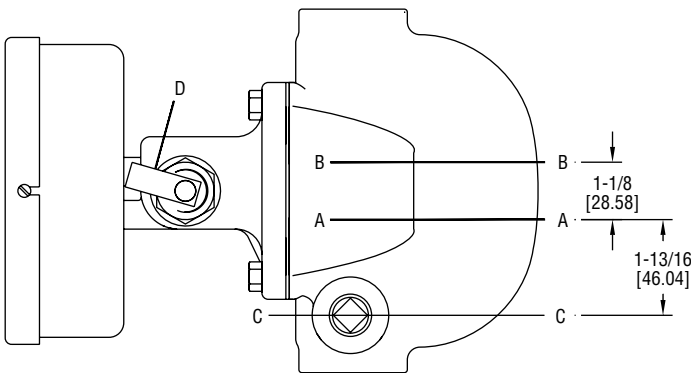

Figure 1

ADJUSTMENTS

Adjustments are factory set and cannot be changed. Type 123 opens circuit as liquid level lowers and is set to cut out at level "A-A" and cut in at level "B-B". Type 123-3 opens circuit as liquid level rises and is set to cut in at level "A-A" and cut out at level "B-B".

Note: Not for use with lethal or flammable substances, either liquid or gaseous.

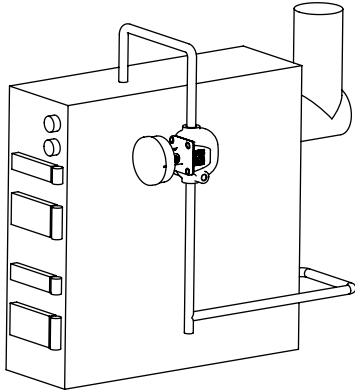

Figure 2
Typical Installation of Type 123 Low Water Control

CARE OF PACKING GLAND

All low water and pump feed controls require a reasonable amount of attention to insure dependable operation. The packing gland must be periodically tightened to prevent leakage. Should leaks occur, screw down on knurled packing gland nut until leak stops (use wrench if necessary). Next move operating arm up and down several times by hand and then back off nut one-half turn.

When repacking of the gland is required we recommend that standard packing be ordered from the factory.

To insure satisfactory operation at all times, this control should be checked daily. The engineer in charge should move the operating arm "D" up and down several times by hand, to insure free operation of the shaft. When boiler compounds are used, the float bowl should be blow out periodically.

CAUTION: When removing old or inserting new packing be careful not to gouge or score the operating shaft.

WIRING

Rigid conduit must not be attached to case. Use a short strip of BX to relieve control of conduit expansion and contraction strains. When fitting BX cable connector into case, be careful not to damage instrument mechanism.

The lead wires should be cut short and directly connected to the terminal posts.

Excessive lengths of wire crowded into the case interfere with the free movement of the mechanism and cause erratic operation.

Where control is directly connected into load circuit it must be connected in hot side of line. If in doubt as to which is the hot wire, connect one wire of a test lamp to a water pipe, or some other suitable ground. The lamp will light when the other wire (of test lamp) is connected to the hot wire.

Fuses installed in line switch should not exceed 10 amperages at 115 volts or 5 amperes at 230 volts.

ELECTRICAL RATING:

Furnished standard to withstand 10 amp, 115 V, 5 amp, 230 V either A.C. or D.C. Motor rating, 1 H.P. Repulsion-induction ½ H. P. Split Phase or D.C.

CAUTIONS-Note Carefully.

Keep cover closed and do not attempt to disconnect or change any parts. Do not overload. Note electrical rating on nameplate and be sure total current passing through switch is within this rating. Do not tamper with switch wires. Position of these wires is essential to proper operation. Tampering with these wires will void warranty.

CONTROL MOVEMENT MUSE NOT BE OILED

Note: Cold shock or water hammer must be avoided, as this condition may damage the float and prevent proper operation of control.

MAINTENANCE/REPAIR

Upon final installation of the Series 123, no routine maintenance is required. The Series 123 is not field serviceable and is not possible to repair the unit. Field repair should not be attempted and may void warranty.

WARRANTY/RETURN

Refer to "Terms and Conditions of Sale" in our catalog and on our website. Contact customer service to receive a Return Goods Authorization number before shipping the product back for repair. Be sure to include a brief description of the problem plus any additional application notes.

