

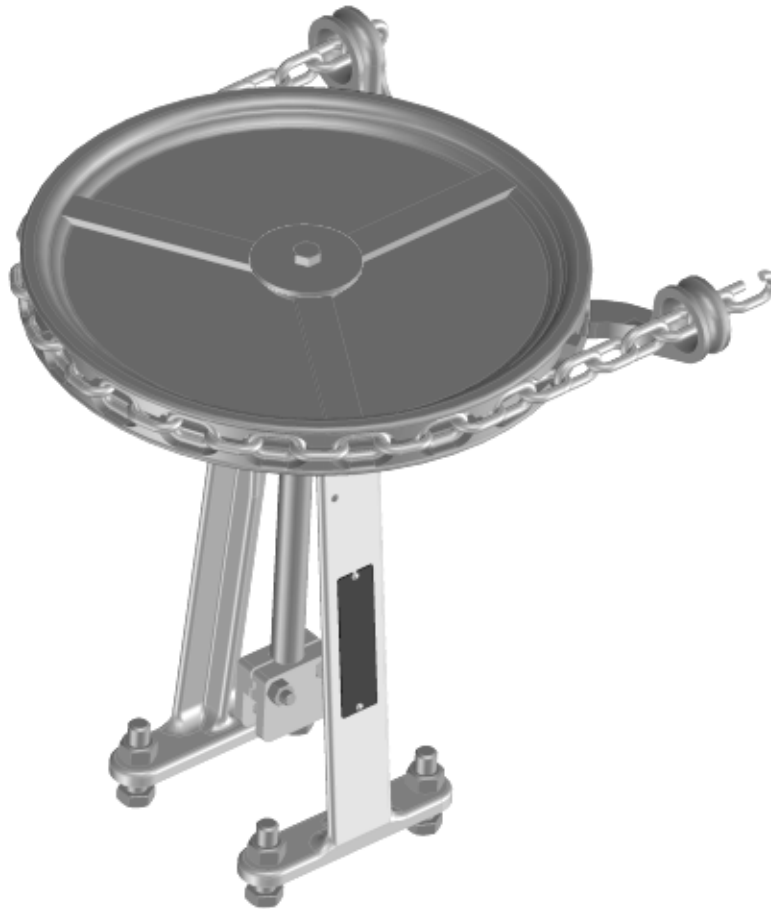

# MANUAL ACTUATOR FOR KNIFE GATE VALVES



Instruction **D10079**

November 2013

# DeZURIK

## Manual Actuator for Knife Gate Valves

---

### Instructions

These instructions are intended for personnel who are responsible for the installation, operation and maintenance of your manual actuator.

### Safety Messages

All safety messages in the instructions are flagged with the word Caution, Warning or Danger. These messages must be followed exactly to avoid equipment damage, personal injury or death.

Safety label(s) on the product indicate hazards that can cause equipment damage, personal injury or death. If a safety label becomes difficult to see, or if a label has been removed, please DeZURIK for replacement.



#### **WARNING!**

**Personnel involved in the installation or maintenance of valves should be constantly alert to potential emission of process material and take appropriate safety precautions. Always wear suitable protection when dealing with hazardous process materials. Handle valves which have been removed from service with the assumption of process material within the valve.**

---

### Inspection

Your manual actuator has been packaged to provide protection during shipment. Carefully inspect the unit for damage upon arrival and file a claim with the carrier if damage is apparent.

### Parts

Recommended spare parts are listed on the assembly drawing. These parts should be stocked to minimize downtime.

Order parts from your DeZURIK sales representative, or directly from DeZURIK. When ordering parts, please include the 7-digit part number and 4-digit revision number (example: **9999999R000**) located on the data plate attached to the valve assembly. Also include the part name, the assembly drawing number, the balloon number and the quantity stated on the assembly drawing.

### DeZURIK Service

DeZURIK service personnel are available to install, maintain and repair all DeZURIK products. DeZURIK also offers customized training programs and consultation services. For more information, contact your local DeZURIK sales representative or visit our website at [www.dezurik.com](http://www.dezurik.com).

### Lubrication

Lubricate the fitting near the top of the yoke monthly with a lithium-based grease.

### Operation

#### **Lever Actuator**

1. Loosen the lock screw near the top of the yoke.
2. Move the lever to open or close the valve.
3. Tighten the lock screw to hold the valve in the desired position.

#### **Handwheel, Chainwheel and Bevel-Gear Actuators**

Rotate the handwheel or chainwheel clockwise to close the valve.

**Note:** There is an arrow cast on the wheel to indicate direction of rotation.

### Removing Actuator

1. Close the valve.
2. Disconnect the stem from the gate by removing the two screws and nuts.
3. Remove the screws securing the actuator yoke to the valve, then separate the actuator from the valve.

### Actuator Installation

1. Close the valve.
2. Set the actuator on the valve and secure it in place with the screws.
3. Connect the stem to the gate with two screws and nuts.

### Mounting Handwheel

#### **2–12" C-Series, KBD, KGC, KGL, KGU, KGS, KSV and KUL Valves**

Two Spirol® pins are used to connect the handwheel to the yoke sleeve. The use of any other type of pin will result in actuator failure.

1. Rotate the yoke sleeve until the flange on the yoke sleeve touches the yoke.
2. Place the thrust washer and the wave washer over the yoke sleeve.
3. Set the handwheel in place. Turn the wheel so the holes in the wheel line up with the pin ways in the yoke sleeve.
4. Insert a 5/16"-diameter bolt in one of the holes.

**Note:** This will prevent misalignment. If the holes are not aligned the pin ways in the yoke sleeve could be damaged by the Spirol® pins.



#### **WARNING!**

This actuator has been designed to use only heavy-duty Spirol® brand pins. The use of any other type of pin will result in actuator failure. See Figure 1.

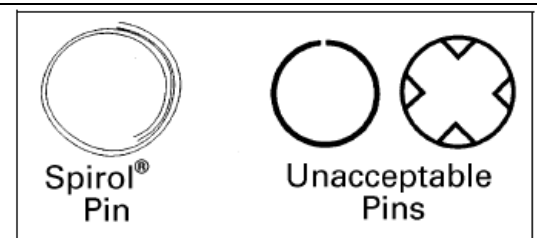

**FIGURE 1– Pin Designs**

5. Drive a Spirol® pin into the remaining hole in the wheel until the end of the pin is flush with the outer surface of the wheel.
6. Remove the 5/16" bolt installed in Step 4, and drive a Spirol® pin into the hole.
7. Lubricate the actuator as described in the LUBRICATION section of these instructions.

### Mounting Chainwheel

#### 2–12" C-Series, KBD, KGC, KGL, KGU, KGS, KSV and KUL Valves

Two Spirol® pins are used to connect the chainwheel to the yoke sleeve. The use of any other type of pin will result in actuator failure.

1. Rotate the yoke sleeve until the flange on the yoke sleeve touches the yoke.
2. Place the thrust washer and the wave washer over the yoke sleeve.
3. Set the chainwheel in place. Turn the wheel so the holes in the wheel line up with the pin ways in the yoke sleeve.
4. Insert a 5/16"-diameter bolt in one of the holes.

**Note:** This will prevent misalignment. If the holes are not aligned the pin ways in the yoke sleeve could be damaged by the Spirol® pins.



#### WARNING!

This actuator has been designed to use only heavy-duty Spirol® brand pins. The use of any other type of pin will result in actuator failure. See Figure 2.

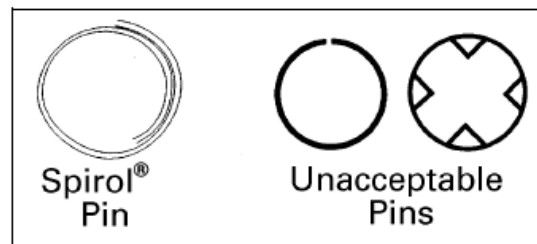

FIGURE 2—Pin Designs

5. Drive a Spirol® pin into the remaining hole in the wheel until the end of the pin is flush with the outer surface of the wheel.
6. Remove the 5/16" bolt installed in Step 4, and drive a Spirol® pin into the hole.

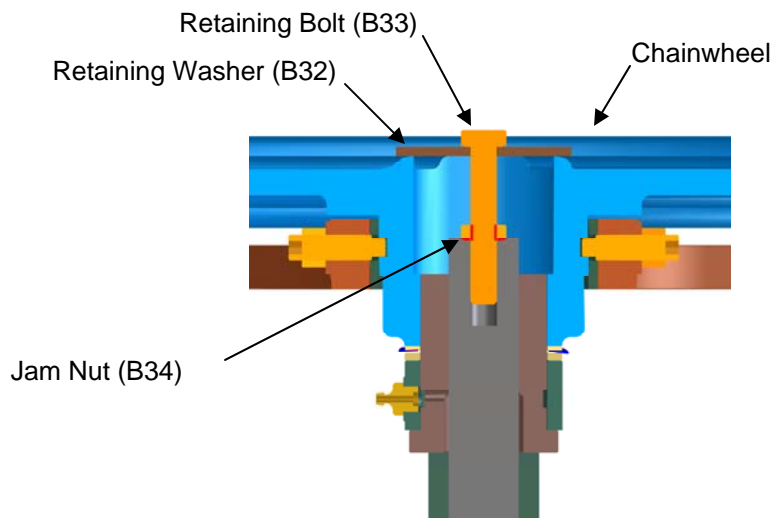

FIGURE 3—Detailed View of Chainwheel Retaining Components on 2-12" Valves

\*Spirol® is a registered trademark of CEM Corporation

### Mounting Chainwheel continued

7. As shown in Figure 3, insert the large hex-head retaining bolt (B33) through the 2.5-inch retaining washer (B32) and stake the washer to the head of the bolt. This keeps the washer from sliding down the shaft of the bolt when the valve is open (when the stem is extended upward).
8. Turn the 3/8-16 jam nut (B34) onto the retaining bolt/washer assembly. Turn the nut on far enough to allow the bolt to be fully inserted into the valve stem (detailed in the next step).
9. Turn the retaining bolt assembly into the tapped hole on the valve stem until it bottoms out.
10. Tighten the jam nut firmly against the valve stem. This prevents the retaining bolt assembly (and the chainwheel) from being dislodged if the two Spirol® pins are damaged or fatigued.
11. Lubricate the actuator as described in the LUBRICATION section of these instructions.

### Mounting Handwheel or Chainwheel on Large Valves

#### ***14-24" KGC, KGL, KGU, KGS and KUL Valves only***

1. Rotate the yoke sleeve until the flange on the yoke sleeve touches the yoke.
2. Place the thrust washer over the yoke sleeve.
3. Install the woodruff key in the yoke sleeve keyseat.
4. Align the keyway in the wheel with the key in the yoke sleeve, then slide the wheel into the yoke sleeve until the wheel contacts the shoulder on the yoke sleeve.
5. On valves with a chainwheel actuator, slide the chain guide over the yoke sleeve so the guide loops are directly under the chainwheel.
6. Screw the nut onto the yoke sleeve to retain the wheel.
7. Pin the nut to the yoke sleeve.