

MODEL VS_(L)

ANSI B16.5 Slip-On, Raised Face Flanges - Class 150 or 300

DESCRIPTION AND GENERAL PERFORMANCE SPECIFICATIONS

The V-Cone® flowmeter is a patented, differential pressure type flow measurement device. A cone is positioned in the center of the pipe to increase the velocity of the flowing fluid and create a differential pressure. This pressure difference can be measured and used to accurately interpret flowrate. Two taps are provided on every V-Cone to allow sensing of the high and low pressures. A typical V-Cone application can follow these general performance specifications:

- Accuracy: up to ±0.5% of rate
- Repeatability: ±0.1%
- Turndown: 10:1
- Standard Betas: 0.45 through 0.85
- Headloss: Percentage of differential pressure produced varies with beta ratio.
- Installation: Typically 0-3 diameters upstream and 0-1 diameters downstream.

* Each V-Cone is sized for the intended application. Specific performance ratings must be obtained through the sizing process.

Model VS Bulletins
ANSI B16.5 Slip-on, RF Flanges
24509-32 Class 150 or 300
24509-33 Class 600 or 900
24509-34 Class 125 or 250



The V-Cone is manufactured under a quality management system that is certified to ISO 9001:2008.

MODEL VS_(L) DIMENSIONS

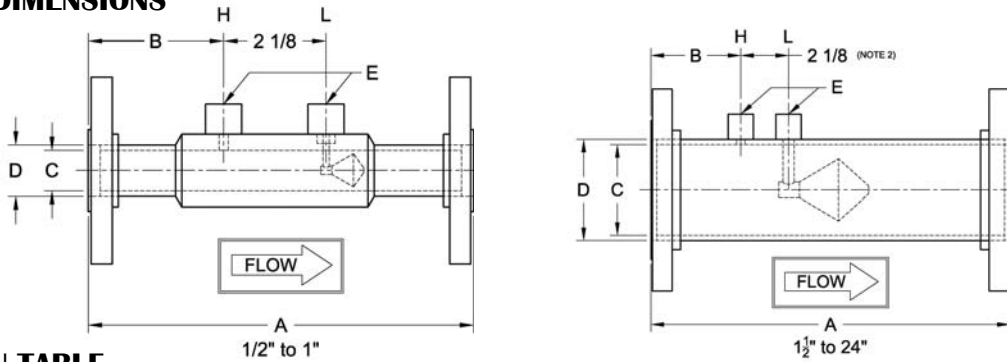

DIMENSION TABLE

Size	A (Note 1)		B		C-Stainless (Note 2)		C-Carbon (Note 2)		D		E (Note 2)
	inch	mm	inch	mm	inch	mm	inch	mm	inch	mm	NPT
1/2	8	203	2.9	75	0.622	15.8	-	-	0.84	21.3	1/4
3/4	8	203	2.9	75	0.824	20.9	-	-	1.05	26.7	1/4
1	8	203	2.9	75	1.049	26.64	-	-	1.315	33.4	1/4
1 1/2	10	254	3	76	1.645	41.78	-	-	1.9	48.3	1/4
2	12	305	3.5	89	2.104	53.44	-	-	2.375	60.3	1/2
2 1/2	12	305	3.5	89	2.504	63.60	-	-	2.875	73.0	1/2
3	14	356	3.5	89	3.104	78.84	-	-	3.5	88.9	1/2
4	16	406	4	102	4.090	103.8	-	-	4.5	114	1/2
6	22	559	4.25	108	6.065	154.1	6.065	154.1	6.625	168	1/2
8	26	660	5	127	7.981	202.7	7.981	202.7	8.625	219	1/2
10	28	711	5	127	10.02	254.5	10.02	254.5	10.75	273	1/2
12	30	762	5.25	133	12.00	304.8	11.94	303.3	12.75	323	1/2
14	30	762	6	152	13.25	336.6	13.13	333.5	14	355	1/2
16	30	762	6	152	15.25	387.4	15.00	381.0	16	406	1/2
18	32	813	6	152	17.25	438.2	17.25	438.2	18	457	1/2
20	36	914	6	152	19.25	489.0	19.25	489.0	20	508	1/2
24	48	1219	10	254	23.25	590.6	23.25	590.6	24	609	1/2

1. Overall length (A) tolerance varies with line size: 1/2" to 1", ±1/16" (±2mm); 1 1/2" to 10", ±1/8" (±4mm); 12" to 24", ±3/16" (±6mm).
2. Typical values shown.
3. Wall pressure ports are required for vertical up flow applications.



CONFIGURATION SHEET

MODEL NUMBER CONFIGURATION VS(L)

Type	Size	Materials‡		Pipe Schedule	End Connections	Fittings	
VS							
0A	½"	Q	S304	A	10	03 CL 150 RF SO 04 CL 300 RF SO	N NPT S Socket
0B	¾"	L	S304L	B	20		
01	1"	A	S316L	D	Std	‡Other materials can include: HASTELLOY C-276 S321H DUPLEX 2205 INCONEL 625 CHROMEMOLY P22/P11 PVC MONEL K400/K500 PTFE CARBON STEELS A350, A333, API5L, A106B	Several types of fittings
0C	1½"	P	CPVC	E	40		
02	2"	N	S304 Tube, Cone, Support & Couplings	F	80		
0D	2½"		CS Steel Flanges	J	100		
03	3"		Flanges painted	K	120		
04	4"	S	CS Tube & Flanges	L	140		
06	6"		S304 Cone, Support, & Couplings	G	160		
08	8"		Epoxy Coated Blue (excluding cone)	H	XXS		
10	10"	U	CS Tube & Flanges	M	10S		
12	12"		S304 Cone, Support, & Couplings	P	XS		
14	14"		Coating / Painting Per Customer Req.				
16	16"						
18	18"						
20	20"						
24	24"						

Example: VS06QE03N V-Cone 6 inch line size, S304, schedule 40 pipe, ANSI CL 150 RF slip on flanges, ½" NPT fittings

STANDARD PIPE SCHEDULES

Stainless Steel		Carbon Steel	
Size	Std.	Size	Std.
½" to 10"	E	6" to 16"	E
12" and up	D	18" and up	D

Meters 6" and smaller utilize seamless pipe.
Meters 8" and larger utilize welded pipe.

ABBREVIATIONS

ASME	American Society of Mechanical Engineers		
NPT	National pipe taper		
SS	Stainless steel	RF	Raised Face
CS	Carbon steel	SO	Slip On

Technical questions can be answered through a local representative or through our application engineers.

MANUFACTURING STANDARDS

McCrometer's welders and welding procedures are qualified in accordance with ASME Section IX. All meters are visually inspected for weld defects. Specific customer requirements can be complied with upon request.

The welding can be in accordance with:

- ASME Section VIII
- ASME B31.1
- ASME B31.3

Non-destructive testing can include:

- Hydrostatic Pressure Testing
- Penetrant Examination
- Radiographic Examination
- Positive Material Inspection
- Magnetic Particle Examination

REPRESENTED BY:

