



MODEL MW800 / MM800

RIGHT ANGLE FLOWMETER

DESCRIPTION

Model MW800/MM800 Right Angle Meters have a standard coating of fusion-bonded epoxy. These models are manufactured to comply with the applicable provisions of the American Water Works Association Standard No. C704-02 for propeller type flowmeters. As with all McCrometer propeller flowmeters, standard features include a magnetically coupled drive, instantaneous flowrate indicator and straight-reading, six-digit totalizer.

Impellers are manufactured of high-impact plastic, capable of retaining their shape and accuracy over the life of the meter. Each impeller is individually calibrated at the factory to accommodate the use of any standard McCrometer register, and since no change gears are used, the MW800 and MM800 can be field-serviced without the need for factory recalibration. Factory lubricated stainless steel bearings are used to support the impeller shaft. The sealed bearing design limits the entry of materials and fluids into the bearing chamber providing maximum bearing protection.

The instantaneous flowrate indicator is standard and available in gallons per minute, cubic feet per second, liters per second and other units. The register is driven by a flexible steel cable encased within a protective vinyl liner. The register housing protects both the register and cable drive system from moisture while allowing clear reading of the flowrate indicator and totalizer.

INSTALLATION

Meter may be mounted in any convenient position compatible with the balance of the system, as long as a full pipeline is assured. Specify direction of flow when ordering. Model MW800 for up flow and model MM800 for down flow.

The Mc Propeller flow meter comes with a standard instantaneous flowrate indicator and straight-reading totalizer. An optional FlowCom register is also available.

Typical face plates.

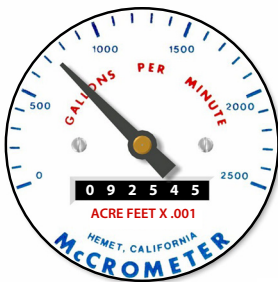

Standard register

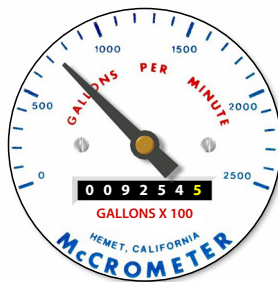

Optional 7-wheel totalizer

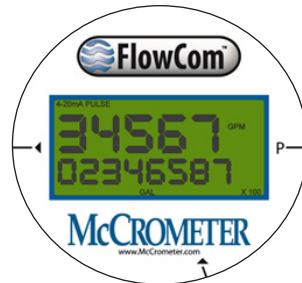

FlowCom register

APPLICATIONS

The McCrometer propeller meter is the most widely used flowmeter for municipal and wastewater treatment applications as well as agricultural and turf irrigation measurement. Typical applications include:

- Water and wastewater management
- Center pivot systems
- Sprinkler irrigation systems
- Drip irrigation systems
- Golf course and park water management
- Gravity turnouts from underground pipelines
- Commercial nurseries

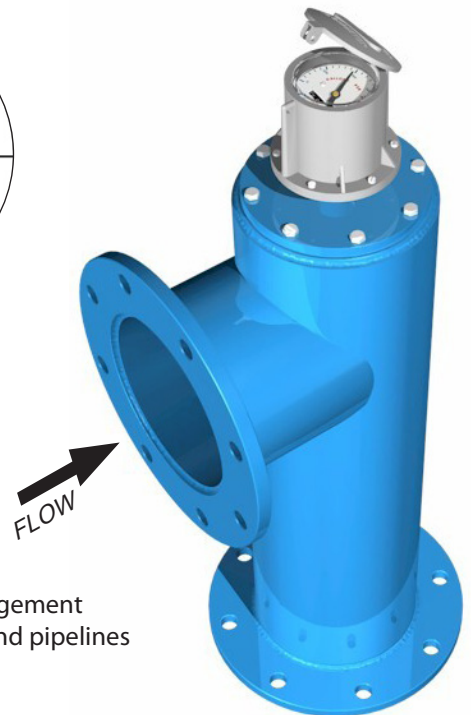

3255 WEST STETSON AVENUE • HEMET, CALIFORNIA 92545 USA

TEL: 951-652-6811 • 800-220-2279 • FAX: 951-652-3078 Printed In The U.S.A. Lit. # 24517-22 Rev. 2.0 / 3-16-18

Copyright © 2001-2017 McCrometer, Inc. All printed material should not be changed or altered without permission of McCrometer. Any published pricing, technical data, and instructions are subject to change without notice. Contact your McCrometer representative for current pricing, technical data, and instructions.



MODEL MW800 / MM800

RIGHT ANGLE FLOWMETER

PERFORMANCE

ACCURACY: ±2% of reading guaranteed throughout range.
RANGE: See dimensions chart below
HEAD LOSS: See dimensions chart below
MAXIMUM TEMPERATURE: (Standard Construction) 160°F constant
PRESSURE RATING: 150 psi. Consult factory for special applications.

MATERIALS

TUBE: Epoxy-coated carbon steel
BEARING ASSEMBLY: Impeller shaft is 316 stainless steel. Ball bearings are 440C stainless steel.
MAGNETS: (Permanent type) Alnico
BEARING HOUSING:
 • For models 2" to 16": 304 stainless steel standard, 316 stainless steel optional
 • For models 18" and larger: Brass standard, 316 stainless steel optional
DROP PIPE: 304 stainless steel
TOP PLATE: Carbon steel
REGISTER: An instantaneous flowrate indicator and six-digit straight-reading totalizer are standard. The register is hermetically sealed within a die cast aluminum case. This protective housing includes a domed acrylic lens and hinged cover with locking hasp.

OPTIONS

- Can be fitted with any flange standard including common international standards
- Forward/reverse flow measurement
- Register extensions available
- High temperature construction
- A complete line of flow recording/control instrumentation
- Certified calibration test results
- Canopy boot

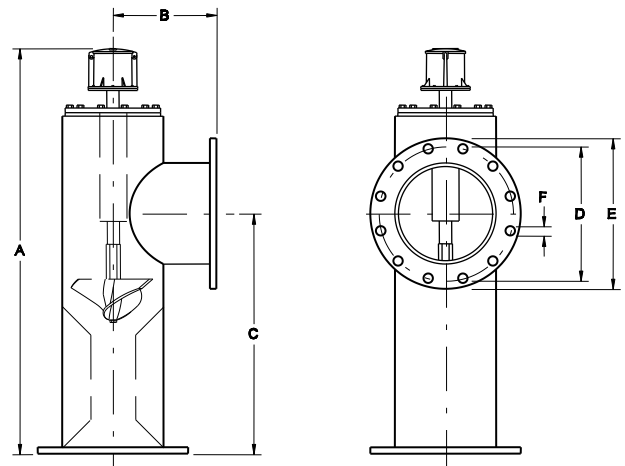

MW800 (UP FLOW) / MM800 (DOWN FLOW)	DIMENSIONS										
Meter and Nominal Pipe Size (inches)	3	4	6	8	10	12	14	16	18	20	24
Maximum Flow U.S. GPM	250	600	1200	1500	1800	2500	3000	4000	5000	6000	8500
Minimum Flow. U.S. GPM	40	50	90	100	125	150	250	275	400	475	700
Approx. Head Loss in Inches at Max. Flow	29.50	23.00	17.00	6.75	3.75	2.75	2.00	1.75	1.50	1.25	1.00
Approx. Shipping Weight- lbs.	50	87	128	182	272	370	519	601	814	976	1293
A (inches)	22 1/2	27 7/8	29 7/8	36 3/8	42 3/8	48 3/8	54	60	66	72 1/2	84 1/2
B (inches)	5	6 1/2	8	9	11	12	14	15	16 1/2	18	22
C (inches)	12 1/4	16 5/8	18	23	28	33	38	43	48	53 1/2	63 1/2
D (inches)	6	7 1/2	9 1/2	11 3/4	14 1/4	17	18 3/4	21 1/4	22 3/4	25	29 1/2
E (inches)	7 1/2	9	11	13 1/2	16	19	21	23 1/2	25	27 1/2	32
F (inches)	3/4	3/4	7/8	7/8	1	1	1 1/8	1 1/8	1 1/4	1 1/4	1 3/8
No. of Bolts per Flange	4	8	8	8	12	12	12	16	16	20	20

Flanges in accordance with A.S.A. B16.5, A.S.T.M. A181 Grade I.
 Contact the factory for MM800 (downflow) meter dimensions.

Larger flowmeters on special order.



3255 WEST STETSON AVENUE • HEMET, CALIFORNIA 92545 USA

TEL: 951-652-6811 • 800-220-2279 • FAX: 951-652-3078 Printed In The U.S.A. Lit. # 24517-22 Rev. 2.0 / 3-16-18

Copyright © 2001-2017 McCrometer, Inc. All printed material should not be changed or altered without permission of McCrometer. Any published pricing, technical data, and instructions are subject to change without notice. Contact your McCrometer representative for current pricing, technical data, and instructions.