

SMBPVA2 Mounting Bracket Kit

Used for mounting Parts Verification Array sensors to 28 mm diameter pipe systems

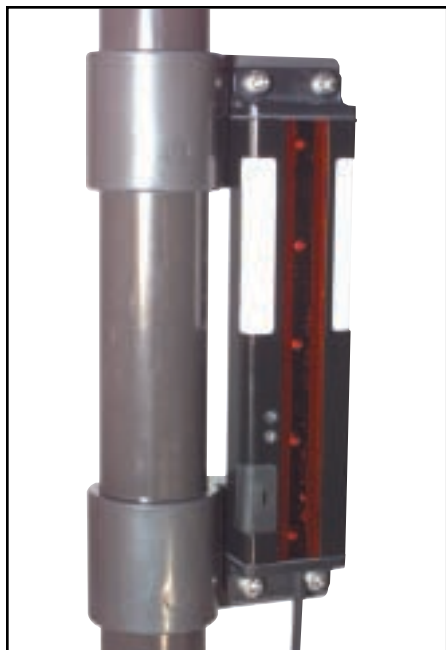

SMBPVA2 Features

- Includes set of four molded brackets for mounting one pair of PVA (Parts Verification Array) sensors
- Brackets easily snap onto standard 28 mm diameter pipe
- PVA sensors mount to the brackets using the M4 hardware supplied with the sensors



Mounting Bracket Dimensions

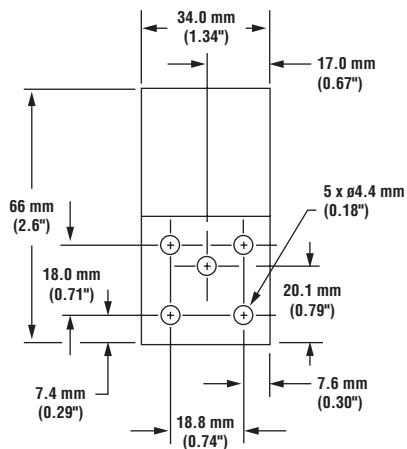

Mounting Orientations

