

Sure Cross® DX80 Gateway for Wireless Q45 Sensors



Datasheet

Configurable DX80 Gateway that uses DIP switches to map inputs from up to six Nodes (or Wireless Q45 Sensors) to the Gateway's outputs



The Sure Cross® wireless system is a radio frequency network with integrated I/O that operates in most environments and eliminates the need for wiring runs. Systems are built around a Gateway, which acts as the wireless network master device, and one or more Wireless Q45 Sensors.

- Wireless industrial I/O device with six discrete (sourcing) inputs and six discrete (sourcing) outputs
- DIP switches allow the user to select one of eight defined I/O mapping configurations to automatically map the Nodes' inputs to this Gateway's outputs
- Frequency Hopping Spread Spectrum (FHSS) technology and Time Division Multiple Access (TDMA) control architecture ensure reliable data delivery within the unlicensed Industrial, Scientific, and Medical (ISM) band
- Transceivers provide bidirectional communication between the Gateway and Node, including fully acknowledged data transmission
- Site Survey analyzes the network's signal strength and reliability and displays the results on the Gateway's LCD
- LCD shows I/O status, Site Survey results, and network status information
- Lost RF links are detected and relevant outputs set to user-defined conditions

For additional information, updated documentation, and accessories, refer to Banner Engineering's website, www.bannerengineering.com/surecross.

Model	Frequency	Environmental Rating	I/O
DX80G2M6-Q	2.4 GHz ISM Band	IP67, NEMA 6	Inputs: Six sourcing discrete Outputs: Six sourcing discrete
DX80G2M6-QC		IP20, NEMA 1	



WARNING: Not To Be Used for Personnel Protection

Never use this device as a sensing device for personnel protection. Doing so could lead to serious injury or death. This device does not include the self-checking redundant circuitry necessary to allow its use in personnel safety applications. A sensor failure or malfunction can cause either an energized or de-energized sensor output condition.

Setting Up and Installing a Wireless Q45

To set up and install your Gateway and Wireless Q45, follow these steps.

1. Configure the Gateway and Wireless Q45 I/O Mapping
2. Wire the Gateway's I/O
3. Apply power to the Gateway
4. Bind the Wireless Q45 to the Gateway
5. Observe the LED behavior to verify the devices are communicating to each other
6. Conduct a Site Survey between the Gateway and the Wireless Q45
7. Install your devices

Configure the Gateway

Configure the DIP Switches

Before making any changes to the DIP switch positions, disconnect the power. DIP switch changes will not be recognized if power isn't cycled to the device.

For parameters not set via DIP switches, use the User Configuration Tool (UCT) to make configuration changes. For parameters set using the DIP switches, the DIP switch positions override any changes made using the User Configuration Tool.



Accessing the Internal DIP Switches

To access the internal DIP switches, follow these steps:

1. Unscrew the four screws that mount the cover to the bottom housing.
2. Remove the cover from the housing without damaging the ribbon cable or the pins the cable plugs into.
3. Gently unplug the ribbon cable from the board mounted into the bottom housing.
4. Remove the black cover plate from the bottom of the device's cover.
The DIP switches are located behind the rotary dials.

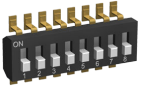

After making the necessary changes to the DIP switches, place the black cover plate back into position and gently push into place. Plug the ribbon cable in after verifying that the blocked hole lines up with the missing pin. Mount the cover back onto the housing.

DIP Switch Settings

At this time, DIP switch 1 is not used.

Modbus/UCT Configured or DIP Switch Configured

In Modbus/UCT Configured mode, the device parameters are changed using the User Configuration Tool (UCT) or a Modbus command. All DIP switch positions are ignored. In DIP Switch Configured mode, use the DIP switches to configure the parameters listed in the table. By default, this Gateway uses the DIP switches to configure the device.

DIP Switch	
2	Modbus/UCT Configured or DIP Switch Configured
OFF *	DIP switch configured
ON	Modbus or UCT configured (DIP switches 3-8 are ignored)

Output State During a Radio Link Loss

The SureCross DX80 wireless devices use a deterministic radio link time-out method to address RF link interruption or failure. When a radio link fails, all pertinent wired outputs are sent to defined states until the link is recovered, ensuring that disruptions in the communications link result in predictable system behavior.

Select the state the outputs are changed to during a link loss.

DIP Switches		
3	4	Output State During a Radio Link Loss
OFF *	OFF *	Off (discrete) or 0 mA (analog)
OFF	ON	On (discrete) or 20 mA (analog)
ON	OFF	Hold last stable state
ON	ON	Reserved

* Default configuration

Heartbeat

In heartbeat mode, the Nodes send "heartbeat" messages to the Gateway at specific intervals to indicate the radio link is active. The heartbeat is always initiated by the Node and is used only to verify radio communications. In this network, the Wireless Q45 Sensors act as Nodes.

DIP Switch	
5	Heartbeat Settings
OFF *	30 seconds (30 to 60 second link loss timeout)
ON	5 seconds (5 to 10 second link loss timeout)

* Default configuration

I/O and Link Loss Alarm Mapping - Wireless Q45 Sensors

The link loss alarm is set to zero (0) when the radio link is working and set to one (1) when the radio link is lost.

Six Wireless Q45 Sensors to one Gateway	DIP Switches		
	6 = OFF*	7 = OFF*	8 = OFF*
	Six Q45 Wireless Sensors: Q45 1 → Gateway OUT 1 Q45 2 → Gateway OUT 2; etc.		

* Default configuration. To use up to 47 Nodes or Wireless Q45 Sensors with this Gateway, you must use a Modbus host controller system. For more information about using a host controller system, refer to the *Host Configuration* manual, Banner document part number 132114.

Three Wireless Q45 Sensors to one Gateway	DIP Switches		
	6 = OFF	7 = OFF	8 = ON
	Three Wireless Q45 Sensors and three link loss: Q45 1 → Gateway OUT 1; Link loss alarm for Q45 1 → Gateway OUT 2 Q45 2 → Gateway OUT 3; Link loss alarm for Q45 2 → Gateway OUT 4 Q45 3 → Gateway OUT 5; Link loss alarm for Q45 3 → Gateway OUT 6		

Three Wireless Q45 Sensors to one Gateway	DIP Switches		
	6 = OFF	7 = ON	8 = OFF
	Three Wireless Q45 Sensors, two inputs each: Q45 1, IN 1 → Gateway OUT 1; Q45 1, IN 2 → Gateway OUT 2 Q45 2, IN 1 → Gateway OUT 3; Q45 2, IN 2 → Gateway OUT 4 Q45 3, IN 1 → Gateway OUT 5; Q45 3, IN 2 → Gateway OUT 6		

Two Wireless Q45 Sensors to one Gateway	DIP Switches		
	6 = OFF	7 = ON	8 = ON
	Two Wireless Q45 Sensors, two inputs each, with link loss: Q45 1, IN 1 → Gateway OUT 1 Q45 1, IN 2 → Gateway OUT 2 Link loss alarm for Q45 1 → Gateway OUT 3 Q45 2, IN 1 → Gateway OUT 4 Q45 2, IN 2 → Gateway OUT 5 Link loss alarm for Q45 2 → Gateway OUT 6		

I/O and Link Loss Mapping - Nodes and Gateways

One Node to one Gateway	DIP Switches		
	6 = ON	7 = OFF	8 = OFF
	<p>One SureCross DX80 Node with 6 inputs and 6 outputs:</p> <p>Node 1, IN 1 → Gateway OUT 1; Gateway IN 1 → Node 1, OUT 1</p> <p>Node 1, IN 2 → Gateway OUT 2; Gateway IN 2 → Node 1, OUT 2</p> <p>Node 1, IN 3 → Gateway OUT 3; Gateway IN 3 → Node 1, OUT 3</p> <p>Node 1, IN 4 → Gateway OUT 4; Gateway IN 4 → Node 1, OUT 4</p> <p>Node 1, IN 5 → Gateway OUT 5; Gateway IN 5 → Node 1, OUT 5</p> <p>Node 1, IN 6 → Gateway OUT 6; Gateway IN 6 → Node 1, OUT 6</p>		

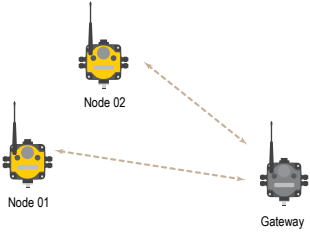
Two Nodes to one Gateway	DIP Switches		
	6 = ON	7 = OFF	8 = ON
	<p>Two SureCross DX80 Nodes, each with 3 inputs and 3 outputs</p> <p>Node 1, IN 1 → Gateway OUT 1; Gateway IN 1 → Node 1, OUT 1</p> <p>Node 1, IN 2 → Gateway OUT 2; Gateway IN 2 → Node 1, OUT 2</p> <p>Node 1, IN 3 → Gateway OUT 3; Gateway IN 3 → Node 1, OUT 3</p> <p>Node 2, IN 1 → Gateway OUT 4; Gateway IN 4 → Node 2, OUT 1</p> <p>Node 2, IN 2 → Gateway OUT 5; Gateway IN 5 → Node 2, OUT 2</p> <p>Node 2, IN 3 → Gateway OUT 6; Gateway IN 6 → Node 2, OUT 3</p>		

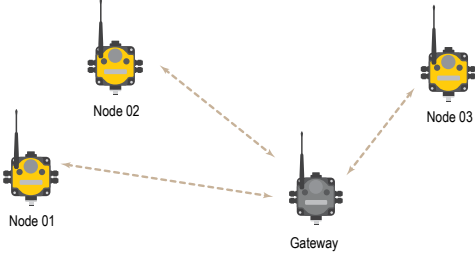
Three Nodes to one Gateway	DIP Switches		
	6 = ON	7 = ON	8 = OFF
	<p>Three SureCross DX80 Nodes, each with 2 inputs and 2 outputs</p> <p>Node 1, IN 1 → Gateway OUT 1; Gateway IN 1 → Node 1, OUT 1</p> <p>Node 1, IN 2 → Gateway OUT 2; Gateway IN 2 → Node 1, OUT 2</p> <p>Node 2, IN 1 → Gateway OUT 3; Gateway IN 3 → Node 2, OUT 1</p> <p>Node 2, IN 2 → Gateway OUT 4; Gateway IN 4 → Node 2, OUT 2</p> <p>Node 3, IN 1 → Gateway OUT 5; Gateway IN 5 → Node 3, OUT 1</p> <p>Node 3, IN 2 → Gateway OUT 6; Gateway IN 6 → Node 3, OUT 2</p>		

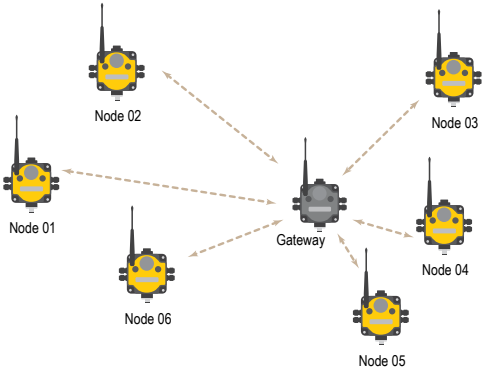
Six Nodes to one Gateway	DIP Switches		
	6 = ON	7 = ON	8 = ON
	<p>Six SureCross DX80 Nodes, each with 1 input and 1 output</p> <p>Node 1, IN 1 → Gateway OUT 1; Gateway IN 1 → Node 1, OUT 1</p> <p>Node 2, IN 1 → Gateway OUT 2; Gateway IN 2 → Node 2, OUT 1</p> <p>Node 3, IN 1 → Gateway OUT 3; Gateway IN 3 → Node 3, OUT 1</p> <p>Node 4, IN 1 → Gateway OUT 4; Gateway IN 4 → Node 4, OUT 1</p> <p>Node 5, IN 1 → Gateway OUT 5; Gateway IN 5 → Node 5, OUT 1</p> <p>Node 6, IN 1 → Gateway OUT 6; Gateway IN 6 → Node 6, OUT 1</p>		

Wire the Gateway's I/O

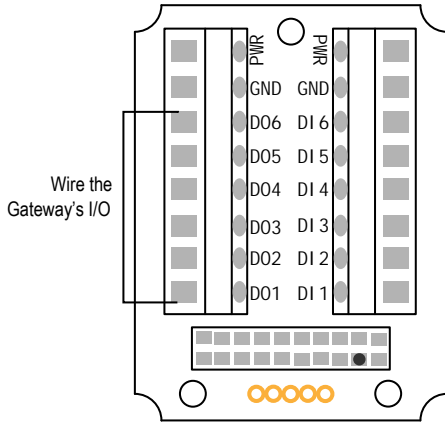

DIx. Discrete IN x
 DOx. Discrete OUT x
 GND. Ground/dc common connection
 PWR. 10 to 30 V dc power connection

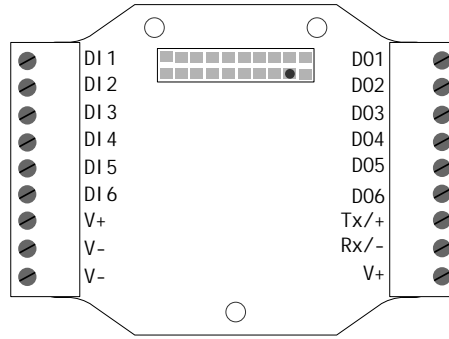

RX/-. Serial communication line for the Gateway. No connection for Nodes
 TX/+. Serial communication line for the Gateway; no connection for Nodes
 V+. 10 to 30 V dc power connection
 V-. Ground/dc common connection

Refer to the Class I Division 2/Zone 2 control drawings (p/n [143086](#)) for wiring specifications or limitations.

Discrete Input Wiring for PNP Sensors

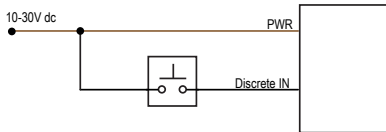

Discrete Output Wiring (PNP)

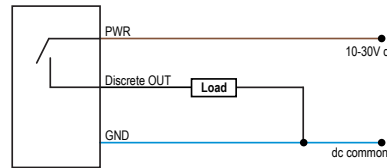

Modbus Register Table for the Gateway with Switch-Based Mapping

I/O	Modbus Holding Register (Gateway)	I/O Type	I/O Range		Holding Register Representation		Terminal Block Labels
			Min.	Max.	Min. (Dec.)	Max. (Dec.)	
1	1	Discrete IN 1	0	1	0	1	DI1
2	2	Discrete IN 2	0	1	0	1	DI2
3	3	Discrete IN 3	0	1	0	1	DI3
4	4	Discrete IN 4	0	1	0	1	DI4
5	5	Discrete IN 5	0	1	0	1	DI5
6	6	Discrete IN 6	0	1	0	1	DI6
7	7	Reserved					
8	8	Device Message					
9	9	Discrete OUT 1	0	1	0	1	DO1
10	10	Discrete OUT 2	0	1	0	1	DO2
11	11	Discrete OUT 3	0	1	0	1	DO3
12	12	Discrete OUT 4	0	1	0	1	DO4
13	13	Discrete OUT 5	0	1	0	1	DO5
14	14	Discrete OUT 6	0	1	0	1	DO6

I/O	Modbus Holding Register (Gateway)	I/O Type	I/O Range		Holding Register Representation		Terminal Block Labels
			Min.	Max.	Min. (Dec.)	Max. (Dec.)	
15	15	Control Message					
16	16	Reserved					

Discrete Bit-Packed Registers

Discrete bit-packed registers include the discrete status registers, discrete inputs, and discrete outputs.

Bit packing involves using a single register, or range of contiguous registers, to represent I/O values.

When networks use similar Nodes to gather data using the same I/O registers for each Node, discrete data from multiple Nodes can be bit packed into a single register on the Gateway. The bit-packed data is arranged by I/O point starting at Modbus register 6601. For example, Discrete IN 1 for all the Nodes in the network is stored in three contiguous 16-bit registers.

The most efficient way to read (or write) discrete data from a SureCross® DX80 Gateway is by using these bit-packed registers because users can read or write registers for all devices using one Modbus message. The following registers contain discrete bit-packed I/O values for the Gateway and all Nodes. Values are stored first for the Gateway, then for each Node in order of Node address.

Bit-Packed Device Status Registers

Register Address	Bit Position															
	15	14	13	12	11	10	9	8	7	6	5	4	3	2	1	0
6601	Node 15	Node 14	Node 13	Node 12	Node 11	Node 10	Node 9	Node 8	Node 7	Node 6	Node 5	Node 4	Node 3	Node 2	Node 1	Gateway
6602	Node 31	Node 30	Node 29	Node 28	Node 27	Node 26	Node 25	Node 24	Node 23	Node 22	Node 21	Node 20	Node 19	Node 18	Node 17	Node 16
6603	Node 47	Node 46	Node 45	Node 44	Node 43	Node 42	Node 41	Node 40	Node 39	Node 38	Node 37	Node 36	Node 35	Node 34	Node 33	Node 32

Bit-Packed Discrete Input 1

Register Address	Bit Position															
	15	14	13	12	11	10	9	8	7	6	5	4	3	2	1	0
6611	Node 15	Node 14	Node 13	Node 12	Node 11	Node 10	Node 9	Node 8	Node 7	Node 6	Node 5	Node 4	Node 3	Node 2	Node 1	Gateway
6612	Node 31	Node 30	Node 29	Node 28	Node 27	Node 26	Node 25	Node 24	Node 23	Node 22	Node 21	Node 20	Node 19	Node 18	Node 17	Node 16
6613	Node 47	Node 46	Node 45	Node 44	Node 43	Node 42	Node 41	Node 40	Node 39	Node 38	Node 37	Node 36	Node 35	Node 34	Node 33	Node 32

Bit-Packed Discrete Output 1

Register Address	Bit Position															
	15	14	13	12	11	10	9	8	7	6	5	4	3	2	1	0
6691	Node 15	Node 14	Node 13	Node 12	Node 11	Node 10	Node 9	Node 8	Node 7	Node 6	Node 5	Node 4	Node 3	Node 2	Node 1	Gateway
6692	Node 31	Node 30	Node 29	Node 28	Node 27	Node 26	Node 25	Node 24	Node 23	Node 22	Node 21	Node 20	Node 19	Node 18	Node 17	Node 16
6693	Node 47	Node 46	Node 45	Node 44	Node 43	Node 42	Node 41	Node 40	Node 39	Node 38	Node 37	Node 36	Node 35	Node 34	Node 33	Node 32

Inputs		Outputs	
Modbus Register Address (Decimal)	Description (Inputs)	Modbus Register Address (Decimal)	Description (Outputs)
6601-6603	Status for all devices		
6611-6613	Input 1 from all devices	6691-6693	Output 1 from all devices
6621-6623	Input 2 from all devices	6701-6703	Output 2 from all devices
6631-6633	Input 3 from all devices	6711-6713	Output 3 from all devices
6641-6643	Input 4 from all devices	6721-6723	Output 4 from all devices
6651-6653	Input 5 from all devices	6731-6733	Output 5 from all devices
6661-6663	Input 6 from all devices	6741-6743	Output 6 from all devices
6671-6673	Input 7 from all devices	6751-6753	Output 7 from all devices
6681-6683	Input 8 from all devices		

Status registers (6601-6603) contain a bit-packed representation defining the devices that are operational in the wireless system.

A one (1) written to the Discrete Status Register area indicates the device is active within the wireless system. A zero (0) indicates the device is not active within the wireless network.

Input registers from all devices use Modbus registers 6611 through 6683 to organize the least significant bit into a sequential array of registers. The first register contains the least significant bit from the input values for the Gateway through Node 15. The second register contains the input values for Node 16 through Node 31, and the third register contains the input values for Nodes 32 through 47.

For discrete inputs, only the least significant bit is used. For analog inputs, the least significant bit indicates if the analog value is above or below the selected threshold value (when using the threshold parameter). For example, a least significant bit of one (1) indicates the analog value is above the selected threshold value. A least significant bit of zero (0) indicates the analog value is below the threshold value.

Output registers from all devices use Modbus registers 6691 through 6753 to organize the least significant bit into a sequential array of registers. Output 8 (I/O point 16) cannot be written using the discrete format.

Apply Power to the Gateway

5-pin M12/Euro-style Wiring for Gateways and DX85s

Wiring the 5-pin Euro-style connector depends on the model and power requirements of the device. Connecting dc power to the communication pins will cause permanent damage.

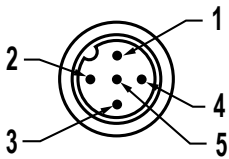
5-pin M12/Euro-style Male Connector	Pin	Wire Color	Description
	1	Brown	10 to 30 V dc
	2	White	RS485 / D1 / B / +
	3	Blue	dc common (GND)
	4	Black	RS485 / D0 / A / -
	5	Gray	Comms Gnd

DX80...C Wiring

Wiring power to the DX80...C models varies depending on the power requirements of the model. Connecting dc power to the communication pins (Tx/Rx) causes permanent damage. For FlexPower devices, do not apply more than 5.5 V to the B+ terminal.

Terminal Label	Gateway and DX85	10 to 30 V dc Powered Nodes	Battery Powered Nodes
V+	10 to 30 V dc	10 to 30 V dc	
Tx/+	RS485 / D1 / B / +		
V-	dc common (GND)	dc common (GND)	dc common (GND)
Rx/-	RS485 / D0 / A / -		
B+			3.6 to 5.5 V dc

Bind the Q45s to the Gateway and Assign the Node Address

Before beginning the binding procedure, apply power to all the devices.

- Enter binding mode on the Gateway.
 - For single-button models, triple-click the button.
 - For two-button models, triple-click button 2.

On the board modules, the green and red LED flashes. On the housed Gateway models, both LEDs flash red.
- Assign the Q45 a Node address using the Gateway's rotary dials. Use the left rotary dial for the left digit and the right rotary dial for the right digit. For example, to assign your Q45 to Node 01, set the left dial to 0 and the right dial to 1. Valid Node addresses are 01 through 47.
- Loosen the clamp plate on the top of the Wireless Q45 Sensor and lift the cover.
- Enter binding mode on the Wireless Q45 Sensor by triple-clicking the button. For the opposed mode sensor, the button is on the receiver.

The red and green LEDs flash alternately and the sensor searches for a Gateway in binding mode. After the Q45 is bound, the LEDs stay solid momentarily, then they flash together four times. The Q45 exits binding mode.
- Label the sensor with the Q45's Node address number and place the sticker on the Wireless Q45 Sensor.
- Repeat steps 2 through 5 for as many Wireless Q45 Sensors as are needed for your network.
- After binding all Wireless Q45 Sensors, exit binding mode on the Gateway.
 - For single-button models, double-click the button.
 - For two-button models, double-click button 2.

For Gateways with LCDs, after binding your Wireless Q45 Sensors to the Gateway, make note of the binding code displayed under the Gateway's *DVCFG menu, XADR submenu on the LCD. Knowing the binding code prevents having to re-bind all Q45s if your Gateway is ever replaced.

Verify Communication Between the Gateway and the Wireless Q45 Sensors

After powering up and binding the Wireless Q45 Sensors to the Gateway, verify all devices are communicating properly. Verify the Gateway's LED 1 is green. Until communication is established with the Gateway, the Q45's red LED flashes. After communication is established, the Q45's green LED flashes.

When testing the Gateway and Wireless Q45 Sensors, verify all radios are at least two meters apart or the communications may fail.

Conducting a Site Survey (Gateway and Nodes)

A Site Survey, also known as a Radio Signal Strength Indication (RSSI), analyzes the radio communications link between the Gateway and any Node within the network by analyzing the radio signal strength of received data packets and reporting the number of missed packets that required a retry.

Perform a Site Survey before permanently installing the radio network to ensure reliable communication. Activate Site Survey mode from either the Gateway buttons or the Gateway Modbus holding register 15. Only the Gateway can initiate a Site Survey, and the Site Survey analyzes the radio communications link with one Node at a time.





Conducting a Site Survey Using the Menu System

Initiate a Site Survey using the Gateway's buttons and menu system.

1. Remove the rotary dial access cover.
2. To check the status of Node 1, change the Gateway's right rotary dial to 1.
The Gateway is now enabled to read the status of Node 1; the display scrolls through the Node's I/O status.
3. Single-click button 1 to scroll across the menu levels until reaching the Site Survey (SITE) menu.
4. Single-click button 2 to enter the Site Survey menu.
5. Single-click button 2 to begin conducting a Site Survey with the Node selected in step 2.
The Gateway analyzes the quality of the signal from the selected Node by counting the number of data packets it receives from the Node.
6. Examine reception readings (M, R, Y, G) of the Gateway at various locations.
Site survey results display as a percentage. M represents the percent of missed packets while R, Y, and G represent the percent of received packets at a given signal strength.
M = Percent of missed packets; R = RED marginal signal; Y = YELLOW good signal; G = GREEN excellent signal.
Record the results if you need troubleshooting assistance from the factory.
7. Change the Gateway's right rotary dial to conduct a Site Survey with another Node and repeat steps 2 through 6.
8. To end the Site Survey, double-click button 2.
9. Change the Gateway's right rotary dial back to 0.
The LCD displays the device readings for the Gateway.
10. Double-click button 2 to move back to the top level menu.
11. Single-click button 1 to return to RUN mode.
12. Install the rotary dial access cover, referring to the Installation section of the manual to create an IP67 seal.

Interpreting the Site Survey Results

Site Survey results are listed as a percentage of data packets received and indicate the signal strength of the received signal.

	Result	Description
	Green	Packets received at a strong signal strength. A strong signal strength is greater than -90 dBm at the receiver.
	Yellow	Packets received at a good signal strength. A good signal is between -90 and -100 dBm at the receiver.
	Red	Packets received at a weak signal strength. A weak signal is less than -100 dBm at the receiver.
	Missed	Packets not received on the first transmission and requiring a retry.

Judging if the reliability of a network's signal meets the needs of the application is not just a matter of green, yellow, and red packets received. In normal operating mode, when data packets are not received, the transmitter re-sends the packet until all data is received.



For slow monitoring applications such as a tank farm, where data is required in terms of seconds or minutes, receiving most of the data in the 'red' range, indicating a weak but reliable signal, transmits enough data for accurate monitoring. Nodes positioned near the outside range of the radio signal may have 90% of the data packets received in the red zone, again indicating a weak, but reliable signal.

We recommend keeping the missed packets average to less than 40%. When the network misses more than 40% of the data packets, the signal is usually too unreliable or obstacles may be interfering with the signal. When Site Survey reports the missed packets are 40% or higher, improve the radio system performance by:

- Mounting the network's antennas higher,
- Using higher gain antennas, or
- Adding data radios to the network.

Mounting the devices' antennas higher allows the radio signal to clear obstacles in the area and improves the line of sight between SureCross® devices. Higher gain antennas focus the energy of the radio signal in a specific direction and extend the signal's range. Using data radios is another option to consider when trying to extend the range of a radio network. For more information on data radios, please refer to Banner's white paper on range extension on www.bannerengineering.com/surecross.

Specifications

Radio Range 2.4 GHz, 65 mW: Up to 3.2 km (2 miles) ¹	Supply Voltage ² 10 to 30 V dc (Outside the USA: 12 to 24 V dc, ±10%). Consumption: Less than 1.4 W (60 mA) at 24 V dc
Minimum Separation Distance 2.4 GHz, 65 mW: 0.3 m (1 ft)	Housing Polycarbonate housing and rotary dial cover; polyester labels; EDPM rubber cover gasket; nitrile rubber, non-sulphur cured button covers Weight: 0.26 kg (0.57 lbs) Mounting: #10 or M5 (SS M5 hardware included) Max. Tightening Torque: 0.56 N·m (5 lbf·in)
Transmit Power 2.4 GHz, 65 mW: 18 dBm (65 mW) conducted, less than or equal to 20 dBm (100 mW) EIRP	Antenna Connection Ext. Reverse Polarity SMA, 50 Ohms Max Tightening Torque: 0.45 N·m (4 lbf·in)
2.4 GHz Compliance FCC ID UE300DX80-2400 - This device complies with FCC Part 15, Subpart C, 15.247 ETSI EN 300 328 V1.8.1 (2012-06) IC: 7044A-DX8024	Interface Indicators: Red/Green Power LED, Red/Yellow Signal LED
Spread Spectrum Technology FHSS (Frequency Hopping Spread Spectrum)	Wiring Access Two 1/2-inch NPT
Discrete Inputs Rating: 3 mA max current at 30 V dc Sample Rate: 62.5 milliseconds Report Rate: On change of state ON Condition (PNP): Greater than 8 V OFF Condition (PNP): Less than 5 V	Discrete Outputs Update Rate: 125 milliseconds ON Condition: Supply minus 2 V OFF Condition: Less than 2 V Output State Following Timeout: OFF
Communication Hardware (RS-485) Interface: 2-wire half-duplex RS-485 Baud rates: 9.6k, 19.2k (default), or 38.4k Data format: 8 data bits, no parity, 1 stop bit	Discrete Output Rating (PNP) 100 mA max current at 30 V dc ON-State Saturation: Less than 3 V at 100 mA OFF-state Leakage: Less than 10 µA
Communication Protocol Modbus RTU	Certifications   CSA: Class I Division 2 Groups ABCD, Class I Zone 2 AEx/Ex nA II T4 — Certificate: 1921239  ATEX: II 3 G Ex nA IIC T4 Gc (Group IIC Zone 2) — Certificate LCIE 10 ATEX 1012 X
Environmental Rating IEC IP67; NEMA 6	Refer to the Class I Division 2/Zone 2 control drawings (p/n 143086) for wiring specifications or limitations. All battery-powered devices must only use the lithium battery manufactured by Xeno, model XL-205F.
Operating Conditions ³ -40 °C to +85 °C (-40 °F to +185 °F) 95% maximum relative humidity (non-condensing) Radiated Immunity: 10 V/m (EN 61000-4-3)	
Shock and Vibration IEC 68-2-6 and IEC 68-2-27 Shock: 30g, 11 millisecond half sine wave, 18 shocks Vibration: 0.5 mm p-p, 10 to 60 Hz	

¹ Radio range is with the 2 dB antenna that ships with the product. High-gain antennas are available, but the range depends on the environment and line of sight. Always verify your wireless network's range by performing a Site Survey.

² For European applications, power this device from a Limited Power Source as defined in EN 60950-1.

³ Operating the devices at the maximum operating conditions for extended periods can shorten the life of the device.

Warnings

Install and properly ground a qualified surge suppressor when installing a remote antenna system. Remote antenna configurations installed without surge suppressors invalidate the manufacturer's warranty. Keep the ground wire as short as possible and make all ground connections to a single-point ground system to ensure no ground loops are created. No surge suppressor can absorb all lightning strikes; do not touch the Sure Cross® device or any equipment connected to the Sure Cross device during a thunderstorm.

Exporting Sure Cross® Radios. It is our intent to fully comply with all national and regional regulations regarding radio frequency emissions. Customers who want to re-export this product to a country other than that to which it was sold must ensure the device is approved in the destination country. A list of approved countries appears in the *Radio Certifications* section of the product manual. The Sure Cross wireless products were certified for use in these countries using the antenna that ships with the product. When using other antennas, verify you are not exceeding the transmit power levels allowed by local governing agencies. Consult with Banner Engineering Corp. if the destination country is not on this list.

Any misuse, abuse, or improper application or installation of this product or use of the product for personal protection applications when the product is identified as not intended for such purposes will void the product warranty. Any modifications to this product without prior express approval by Banner Engineering Corp will void the product warranties. All specifications published in this document are subject to change; Banner reserves the right to modify product specifications or update documentation at any time. For the most recent version of any documentation, refer to: www.bannerengineering.com. © Banner Engineering Corp. All rights reserved.

Banner Engineering Corp. Limited Warranty

Banner Engineering Corp. warrants its products to be free from defects in material and workmanship for one year following the date of shipment. Banner Engineering Corp. will repair or replace, free of charge, any product of its manufacture which, at the time it is returned to the factory, is found to have been defective during the warranty period. This warranty does not cover damage or liability for misuse, abuse, or the improper application or installation of the Banner product.

THIS LIMITED WARRANTY IS EXCLUSIVE AND IN LIEU OF ALL OTHER WARRANTIES WHETHER EXPRESS OR IMPLIED (INCLUDING, WITHOUT LIMITATION, ANY WARRANTY OF MERCHANTABILITY OR FITNESS FOR A PARTICULAR PURPOSE), AND WHETHER ARISING UNDER COURSE OF PERFORMANCE, COURSE OF DEALING OR TRADE USAGE.

This Warranty is exclusive and limited to repair or, at the discretion of Banner Engineering Corp., replacement. IN NO EVENT SHALL BANNER ENGINEERING CORP. BE LIABLE TO BUYER OR ANY OTHER PERSON OR ENTITY FOR ANY EXTRA COSTS, EXPENSES, LOSSES, LOSS OF PROFITS, OR ANY INCIDENTAL, CONSEQUENTIAL OR SPECIAL DAMAGES RESULTING FROM ANY PRODUCT DEFECT OR FROM THE USE OR INABILITY TO USE THE PRODUCT, WHETHER ARISING IN CONTRACT OR WARRANTY, STATUTE, TORT, STRICT LIABILITY, NEGLIGENCE, OR OTHERWISE.

Banner Engineering Corp. reserves the right to change, modify or improve the design of the product without assuming any obligations or liabilities relating to any product previously manufactured by Banner Engineering Corp.