

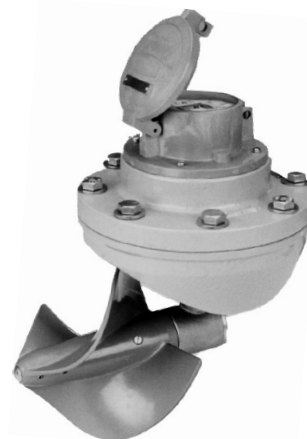

MODEL ML19
 150 psi WELDING SADDLE METER
 SEALED METER MECHANISM - MAGNETIC DRIVE
 SEALED TOTALIZER
 SIZES 4" thru 72"



TOTALIZER



DESCRIPTION

MODEL ML19 WELDING SADDLE METERS are manufactured to the highest standards. Materials used on all meters and flow ranges for the low velocity meter meet or exceed AWWA standard C704-02. The weld-on design permits use in a wide range of applications with up to 150 psi working pressure. It is necessary, upon ordering, to furnish the I.D. dimension of the pipe the meter is to be mounted on for calibration purposes. The O.D. dimension or wall thickness must also be furnished for proper fit of the saddle to the pipe.

INSTALLATION is made by cutting a hole in the existing pipe line and then welding the saddle to the line. The removable meter head assembly can then be bolted to the saddle. The meter can be installed in any of the following positions; vertically, horizontally or inclined on suction or discharge lines. The meter must have a full flow of liquid for proper accuracy. Fully opened gate valves, fittings or other obstructions that tend to set up flow disturbances should be a minimum of ten pipe diameters upstream and two pipe diameters downstream from the meter. Installations with less than ten pipe diameters of straight pipe require straightening vanes. Meters with straightening vanes require five pipe diameters upstream and two pipe diameters downstream.

PROPELLER is magnetically coupled with the drive mechanism through the sealed oil filled gearbox. This completely eliminates water entering the meter assembly, as well as the need for any packing gland. The propeller is a conical shaped three bladed propeller, injection molded of thermoplastic material resistant to normal water corrosion and deformity due to high flow velocities.

BEARING in 4" thru 54" propellers is a water lubricated ceramic sleeve and spindle bearing system with a ceramic/stainless steel spindle. Dual ceramic thrust bearings, standard on all 4" - 54" meters, handle flows in both forward and reverse directions. The 60" thru 72" propeller bearings are sealed stainless steel ball bearings that ride on a stainless steel spindle. The bearing design promotes extended periods of maintenance free propeller operation. Bearings within the sealed meter mechanism are shielded precision stainless steel bearings and are factory lubricated for the life of the meter.

TOTALIZER is o-ring sealed and magnetically coupled with the driving mechanism, and features a six digit totalizer with a full 3" diameter, 100 division, center sweep dial that permits extremely accurate readings for timing purposes in determining flow rates. The totalizer dial can be furnished in gallons, cubic feet, acre feet, or any standard liquid measuring units. The bonnet, with padlock hasp, can be positioned in four different directions for the easiest possible reading when the meters are mounted in unusual positions.

CHANGE GEARS may be easily exchanged in the field when changing the dial, or when recalibrating for different pipe sizes. It is not necessary to remove pressure from the line for these changes.

O-RING SEALS are used at the meter head and all points where seals are required, making the meter mechanism completely immune to any of the corrosive effects of atmospheric moisture or liquids.

SPECIFICATIONS

- ACCURACY** Plus or minus 2% of actual flow within the range specified for each meter size.
- PRESSURE RANGE** Up to 150 PSI maximum working pressure.
- TEMPERATURE RANGE** 140° F Maximum. Consult factory for special construction for higher temperatures.
- MINIMUM FLOWS** As shown for each meter size and construction are required for accurate registration. See flow chart.
NOTE: Minimum flow will be higher when auxiliary equipment is added.
- MAXIMUM FLOWS** As shown for each meter size and construction are rated for continuous operation. See flow chart.
- INTERMITTENT FLOWS** As shown for each meter size are rated for 10% to 15% of the total time the meter is operating. Consult factory for High Velocity construction when intermittent flows are higher than shown on flow chart and/or when longer operating periods are required.
- MATERIALS** Used in construction are chosen to minimize the corrosive effects of the liquids measured by the meter assembly.
MAGNETS - permanent ceramic type
INTERIOR BEARINGS - shielded stainless steel
PROPELLER BEARING - ceramic sleeve type (4"-54") or sealed stainless steel ball type (60"-72")
PROPELLER SPINDLE - ceramic sleeve/stainless steel (4"-54") or stainless steel (60"-72")
PROPELLER - injection molded thermoplastic
GEARBOX - stainless steel (4"-54")
SEPARATOR - stainless steel
SHAFTS - stainless steel
METER HEAD BOLTS - stainless steel (4"-20"), plated steel (24"-72")
METER HEAD - cast iron or fabricated steel, NSF approved fusion epoxy coated.
- OPTIONAL EQUIPMENT** Totalizer Extensions and a wide range of controls and instruments for indicating, totalizing and recording flow data for each meter. Special constructions and materials are available upon request.
- ORDERING INFO** Must be specified by the customer and includes:
Minimum & maximum flow ranges
Temperature of meter environment
Totalizer dial units
Type of materials and construction
Optional equipment desired
Pipe I.D. and O.D.

MODEL ML19
 150 psi WELDING SADDLE METER
 SEALED METER MECHANISM-MAGNETIC DRIVE
 SEALED TOTALIZER
 SIZES 4" thru 72"

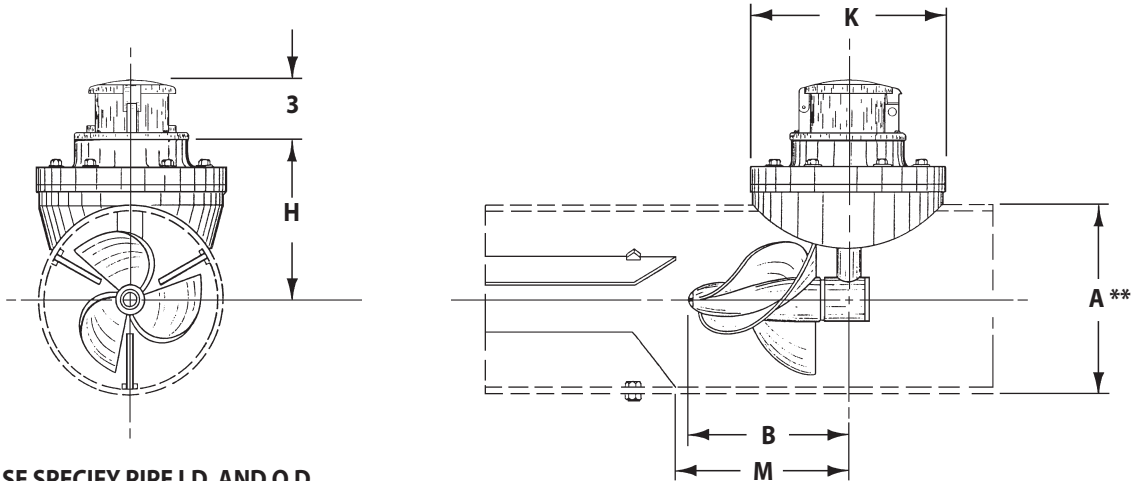

**** PLEASE SPECIFY PIPE I.D. AND O.D.**

METER & PIPE SIZE	FLOW RANGES, GPM		DIMENSIONS					EST. SHIPPING WEIGHT POUNDS
	STANDARD CONSTRUCTION MIN. - MAX. - INT.	HIGH VELOCITY CONSTRUCTION MIN. - MAX.	A	B	H	K	M	
4	55-500-700	200-700	4 1/2	8	5 3/16	9	10	55
6	120-1200-1500	300-1500	6 5/8	8	6 1/4	9	10	55
8	150-1500-2000	400-2500	8 5/8	8	7 1/4	9	10	55
10	180-2000-3000	500-3500	10 3/4	8	8 1/2	11	10	60
12	200-3000-3500	800-5000	12 3/4	8	9 1/2	11	10	70
14	300-4000-4500	1000-6000	14	8	10 1/2	13 1/2	10	75
16	400-5000-6000	1200-7500	16	8	11 1/2	13 1/2	10	75
18	700-6000-7500	1500-9000	18	8	12 1/2	13 1/2	10	75
20	850-8000-9000	2000-12000	20	8	13 1/2	13 1/2	10	75
24	1000-10000-13500	3000-15000	24	11 1/2	17 1/2	21	13 1/2	250
30	1800-15000-21000	4000-25000	30	11 1/2	20 1/2	21	13 1/2	250
36	2000-20000-30000	5000-35000	36	11 1/2	23 1/2	21	13 1/2	250
42	3000-30000-40000	6000-50000	42	11 1/2	27	32	13 1/2	525
48	5500-35000-50000	7000-60000	48	11 1/2	30	32	13 1/2	525
54	6500-45000-55000	8000-65000	54	11 1/2	33	32	13 1/2	525
60	7500-60000-80000	10000-90000	60	18 [‡]	36	32	22 [‡]	525
66	8500-75000-95000	12000-105000	66	18 [‡]	39	32	22 [‡]	525
72	9500-90000-115000	15000-125000	72	18 [‡]	42	32	22 [‡]	525

Standard construction will be supplied for all main line meters unless special flow range, materials, or construction are required.

* Low velocity (LV) construction has the same low and maximum flow rates as AWWA C704.

‡ On High Velocity Meters "B" Dimension is 11 1/2" and "M" dimension is 13 1/2".



www.mccrometer.com

3255 WEST STETSON AVENUE • HEMET, CALIFORNIA 92545 USA
 TEL: 951-652-6811 • FAX: 951-652-3078

Copyright © 2002-2013 McCrometer. All printed material should not be changed or altered without permission of McCrometer. The published technical data and instructions are subject to change without notice. Contact your McCrometer representative for current technical data and instructions.