



Series BAT

BLIND ANALOG TRANSMITTER INSTRUCTIONS



GENERAL INFORMATION

The Dwyer Instruments Inc. Series BAT is a blind (non-indicating) 4 to 20 mA transmitter, designed for use with Series EFS2, IEFS, PDWS, TBS and FLMG flow sensors. It accepts a pulse frequency input from the flow sensor, and converts this input into a continuous analog output signal. Power for the transmitter is taken from the current loop itself, so only two wires are required. The digital design makes it possible to span the unit in the field without tools. The frequency at which 20 mA is desired is entered on a set of rotary switches, and an internal microcontroller automatically scales all other values accordingly. An additional benefit of the microcontroller is its ability to average inputs, for smoothing of the output signal. The degree of averaging can be selected in the field, from 2 to 16 seconds.

For maximum environmental protection, the electronic components are encased in a special semi-flexible urethane potting material. The housing is cast from aluminum and fuse-coated. The clamshell housing offered in the BAT-M is connected directly to the flow sensor or, in the wall mount version, BAT-W, provided with mounting feet.

The BAT will operate on a relatively wide range of current loop voltages, 24 to 36 Vdc. Lower voltages limit the load that can be applied to the loop without distortion of the signal. (See Load/Supply chart if there is a question regarding voltage vs. load.) A built-in power regulator supplies the appropriate power to the flow sensor.

Typical applications for this transmitter are telemetry (or SCADA), distributed control systems, programmable controllers,

SPECIFICATIONS*

Power	24 to 36 Vdc	
Temperature	32 to 130° F (0 to 55° C)	
Input	Open-collector solid state sensor	
Input Averaging	2 to 16 seconds (switch selectable)	
Response Time	2 to 60 seconds; 90% of full-scale (dependent on input averaging)	
Frequency	Minimum	10 Hz (@20 mA)
	Maximum	999.9 Hz
	Setting	4 Rotary DIP switches
Output	Proportional 4 to 20 mA	

*Specifications subject to change

INSTALLATION

Mounting. The BAT-M can be mounted on the flow sensor. The BAT-W wall mount comes with mounting feet and requires four screws to attach it to any stable surface.

Connection. On either style of housing, the upper portion must be removed to make connections. Use a standard hex wrench (5/32" or 4 mm) to loosen the screws, then remove the upper half. The connections are made to terminal blocks in the upper half, which contains the potted electronics.

Consult the Connections diagram before connecting to the current loop. The only connections required on a BAT-M are the positive and negative loop connections. On a BAT-W, the sensor must also be connected, since it is remote from the transmitter. Be careful to follow the color coding of the flow sensor wires in order to establish the correct polarity. Incorrect polarity can damage the sensor.

WARRANTY/RETURN

Refer to "Terms and Conditions of Sale" in our catalog or on our website. Contact customer service to receive a Returns Goods Authorization number before shipping your product back for repair. Be sure to include a brief description of the problem plus any relevant application notes.

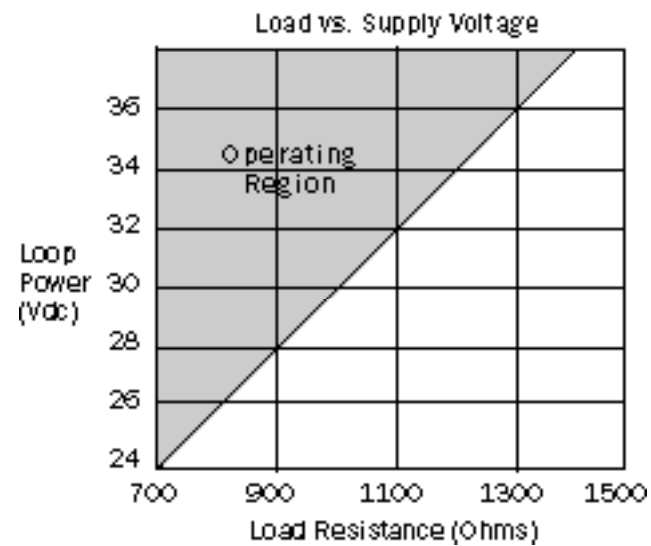

SETTINGS

Setting Frequency. The BAT converts a train of off/on pulses from the flow sensor into a continuous mA signal that ranges from 4 mA at zero flow to 20 mA at the desired maximum flow. The desired maximum is determined by the user and entered as a frequency as follows:

- 1) Decide what flow rate should represent the top of the scale. This is ordinarily the maximum expected flow, or a value just above it, in gallons per minute.
- 2) Locate the K-factor of the flow sensor (found on the meter or fitting, or in the instruction manual, depending on meter model). The K-factor is the number of pulses the flow sensor produces per gallon of flow.
- 3) Calculate frequency, using this formula:
$$\text{K-Factor} \times \frac{\text{Top Flow (GPM)}}{60} = \text{Frequency}$$
- 4) Enter the frequency using the four rotary Frequency switches. Note the decimal point between the third and fourth switches.

SETTING FREQUENCY EXAMPLE

- 1) In an installation with an estimated maximum flow rate of about 150 GPM, a flow rate of 170 GPM is selected as the full-scale maximum, the flow at which the current loop will register 20 mA.
- 2) In this example, the K-factor (found on the meter or fitting, or in the manual) is "K = 54.50".
- 3) Calculate the frequency as
$$54.50 \times \frac{170}{60} = 154.42$$
- 4) Rounding to one decimal point, enter 154.4 on the rotary switches by turning the rotary switch pointers to the desired digits.

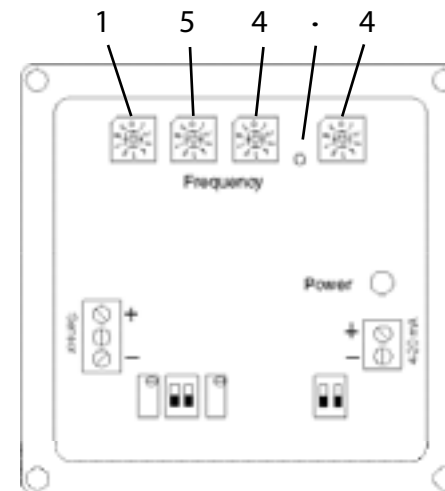

Setting Averaging Time. For most applications this step can be ignored, as the standard setting will work fine. However, when a particularly steady output signal is desired, or in a large pipe, a larger averaging period may be desirable. Note however that the averaging period requires a tradeoff, since a longer averaging period implies a slower response time. If steady signal is more important than fast response, increase the averaging time as desired. See the diagram below for the switch positions and their corresponding times.

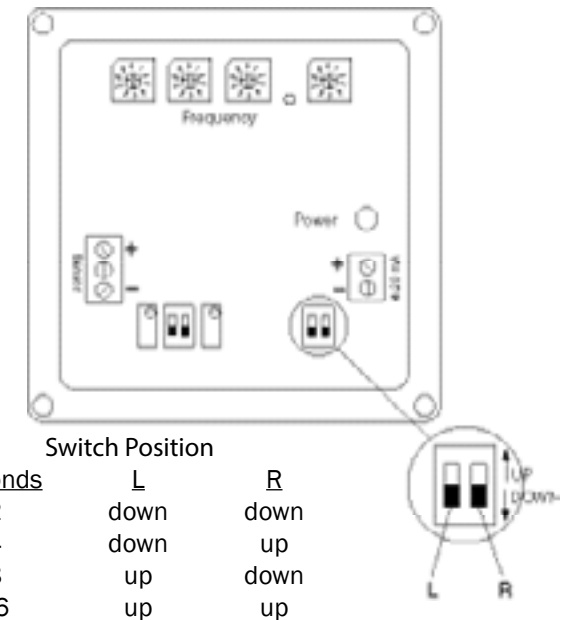

Checking Calibration

Normally it should not be necessary to check calibration, since the digital design of this unit virtually eliminates drift. However, there are two types of calibration check that can be performed. Look at the diagram below to locate the 4 and 20 mA force switches. To force the 4 mA output, put its switch in the up position. Check the current output at the Power terminals, and if necessary, trim to 4.00 mA using the appropriate trimpot. Return the switch to the down position, and repeat the process with the 20 mA switch and appropriate trimpot.

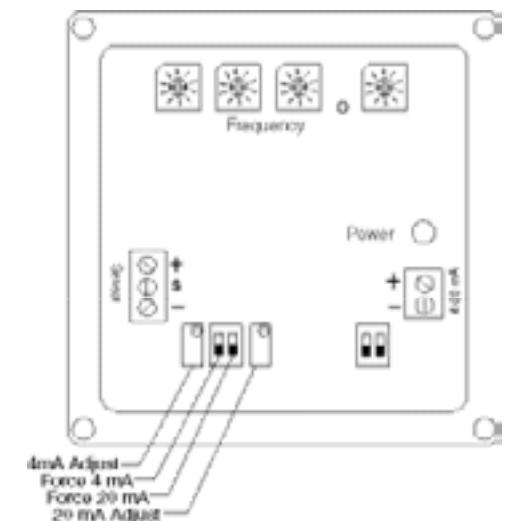

CONNECTIONS

The Series BAT can be wired to either a mechanical meter or an electromagnetic flow meter. See alternative configurations below.

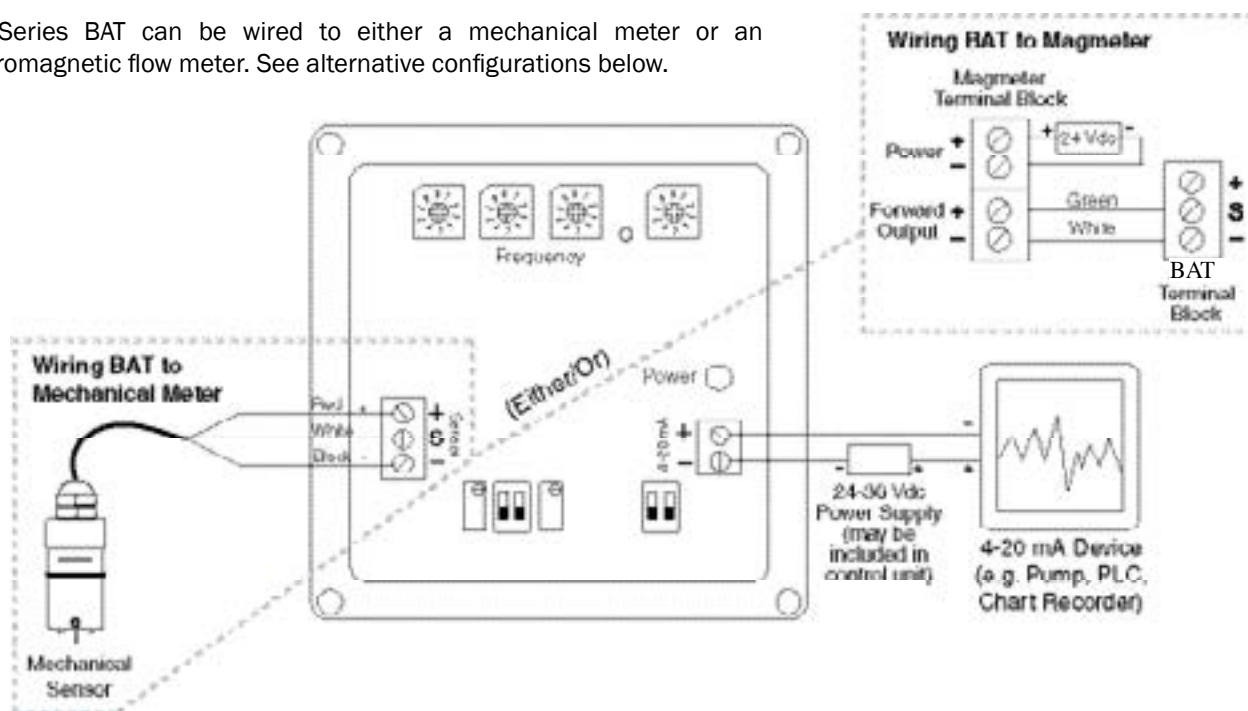

TROUBLESHOOTING

Problem	Probable Cause	Try...
No analog signal at reading device	Break in current loop Dead power supply Reversed polarity	Check if loop indicator light is on Check multimeter voltage on power supply Check polarity
Output stuck at 4 mA	No frequency input from flow sensor	Check if flow sensor rotor is turning freely (mechanical meters only) Check flow sensor connections Check flow sensor polarity Be sure terminal blocks are firmly plugged in With flow sensor disconnected, use short wire to repeatedly short between sensor "sig" and "-" terminals. Output should rise. Verify 3-second pulse output (Series EFS2 and IEFS meters only)
mA signal does not match flow rate	Inadequate voltage Wrong frequency setting	Check load vs. supply chart Review setting procedure Check multimeter voltage on power supply

