



DeZURIK DOUBLE-ACTING HYDRAULIC CYLINDER FOR G-SERIES ACTUATORS

Instruction **D10023**
August 2012

DeZURIK

Double-Acting Hydraulic Cylinder for G-Series Actuators

Instructions

These instructions provide information about hydraulic cylinders. They are for use by personnel who are responsible for installation, operation and maintenance of hydraulic cylinders.

Safety Messages

All safety messages in the instructions are flagged with an exclamation symbol and the word Caution, Warning or Danger. These messages indicate procedures that must be followed exactly to avoid equipment damage, personal injury or death.

Safety label(s) on the product indicate hazards that can cause equipment damage, personal injury or death. If a safety label becomes difficult to see or read, or if a label has been removed, please contact DeZURIK for replacement label(s).



WARNING!

Personnel involved in the installation or maintenance of valves should be constantly alert to potential emission of pipeline material and take appropriate safety precautions. Always wear suitable protection when dealing with hazardous pipeline materials. Handle valves, which have been removed from service with suitable protection for any potential pipeline material in the valve.

Inspection

Your hydraulic cylinder has been packaged to provide protection during shipment; however, it can be damaged in transport. Carefully inspect the unit for damage upon arrival and file a claim with the carrier if damage is apparent.

Parts

Recommended spare parts are listed on the assembly drawing. These parts should be stocked to minimize downtime.

Order parts from your DeZURIK sales representative, or directly from DeZURIK. When ordering parts, please include the 7-digit part number and 4-digit revision number (example: **9999999R000**) located on the data plate attached to the valve assembly. Also include the part name, the assembly drawing number, the balloon number and the quantity stated on the assembly drawing.

DeZURIK Service

DeZURIK service personnel are available to install, maintain and repair all DeZURIK products. DeZURIK also offers customized training programs and consultation services.

For more information, contact your local DeZURIK sales representative or visit our website at www.dezurik.com.

Table of Contents

| | |
|--------------------------------------|---|
| Description - - - - - | 4 |
| Supply - - - - - | 4 |
| Lubrication - - - - - | 4 |
| Closed Position Adjustment - - - - - | 4 |
| Disassembly - - - - - | 4 |
| Reassembly - - - - - | 5 |

DeZURIK

Double-Acting Hydraulic Cylinder for G-Series Actuators

Description

This instruction covers the double-acting hydraulic cylinder used on G-Series actuators. This cylinder can be used with Pumpcheck accessories.



CAUTION!

This cylinder is a pressure-containing vessel. Release the pressure from both ends of the cylinder before attempting any disassembly or repairs.

Supply

Supply medium is clean water. Minimum supply pressure is 50 psi. Maximum supply pressure is 150 psi.

Lubrication

When the cylinder is disassembled, lubricate the grooves in the piston, the piston seal, the O-rings, and the cylinder wall using one of these lubricants.

- Dow Corning Molykote No. 44 (**recommended**)
- Shell Retinax AM (alternate)
- Shell Lithall MDS (alternate)

Closed Position Adjustment

1. Turn the setscrew in the end of the cylinder counterclockwise approximately 5 revolutions.
2. Close the valve. See the valve instruction sheet to determine closed position.
3. Turn the setscrew clockwise until resistance is felt as it contacts the piston rod.
4. Lock in place with the nut, being sure the thread seal is positioned properly.

Disassembly

1. Shut off the cylinder supply pressure and relieve the pressure in the cylinder.
2. If the actuator is powered, disconnect and lock out the pneumatic, hydraulic, or electrical power to prevent accidental operation of the actuator.



WARNING!

Moving parts from accidental operation of power actuator can cause personal injury or equipment damage. Disconnect and lock out power to actuator before servicing.

3. Disconnect the cylinder tubing.

Disassembly (continued)

4. Remove the nuts and washers from the cylinder cap end of the tie rods and remove the cylinder cap.
5. Remove the cylinder tube. Rotate it while pulling it off the piston.
6. Remove the nut fastening the piston to the piston rod and remove the piston.
7. Remove the nuts from the cylinder head end of the tie rods and remove the cylinder head.
8. Remove the gland and packing from the cylinder head.
9. Remove the two scrapers. One scraper is found in the cylinder head, the other is in the gland. Figure 1 shows their location.

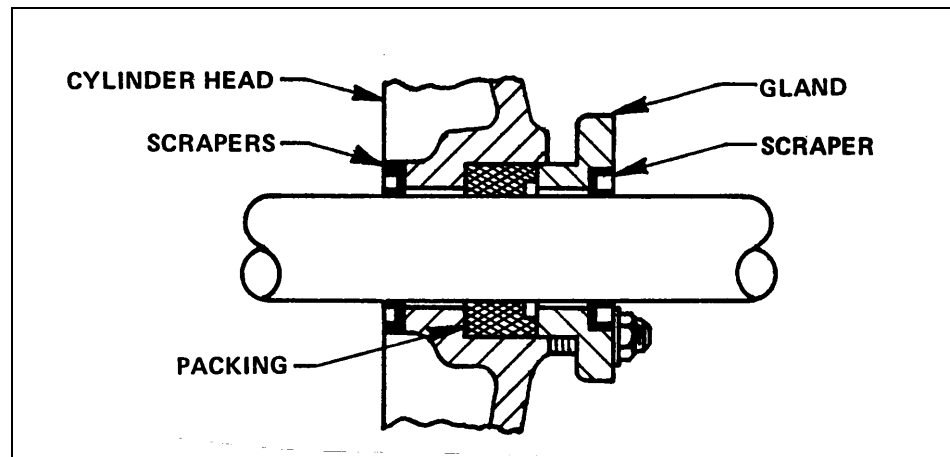

Figure 1 – Scraper Locations

Reassembly

1. Clean and examine the rod scrapers. If they are damaged, use new scrapers. Install the scrapers in the cylinder head and the gland.
2. Clean the packing chamber and the O-ring groove in the cylinder head. Then assemble the gland and the cylinder head on the piston rod.
3. Install the packing. It is recommended that new packing be used.
4. Place the lubricated O-ring in the cylinder head.
5. Remove the O-ring from the center of the piston and clean the O-ring groove. Inspect the O-ring, replacing it if damaged, and install the lubricated O-ring.
6. Slide the piston onto the piston rod, and install and tighten the nut.
7. Remove the piston seal and its O-ring and clean the O-ring, seal and the groove in the piston. Inspect the O-ring and seals, replacing them if damaged. Then install the lubricated O-ring and seal.
8. Lubricate the inside of the cylinder tube and slide the cylinder over the piston. On cylinders with 6" and larger diameter, start the cylinder at a 45 angle to the piston as shown in Figure 2. (It will be necessary to remove several cylinder tie rods to provide clearance.)

DeZURIK

Double-Acting Hydraulic Cylinder for G-Series Actuators

Reassembly (continued)

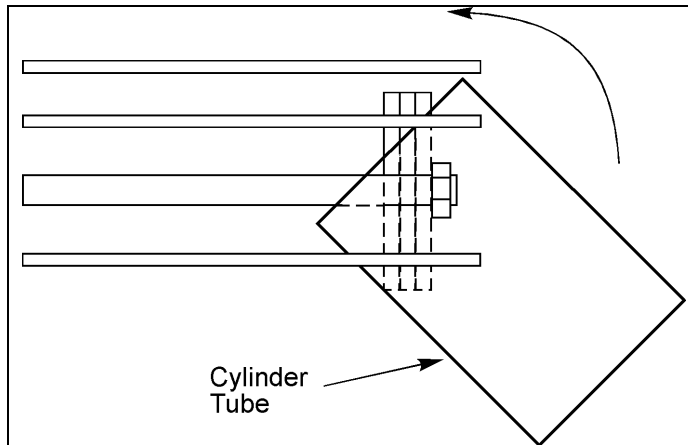

Figure 2 – Cylinder Tube Installation

9. Clean the O-ring groove in the cylinder cap and install the lubricated O-ring.
10. Install the cylinder cap, lock washers and nuts. Tighten the nuts on the tie rods with the torques specified in Table A.

Table A: Tie Rod Nut Torque

| Cylinder Size | Torque | | |
|---------------|----------|---------|------|
| | (ft lbs) | (cm/kg) | (Nm) |
| 3" & 4" | 12 | 165 | 16 |
| 6" & 8" | 16 | 220 | 22 |
| 10" & 12" | 20 | 275 | 27 |

11. Reconnect the tubing to the cylinder ports.
12. If the actuator is a powered actuator, reconnect power to the actuator.
13. Actuate the cylinder, checking the closed position adjustment.

Reassembly (continued)

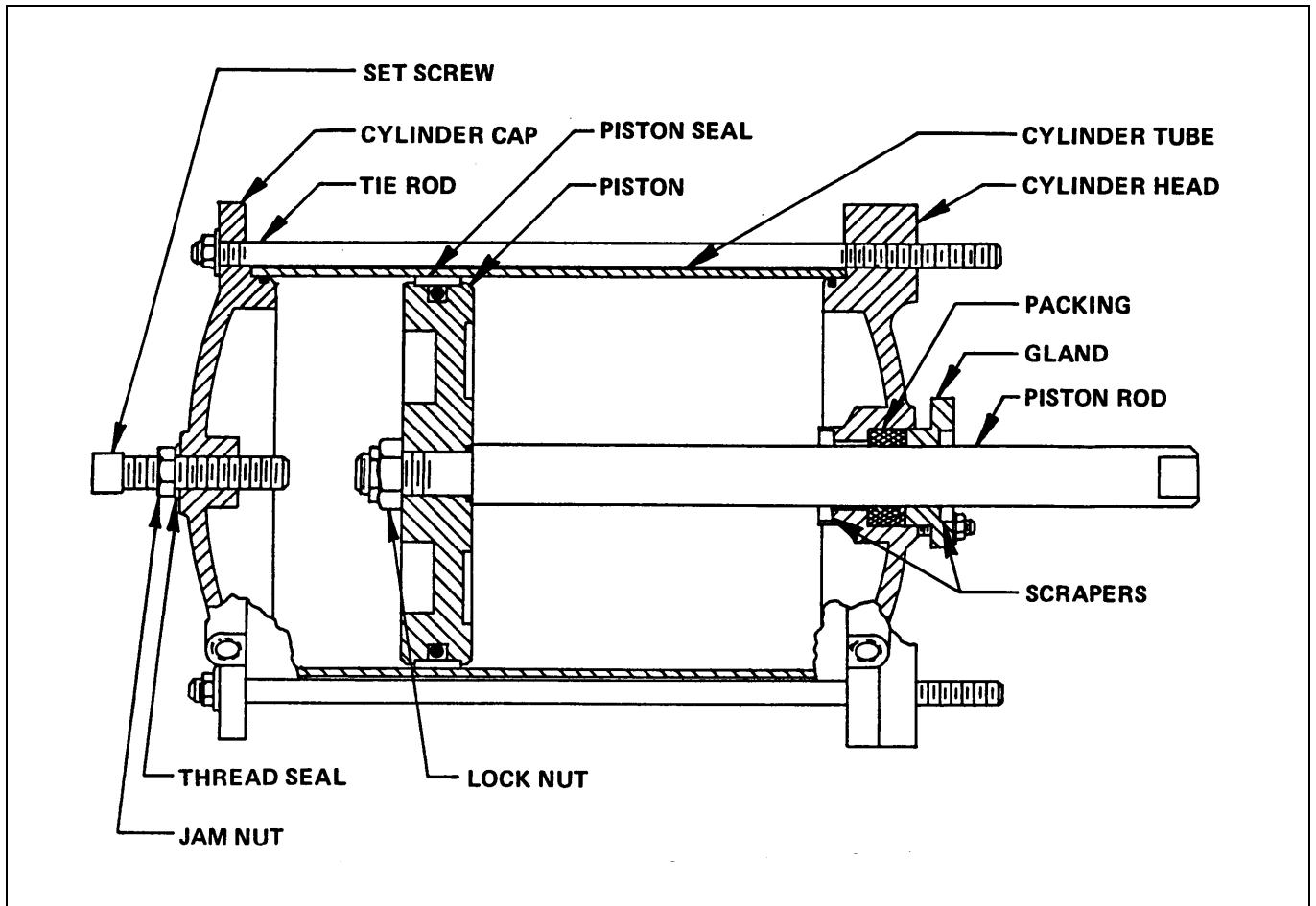

Figure 3 – Double-Acting Hydraulic Cylinder