

# Relays

## Series 61 Booster Relays

### Introduction

#### Features & Benefits

- ▶ Force-balance principle produces a proportional output for pneumatic circuit flexibility
- ▶ Built-in stability needle valve on the 61H and 61VH minimizes piping needs
- ▶ Improved valve stroking speed for better process control
- ▶ Epoxy powder coating provides improved corrosion resistance
- ▶ Accurate 1:1 signal relay provides pneumatic circuit design flexibility

#### Description

The Series 61 Booster Relays reproduce pneumatic signals in a 1:1 ratio for applications where input isolation or increased flow capacity are required. Various models are available to meet a wide range of requirements.

#### Valve Service

##### Model 61H High-Capacity Booster Relay

The Model 61H High-Capacity Booster Relay was designed to improve the stroking speed of large diaphragm valves. As such, it incorporates a stabilizing bypass needle valve between the input and output, eliminating the need for an externally piped bypass.

##### Model 61VH High-Capacity Booster Relay

The Model 61VH High-Capacity Booster Relay was designed for use on control valve actuators that require very fast stroking speeds. As such, it incorporates a stabilizing bypass needle valve between the input and output, eliminating the need for an externally piped bypass.

#### Pneumatic Control

##### Model 61L Moderate Accuracy Booster Relay

The Model 61L Moderate Accuracy Booster Relay combines moderate accuracy with a moderate capacity (approximately 4.5 scfm output at 9 psi). Like the Model 61H relay, this instrument is used primarily in straight forward valve-booster applications.

##### Model 61F High Accuracy Booster Relay

The Model 61F High Accuracy Booster Relay via the sensitive preformed diaphragms in this relay provides greater accuracy in 1:1 transmission. Its output capacity is about 1/4 that of the Model 61L. As such, it is suitable for use in measuring circuits.



*Model 61H is shown*

#### Model 61FE Booster Relay

The Model 61FE Booster Relay is similar to the Model 61F; however, it also includes a 1/8" NPT connection for those applications where a tapped exhaust is required.

#### Operation

Input pressure, acting upon the effective area of the upper diaphragm, produces a force that is opposed by the output pressure exerted upon the effective area of the lower diaphragm. The opposing forces are in a direct 1:1 ratio. As such, any increase in the input pressure will depress the diaphragm assembly and open the pilot valve to admit a sufficient supply of air to the output. This re-balances the input pressure. A decrease in input pressure will cause the diaphragm assembly to lift off the exhaust port, which reduces the output and re-balances the input.

# Relays

## Series 61 Booster Relays

### Technical data

#### Specifications

Model	61H	61L	61F & 61FE
Normal Input & Output Pressure	3-15	3-15	3-15
Maximum Input Pressure	100 psi	100 psi	50 psi
Maximum Supply Pressure	100 psi	100 psi	50 psi
Overload Protection to any Connection	100 psi	100 psi	100 psi
Accuracy of 1:1 Ratio	5%	2%	0.5%
Zero Error	----	3%	1%
Reproducibility <sup>1</sup>	0.1%	0.1%	0.02%
Linearity <sup>1</sup>	0.4%	0.4%	0.1%
Ambient Temperature Limits	-40 to 180°F		
Flow Capacity <sup>2</sup>	10.5 scfm	4.5 scfm	2.4 scfm

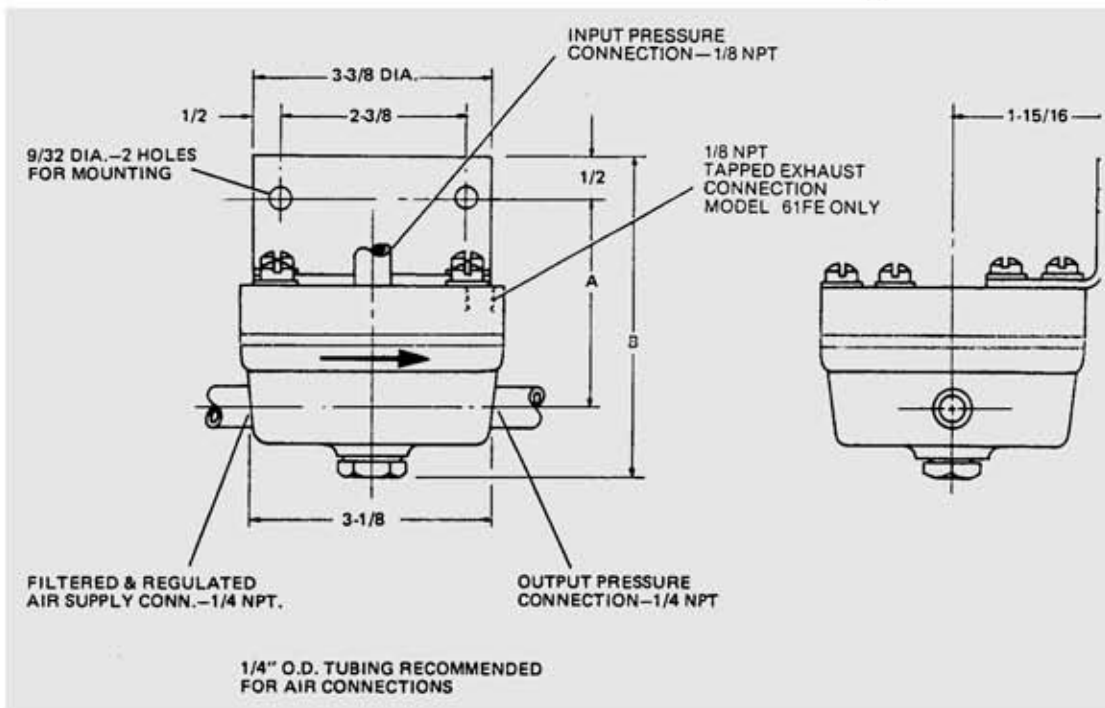

Model	A	B
61F, 61FE	2-13/16	4-3/16
61L	2-5/8	4

1) These performance figures are based on a 3-15 psi input.  
 2) Flow causes output pressure to droop 1 psi at 9 psi output with 20 psi supply.

# Relays

## Model 61H Booster Relays

### Technical data

4

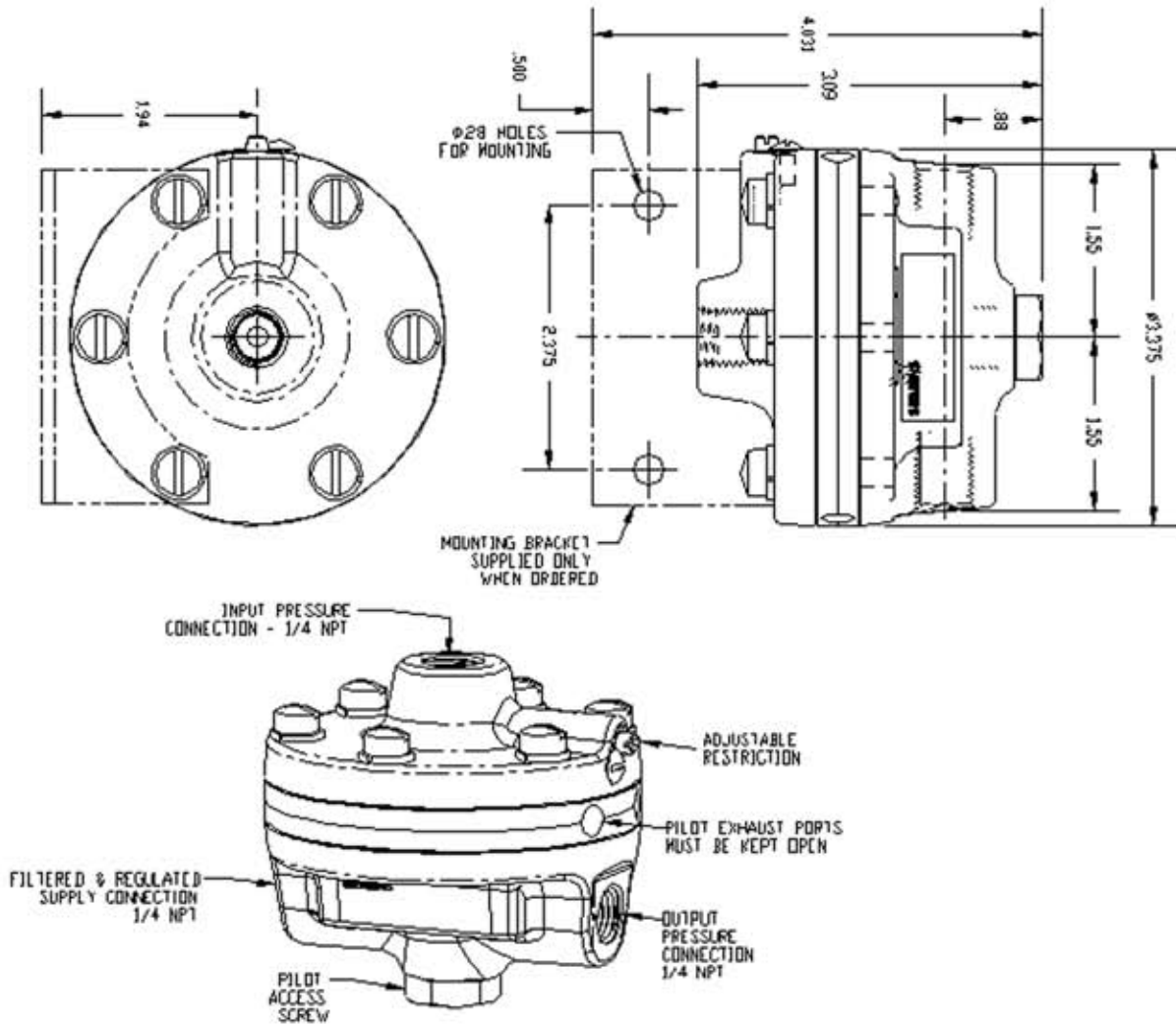

# Relays

## 61VH Booster Relay

### Technical data

