



# MODEL MG100 & MS100

# GROOVED & SMOOTH-END FLOWMETER

## DESCRIPTION

Model MG100 and MS100 meters are designed to provide high pressure rating and "Main Line" meter accuracy in an inexpensive package. The flowmeters are manufactured to comply with the applicable provisions of the American Water Works Association Standard No. C704-02 for propeller type flowmeters. The impeller and drive assembly are fully accessible through the open end of the meter tube.

Impellers are manufactured of high-impact plastic, capable of retaining their shape and accuracy over the life of the meter. Each impeller is individually calibrated at the factory to accommodate the use of any standard McCrometer register, and since no change gears are used, the flowmeters can be field-serviced without the need for factory recalibration. Factory lubricated stainless steel bearings are used to support the impeller shaft. The shielded bearing design limits the entry of materials and fluids into the bearing chamber providing maximum bearing protection.

An instantaneous flowrate indicator is standard and available in gallons per minute, cubic feet per second, liters per second and other units. The register is driven by a flexible steel cable encased within a protective vinyl liner. The register housing protects both the register and cable drive system from moisture while allowing clear reading of the flowrate indicator and totalizer.

## INSTALLATION

Standard installation is horizontal mount. If the meter is to be mounted in the vertical position, please advise the factory. A straight run of full pipe the length of ten pipe diameters upstream and two diameters downstream of the meter is recommended for meters without straightening vanes. Meters with optional straightening vanes require at least five pipe diameters upstream and two diameters downstream of the meter.

The Mc Propeller flow meter comes with a standard instantaneous flowrate indicator and straight-reading totalizer. An optional FlowCom register is also available.

Typical face plates.



Standard register

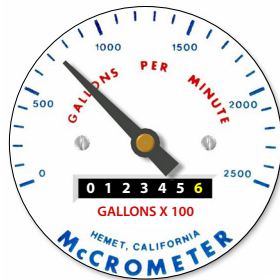

Optional 7-wheel totalizer

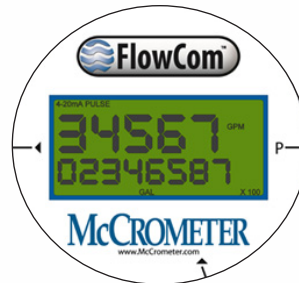

FlowCom register

## APPLICATIONS

The McCrometer propeller meter is the most widely used flowmeter for municipal and wastewater treatment applications as well as agricultural and turf irrigation measurement. Typical applications include:

- Center pivot systems
- Sprinkler irrigation systems
- Drip irrigation systems
- Golf course and park water management
- Gravity turnouts from underground pipelines
- Commercial Nurseries
- Water and Wastewater management

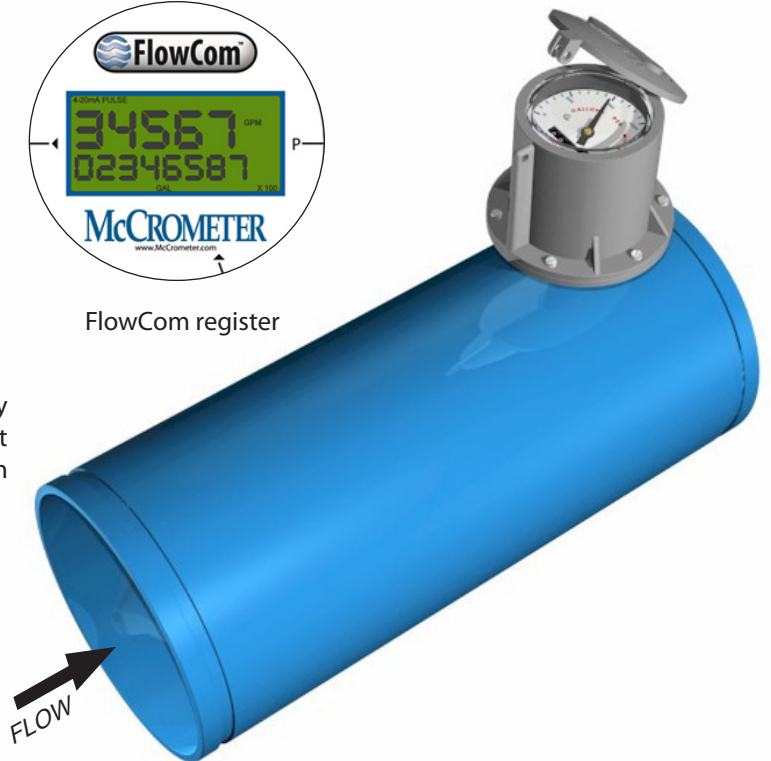

3255 WEST STETSON AVENUE • HEMET, CALIFORNIA 92545 USA

TEL: 951-652-6811 • 800-220-2279 • FAX: 951-652-3078 Printed In The U.S.A. Lit. # 24517-17 Rev. 2.1 / 2-23-18

Copyright © 2001-2017 McCrometer, Inc. All printed material should not be changed or altered without permission of McCrometer. Any published pricing, technical data, and instructions are subject to change without notice. Contact your McCrometer representative for current pricing, technical data, and instructions.



**MODEL MG100 & MS100**

**GROOVED & SMOOTH-END FLOWMETER**

**PERFORMANCE**

**ACCURACY/REPEATABILITY:** ±2% of reading guaranteed throughout full range. ±1% over reduced range. Repeatability 0.25% or better.

**RANGE:** (see dimensions chart below)

**HEAD LOSS:** (see dimensions chart below)

**MAXIMUM TEMPERATURE:** (Standard Construction) 160°F constant

**PRESSURE RATING:** 150 psi

**MATERIALS**

**TUBE:** Epoxy-coated carbon steel.

**BEARING ASSEMBLY:** Impeller shaft is 316 stainless steel. Ball bearings are 440C stainless steel.

**MAGNETS:** (Permanent type) Alnico

**BEARING HOUSING:**

- For models 2" to 16": 304 stainless steel standard, 316 stainless steel optional
- For models 18" and larger: Brass standard, 316 stainless steel optional

**IMPELLER:** Impellers are manufactured of high-impact plastic, retaining their shape and accuracy over the life of the meter. High temperature impeller is optional.

**REGISTER:** An instantaneous flowrate indicator and six-digit straight-reading totalizer are standard. The register is hermetically sealed within a die cast aluminum case. This protective housing includes a domed acrylic lens and hinged lens cover with locking hasp.

**COATING:** Fusion-bonded epoxy

**OPTIONS**

- Forward/reverse flow measurement
- High temperature construction
- "Over Run" bearing assembly for higher-than-normal flowrates
- Electronic Propeller Meter available in all sizes of this model
- A complete line of flow recording/control instrumentation
- Straightening vanes and register extensions available
- Certified calibration test results
- Canopy boot

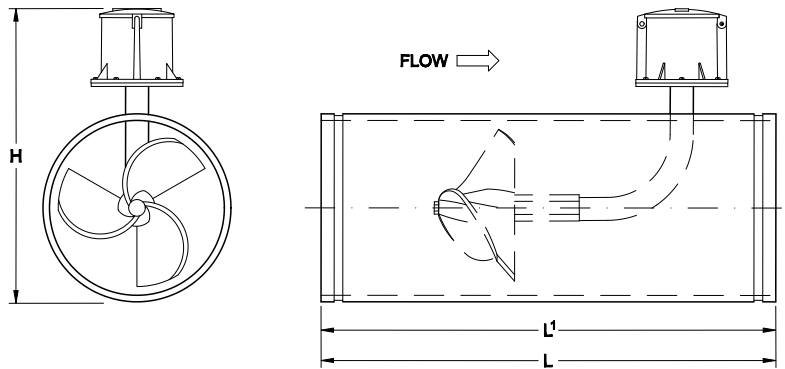

MG100 / MS100	DIMENSIONS												
Meter Size (inches)	2	2 ½	3	4	6	8	10	12	14	16	18	20	24
Maximum Flow U.S. GPM	250	250	250	600	1200	1500	1800	2500	3000	4000	5000	6000	8500
Minimum Flow U.S. GPM	40	40	40	50	90	100	125	150	250	275	400	475	700
Head Loss in Inches at Max. Flow	29.50	29.50	29.50	23.00	17.00	6.75	3.75	2.75	2.00	1.75	1.50	1.25	1.00
Shipping Weight, lbs.	* See Special Note		17	40	54	68	87	106	140	144	172	181	223
H (inches)			10.9	12.78	13.84	14.84	16.91	18.90	20.53	22.53	25.53	26.53	30.53
L (inches) MG100			13	20	20	20	20	20	20	22	22	22	22
L1 (inches) MS100			13	20	22	22	22	22	22	24	24	24	24
O.D. of Meter Tube			3.50	4.500	6.625	8.625	10.750	12.750	14.00	16.00	18.00	20.00	24.00

\*Special Note—Reducing fittings incorporating grooves are supplied to adapt the 3-inch model to smaller line sizes.

Larger flowmeters on special order.



3255 WEST STETSON AVENUE • HEMET, CALIFORNIA 92545 USA

TEL: 951-652-6811 • 800-220-2279 • FAX: 951-652-3078 Printed In The U.S.A. Lit. # 24517-17 Rev. 2.1 / 2-23-18

Copyright © 2001-2017 McCrometer, Inc. All printed material should not be changed or altered without permission of McCrometer. Any published pricing, technical data, and instructions are subject to change without notice. Contact your McCrometer representative for current pricing, technical data, and instructions.