

Datasheet

The Sure Cross Vibration and Temperature Sensor works in a variety of machines to identify and predict failures in rotating machinery.



- Detects dual-axis vibration
- Provides high accuracy vibration and temperature measurements
- Manufactured with a robust zinc alloy housing
- Functions as a Modbus slave device via RS-485



WARNING: Not To Be Used for Personnel Protection

Never use this device as a sensing device for personnel **protection**. Doing so could lead to serious injury or death. This device does not include the self-checking redundant circuitry necessary to allow its use in personnel safety applications. A sensor failure or malfunction can cause either an energized or de-energized sensor output condition.

For additional information, updated documentation, and a list of accessories, refer to Banner Engineering's website, www.bannerengineering.com/wireless.

Models

Model	Power Requirements	Connection and Cable	I/O
QM42VT2	3.6 to 5.5 V dc or 10 to 24 V dc	3 m cable with a 5-pin M12/Euro-style male quick disconnect (OD)	Vibration and temperature via RS-485 Modbus
QM42VT2QP		150 mm (6 in) PVC cable with a 5-pin M12/Euro-style male quick disconnect (OD)	

Configure this sensor using the [Sensor Configuration Tool](#) and adapter cable BWA-HW-006 (datasheet [140377](#)).

ISO 10816 provides guidance for evaluating vibration velocity severity motors, pumps, fans, compressors, gear boxes, blowers, dryers, presses, and other machines that operate in the 10 to 1000 Hz frequency range.

Vibration Velocity Vrms	Machine		Class I	Class II	Class III	Class IV
	in/s	mm/s	Small Machines	Medium Machines	Large Rigid Foundation	Large Soft Foundation
0.01	0.28					
0.02	0.45					
0.03	0.71			good		
0.04	1.12					
0.07	1.80					
0.11	2.80			satisfactory		
0.18	4.50					
0.28	7.10			unsatisfactory		
0.44	11.2					
0.70	18.0					
1.10	28.0			unacceptable		
1.77	45.9					

Figure 1. Vibration Severity per ISO 10816

Installation Instructions

Connecting the Vibration/Temperature Sensor

To install the sensor to a device with a 5-pin M12/Euro-style female connector:

1. Align the notch in the female connector with the key in the sensor's male connector.
2. Gently slide the sensor end into the connector.
3. Rotate the threaded nut to tighten the sensor down.



Wiring

This sensor is designed for use as a Modbus slave. This sensor can be plugged into any Modbus RS-485 network, including compatible Nodes and MultiHop Data Radios.

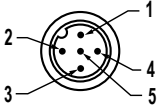
5-pin M12/Euro-style Male Connector	Pin	Wire Color	Sensor Connection
	1	Brown	Power IN (+). Either 3.6 to 5.5 V dc or 10 to 24 V dc
	2	White	RS485 / D1 / B / +
	3	Blue	Ground (-)
	4	Black	RS485 / D0 / A / -
	5	Gray	Not Used (default) or Discrete NPN Select Line (optional)

Installing the VT1 or VT2 Sensor

The vibration sensors have an X and Z axis indication on the face of the sensor. The Z axis goes in a plane through the sensor while the X is parallel to the sensor.

- Install the X axis in line with the shaft of the motor or axially.
- Install the Z axis to go into or through the motor or radial.

For the best results, install the sensor as close to the motor bearing as possible. If this is not possible, install the sensor on a surface that is in rigid connection with vibration characteristics of the motor. Using a cover shroud or other flexible mounting location may result in reduced accuracy or reduced ability to detect certain vibration characteristics.

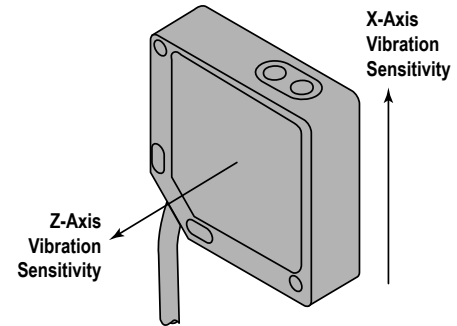

After determining the sensor direction and location, mount the sensor for the best possible vibration sensing accuracy. Mounting options in order from least effective to most effective are as follows:

Mounting Options	Effectiveness	Description
BWA-HW-057 Thermally Conductive Adhesive tape	Least effective	Often provides a more than sufficient mounting type but does introduce some additional flex that reduces accuracy
BWA-BK-001 Flat magnet sensor bracket		Gives a solid, strong, and adjustable mount to a motor, but with a motor's curved surface it may not provide the best connection if the motor is too small for the magnet to get a full connection with the motor housing. Magnet mounts are susceptible to accidentally rotation or change in sensor location if an outside force bumps or moves the sensor. This can lead to a change in sensor information that differs from the time-trended data from the previous location.
BWA-BK-008 Curved surface magnet attached to sensor bracket via ¼-28 bolt		Curved surface magnet mounts may provide a stronger mount to smaller curved motor surfaces than a flat magnet mount and need to be oriented in the correct direction for the strongest mount. If the magnet feels loose, rotate the magnet 45° or 90° and check again for the strongest connection. Magnet mounts are susceptible to accidentally rotation or change in sensor location if an outside force bumps or moves the sensor. This can lead to a change in sensor information that differs from the time-trended data from the previous location.
BWA-BK-002 or BWA-BK-005 Flat bracket epoxied to motor and sensor screwed to bracket Recommend using an epoxy designed for accelerometer mounting, such as Loctite Depend 330 and 7388 activator.		Epoxying a bracket to a motor provides a permanent installation of the bracket to which the sensor can be attached. This more rigid mounting solution ensures some of the best sensor accuracy and frequency response, but is not flexible for future adjustments.
BWA-BK-002 or BWA-BK-005 Flat bracket with direct screw mount to motor and sensor	Most effective	When available, directly mounting the bracket to the motor using a ¼-28 bolt provides a rigid surface with the highest sensor accuracy and frequency response. This mounting option offers flexibility for future sensor and bracket movement.

Configuration Instructions

Sensor Configuration Tool

The Sensor Configuration Tool offers an easy way to manage sensor parameters, retrieve data, and visually show sensor data from a number of different sensors. The Sensor Configuration Tool software runs on any Windows machine and uses an adapter cable to connect the sensor to your computer.

Download the most recent version of the Sensor Configuration Tool from Banner Engineering's website: www.bannerengineering.com/wireless. The Sensor Configuration Tool currently supports the following sensors:

Sensor Type	Model	USB Adapter Cable
Temperature and Humidity	M12FTH3Q and M12FT3Q	Model BWA-HW-006: USB-to-RS-485 adapter cable
	M12FTH4Q and M12FT4Q	Model BWA-USB1WIRE-001: USB-to-RS-232 1-Wire adapter cable
Vibration and Temperature	QM42VT1	Model BWA-USB1WIRE-001: USB-to-RS-232 1-Wire adapter cable
	QM42VT2	Model BWA-HW-006: USB-to-RS-485 adapter cable
GPS	GPS50M	Model BWA-HW-006: USB-to-RS-485 adapter cable AND a field-wireable M12/Euro-style connector or connector with pigtail
U-GAGE K50U Ultrasonic	K50UX1RA	Model BWA-USB1WIRE-001: USB-to-RS-232 1-Wire adapter cable
	K50UX2RA	Model BWA-HW-006: USB-to-RS-485 adapter cable

Launch the Sensor Configuration Tool and from the drop-down list, select your sensor type and click OK.

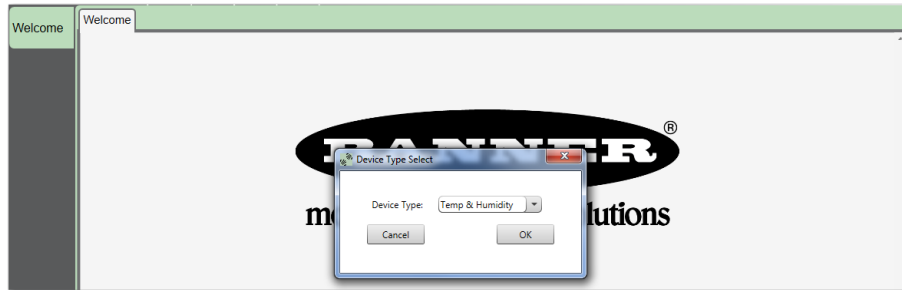

Holding Registers

By default, data is sampled every five seconds. Use the Sensor Configuration Tool to adjust the sensor's sample rate if a different value is needed.

Modbus Register Alias Address	Modbus Register Address	Description	I/O Range		Holding Register Representation	
			Min	Max	Min (dec)	Max (dec)
45201	42401	Z-Axis RMS Velocity (in/sec) ^{1, 5}	0	6.5535	0	65535
45202	42403	Z-Axis RMS Velocity (mm/sec) ^{2, 5}	0	65.535	0	65535
45203	40049	Temperature (°F) ³	-327.68	327.67	-32768	32767
45204	40043	Temperature (°C) ³	-327.68	327.67	-32768	32767
45205	42451	X-Axis RMS Velocity (in/sec) ^{1, 5}	0	6.5535	0	65535
45206	42453	X-Axis RMS Velocity (mm/sec) ^{2, 5}	0	65.535	0	65535
45207	42407	Z-Axis Peak Acceleration (G) ^{2, 6}	0	65.535	0	65535
45208	42457	X-Axis Peak Acceleration (G) ^{2, 6}	0	65.535	0	65535
45209	42405	Z-Axis Peak Velocity Component Frequency (Hz) ^{4, 5}	0	6553.5	0	65535
45210	42455	X-Axis Peak Velocity Component Frequency (Hz) ^{4, 5}	0	6553.5	0	65535
45211	42406	Z-Axis RMS Acceleration (G) ^{2, 5}	0	65.535	0	65535
45212	42456	X-Axis RMS Acceleration (G) ^{2, 5}	0	65.535	0	65535
45213	42409	Z-Axis Kurtosis ^{2, 6}	0	65.535	0	65535
45214	42459	X-Axis Kurtosis ^{2, 6}	0	65.535	0	65535
45215	42408	Z-Axis Crest Factor ^{2, 6}	0	65.535	0	65535
45216	42458	X-Axis Crest Factor ^{2, 6}	0	65.535	0	65535
45217	42402	Z-Axis Peak Velocity (in/sec) ^{1, 5}	0	6.5535	0	65535
45218	42404	Z-Axis Peak Velocity (mm/sec) ^{2, 5}	0	65.535	0	65535
45219	42452	X-Axis Peak Velocity (in/sec) ^{1, 5}	0	6.5535	0	65535
45220	42454	X-Axis Peak Velocity (mm/sec) ^{2, 5}	0	65.535	0	65535
45221	42410	Z-Axis High-Frequency RMS Acceleration (G) ^{2, 6}	0	65.535	0	65535
45222	42460	X-Axis High-Frequency RMS Acceleration (G) ^{2, 6}	0	65.535	0	65535

Modbus Register Alias Address	Modbus Register Address	Description	I/O Range		Holding Register Representation	
			Min	Max	Min (dec)	Max (dec)
	46101	Baud	0=9.6k, 1=19.2k (default), 2=38.4k			
	46102	Parity	0=none (default), 1=odd, 2=even			
	46103	Modbus Slave Address	1 (default) through 247			
	42601	Rotational Speed (RPM) (default = 1725 RPM) -- Used in vibration spectral band measurements	0	65535	0	65535
	42602	Rotational Speed (Hz) (default = 29 Hz) -- Used in vibration spectral band measurements	0	65535	0	65535

Aliased register addresses are user configurable. Aliased addressed registers are sequenced to be read with one single Modbus read.

¹ Value = Register value ÷ 10000

² Value = Register value ÷ 1000

³ Value = Register value ÷ 100

⁴ Value = Register value ÷ 10

⁵ Measurement bandwidth = 10 Hz to 1 kHz

⁶ Measurement bandwidth = 1 kHz to 4 kHz

Vibration Spectral Band Measurements

To use vibration spectral band measurements, enter the rotational speed of the machinery to monitor into the Sure Cross Vibration and Temperature Sensor in one of two ways:

- Use the Sensor Configuration Tool application, or
- Write the rotational speed in RMS to Modbus register 42601 or in Hz to Modbus register 42602.

Table 1: Values in Inches/Second

Rotational Speed Multiplier	Modbus Register Address (Floating Point Modbus) (IEEE 754 format)				Description
	Z-Axis		X-Axis		
	Upper	Lower	Upper	Lower	
1x	43501	43502	43531	43532	Band Total RMS Velocity (in/s)
	43503	43504	43533	43534	Band Peak Velocity Component RMS (in/s)
	43505	43506	43535	43536	Band Peak Velocity Component Bin (index)
	43507	43508	43537	43538	Band Peak Velocity Component Frequency (Hz)
	43509	43510	43539	43540	Band Peak Velocity Component RPM
2x	43511	43512	43541	43542	Band Total RMS Velocity (in/s)
	43513	43514	43543	43544	Band Peak Velocity Component RMS (in/s)
	43515	43516	43545	43546	Band Peak Velocity Component Bin (index)
	43517	43518	43547	43548	Band Peak Velocity Component Frequency (Hz)
	43519	43520	43549	43550	Band Peak Velocity Component RPM
3x-10x	43521	43522	43551	43552	Band Total RMS Velocity (in/s)
	43523	43524	43553	43554	Band Peak Velocity Component RMS (in/s)
	43525	43526	43555	43556	Band Peak Velocity Component Bin (index)
	43527	43528	43557	43558	Band Peak Velocity Component Frequency (Hz)
	43529	43530	43559	43560	Band Peak Velocity Component RPM

Table 2: Values in Millimeters/Second

Rotational Speed Multiplier	Modbus Register Address (Floating Point Modbus) (IEEE 754 format)				Description
	Z-Axis		X-Axis		
	Upper	Lower	Upper	Lower	
1x	43561	43562	43591	43592	Band Total RMS Velocity (mm/s)
	43563	43564	43593	43594	Band Peak Velocity Component RMS (mm/s)
	43565	43566	43595	43596	Band Peak Velocity Component Bin (index)
	43567	43568	43597	43598	Band Peak Velocity Component Frequency (Hz)

Rotational Speed Multiplier	Modbus Register Address (Floating Point Modbus) (IEEE 754 format)				Description
	Z-Axis		X-Axis		
	Upper	Lower	Upper	Lower	
2x	43569	43570	43599	43600	Band Peak Velocity Component RPM
	43571	43572	43601	43602	Band Total RMS Velocity (mm/s)
	43573	43574	43603	43604	Band Peak Velocity Component RMS (mm/s)
	43575	43576	43605	43606	Band Peak Velocity Component Bin (index)
	43577	43578	43607	43608	Band Peak Velocity Component Frequency (Hz)
	43579	43580	43609	43610	Band Peak Velocity Component RPM
3x-10x	43581	43582	43611	43612	Band Total RMS Velocity (mm/s)
	43583	43584	43613	43614	Band Peak Velocity Component RMS (mm/s)
	43585	43586	43615	43616	Band Peak Velocity Component Bin (index)
	43587	43588	43617	43618	Band Peak Velocity Component Frequency (Hz)
	43589	43590	43619	43620	Band Peak Velocity Component RPM

Specifications

Supply Voltage

3.6 to 5.5 V dc or 10 to 24 V dc

Current

Active comms: 8.8 mA at 24 V dc

Communication

Interface: RS-485 serial
 Baud rates: 9.6k, 19.2k (default), or 38.4k
 Data format: 8 data bits, no parity (default), 1 stop bit (even or odd parity available)
 Protocol: Modbus RTU

Mounting Options

The sensor can be mounted using a variety of methods, including 1/4"-28 hex screw, epoxy, thermal tape, or magnetic mount.

Shock

400G

Certifications



Vibration Sensor

Mounted base resonance: 4.5 kHz nominal
 Measuring Range: 0 to 46 mm/sec or 0 to 1.8 in/sec RMS
 Frequency Range: 10 Hz to 4 kHz
 Accuracy: ±10% at 25 °C
 Sampling Frequency: 20 kHz (default)
 Record Length: 8192 points (default)
 Sample Duration: 0.4 s (default)

Indicators

Green flashing: Power ON
 Amber flicker: Serial Tx

Temperature Sensor

Measuring Range: -40 °C to +105 °C (-40 °F to +221 °F)
 Resolution: 1 °C
 Accuracy: ± 3 °C
 Operating the sensor at higher voltages can induce internal heating that can reduce the accuracy.

Environmental Rating

NEMA 6P, IEC IP67

Operating Temperature

-40 °C to +105 °C (-40 °F to +221 °F) ¹

Dimensions

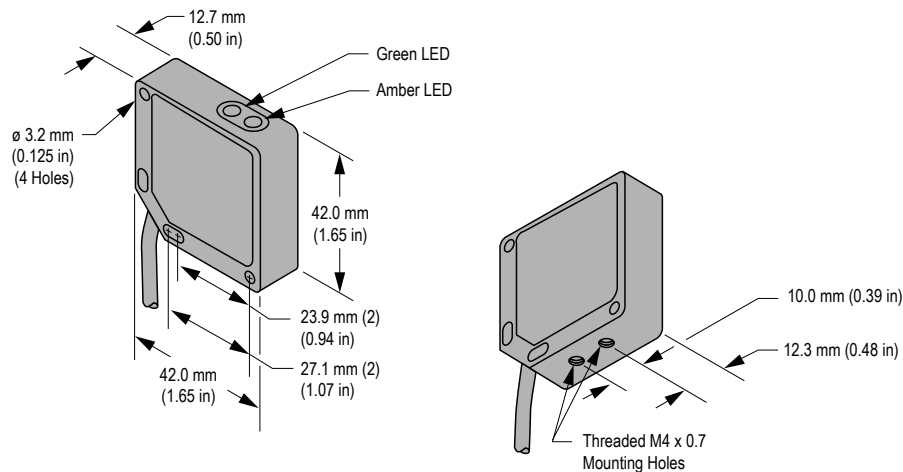

¹ Operating the devices at the maximum operating conditions for extended periods can shorten the life of the device.

Vibration and Temperature Sensor Accessories

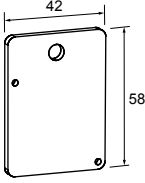
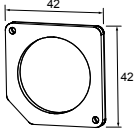
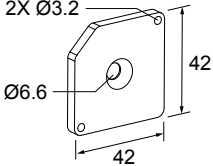
Included with Sensor	Available for Order
<p>BWA-BK-002</p> <ul style="list-style-type: none"> Includes SMB42FL stainless steel bracket, 1/4"-28 screw mount, and 1 piece of 3M™ thermally conductive adhesive transfer tape 	<p>BWA-BK-001</p> <ul style="list-style-type: none"> Includes magnetic mounting bracket SMB42FLM12 and 2 mounting screws 
<p>BWA-HW-057</p> <ul style="list-style-type: none"> 3M™ Thermally Conductive Adhesive Transfer Tape 8820 Provides a heat-transfer path between heat-generating components and heat sinks or other cooling devices 3 pieces per pack Tape is 20 mils (0.50 mm) thick; liner is 1.5-2 mil (37.5-50 µm) thick Thermally conductive ceramic filler Dual liner using silicone-treated polyester: easy-release PET liner is clear, tight side PET liner is blue 	<p>BWA-HW-006</p> <ul style="list-style-type: none"> PC USB to RS-485 converter Use with the Sensor Configuration Tool software to communicate directly with RS-485 sensors Refer to datasheet 140377 for more information about wiring the adapter cable to this sensor
	<p>BWA-BK-005</p> <ul style="list-style-type: none"> Use when measuring high frequency vibrations or when mounting the sensor to curved surfaces Includes SMB42FLAT stainless steel bracket, 1/4"-28 screw mount, and 1 piece of 3M™ thermally conductive adhesive transfer tape 

Banner Engineering Corp. Limited Warranty

Banner Engineering Corp. warrants its products to be free from defects in material and workmanship for one year following the date of shipment. Banner Engineering Corp. will repair or replace, free of charge, any product of its manufacture which, at the time it is returned to the factory, is found to have been defective during the warranty period. This warranty does not cover damage or liability for misuse, abuse, or the improper application or installation of the Banner product.

THIS LIMITED WARRANTY IS EXCLUSIVE AND IN LIEU OF ALL OTHER WARRANTIES WHETHER EXPRESS OR IMPLIED (INCLUDING, WITHOUT LIMITATION, ANY WARRANTY OF MERCHANTABILITY OR FITNESS FOR A PARTICULAR PURPOSE), AND WHETHER ARISING UNDER COURSE OF PERFORMANCE, COURSE OF DEALING OR TRADE USAGE.

This Warranty is exclusive and limited to repair or, at the discretion of Banner Engineering Corp., replacement. IN NO EVENT SHALL BANNER ENGINEERING CORP. BE LIABLE TO BUYER OR ANY OTHER PERSON OR ENTITY FOR ANY EXTRA COSTS, EXPENSES, LOSSES, LOSS OF PROFITS, OR ANY INCIDENTAL, CONSEQUENTIAL OR SPECIAL DAMAGES RESULTING FROM ANY PRODUCT DEFECT OR FROM THE USE OR INABILITY TO USE THE PRODUCT, WHETHER ARISING IN CONTRACT OR WARRANTY, STATUTE, TORT, STRICT LIABILITY, NEGLIGENCE, OR OTHERWISE.

Banner Engineering Corp. reserves the right to change, modify or improve the design of the product without assuming any obligations or liabilities relating to any product previously manufactured by Banner Engineering Corp. Any misuse, abuse, or improper application or installation of this product or use of the product for personal protection applications when the product is identified as not intended for such purposes will void the product warranty. Any modifications to this product without prior express approval by Banner Engineering Corp will void the product warranties. All specifications published in this document are subject to change; Banner reserves the right to modify product specifications or update documentation at any time. Specifications and product information in English supersede that which is provided in any other language. For the most recent version of any documentation, refer to: www.bannerengineering.com.