

Belt Weighing

Belt scales

Milltronics WD600

Overview



Milltronics WD600 is a light- to medium-duty slider bed belt scale used for process and load-out control in manufacturing, including the food, pharmaceutical and tobacco industries.

Benefits

- Simple installation
- Long weigh span for more retention time on load cells

Application

WD600 works with an existing flat belt conveyor and the selected Siemens integrator. As material is moving along the conveyor belt and travels over the belt scale, it exerts a force proportional to the material load through the suspended weighbridge to the load cells.

WD600 reacts only to the vertical component of the applied force. The resulting movement in each load cell is sensed by its strain gauges. When the strain gauges are excited by voltage from the electronic integrator, they produce an electrical signal proportional to weight, which is then applied to the integrator.

The vertical movement of the load cells is limited by the positive overload stop incorporated into the design of the load cell mount.

Technical specifications

Milltronics WD600	
Accuracy¹⁾	± 0.5 ... 1 % totalization over 25 ... 100 % operating range, application dependent
Repeatability	± 0.1 %
Belt width	12, 18, 24, 30, 36, 42, 48 inch (300, 450, 600, 750, 900, 1 000, 1 200 mm)
Belt speed	2.0 m/s (400 fpm) maximum ²⁾
Capacity	Up to 100 t/h ²⁾
Conveyor incline	<ul style="list-style-type: none"> • ± 20° from horizontal, fixed incline • Up to ± 30° with reduced accuracy³⁾
Conveyor idler/slider profile	Horizontal
Loading	<ul style="list-style-type: none"> • Minimum 1.0 kg/m (0.6 lb/ft) • Maximum 76 kg/m (51 lb/ft)
Load cell	
Construction	17-4 PH (1.4568) stainless steel or nickel plated alloy steel Strain gauge protection: silicon (nickel plated version only)
Degree of protection	<ul style="list-style-type: none"> • Stainless steel: IP68 • Nickel plated alloy steel: IP66
Cable length	3 m (10 ft)
Excitation	10 V DC nominal, 15 V DC maximum
Output	2 mV/V
Non-linearity	0.02 % of rated output
Non-repeatability	0.01 % of rated output
Capacity	Stainless steel range: 6, 12, 30 kg Nickel-plated range: 10, 15, 20, 30, 50 kg
Overload	150 % of rated capacity
Temperature	<ul style="list-style-type: none"> • -40 ... +65 °C (-40 ... +149 °F) operating range • -10 ... +40 °C (14 ... 104 °F) compensated
Scale construction	<ul style="list-style-type: none"> • Stainless steel construction, bead blast finish (1 ... 6 µm, 40 ... 240 µin) • Acetal sliders
Hazardous locations	Consult the factory
Approvals	CE, UKCA, meets FDA/USDA requirements for food processing, RCM, EAC, KC

¹⁾ Accuracy subject to: on factory approved installations the belt scale system's totalized weight will be within the specified accuracy when compared to a known weighed material test sample. The test rate must be within the specified range of the design capacity and held constant for the duration of the test. The minimum material test sample must be equivalent to a sample obtained at the test flow rate for three revolutions of the belt or at least ten minutes running time, whichever is greater.

²⁾ Contact Siemens (http://www.automation.siemens.com/aspa_app) for consideration of higher values.

³⁾ Review by Siemens required (http://www.automation.siemens.com/aspa_app).

Selection and ordering data	Article No.	Article No.
Milltronics WD600 Belt scale: accuracy is $\pm 0.5 \dots 1$ % totalization over 25 ... 100 % operating range with capacity up to 100 t/h (110 STPH). Click on the Article No. for the online configuration in the PIA Life Cycle Portal.	7MH7185- A 0	Spare parts Load cells <u>Stainless steel</u> 6 kg (13.2 lb) 12 kg (26.4 lb) 30 kg (66.2 lb) <u>Nickel plated</u> 10 kg (22 lb) 15 kg (33.1 lb) 20 kg (44 lb) 30 kg (66.2 lb) 50 kg (110 lb) Slider bar middle UHMW PE (for old style WD600) Slider bar side UHMW PE (for old style WD600) Slider bar acetal Test chain 1.62 lb/ft (2.41 kg/m), 60 inch
Belt width 12 inch (300 mm) 18 inch (450 mm) 24 inch (600 mm) 30 inch (750 mm) 36 inch (900 mm) 42 inch (1 000 mm) 48 inch (1 200 mm)	1 2 3 4 5 6 7	7MH7725-1EG 7MH7725-1EH 7MH7725-1EJ 7MH7725-1EK 7MH7725-1EL 7MH7725-1EM 7MH7725-1EN 7MH7725-1EP 7MH7723-1KF 7MH7723-1KE 7MH7723-1KG 7MH7723-1NF
Load cell capacity <u>Nickel plated</u> 10 kg (22 lb) 15 kg (33.1 lb) 20 kg (44 lb) 30 kg (66.2 lb) 50 kg (110 lb) <u>Stainless steel</u> 6 kg (13.2 lb) 12 kg (26.4 lb) 30 kg (66.2 lb)	D E F G L H J K	Calibration Hanger Weights 200 g (0.4 lb) 500 g (1.1 lb) 1 000 g (2.2 lb) 2 000 g (4.4 lb) 3 500 g (7.7 lb) 5 000 g (11 lb) 7 500 g (16.5 lb) 8 500 g (18.7 lb) 10 000 g (22 lb) 12 000 g (26.5 lb) 15 000 g (33.1 lb) Note: calibration accessories should be ordered as a separate item on the order.
Further designs Please add "-Z" to article no. and specify order code(s). Stainless steel tag [69 x 38 mm (2.7 x 1.5 inch)]. Measuring-point number/identification (max 27 characters), specify in plain text. Application Eng. reference number (max. 15 characters), specify in plain text. Manufacturer's test certificate: According to EN 10204-2.2	Order Code Y15 Y31 C11	
Operating instructions All literature is available to download for free, in a range of languages, at http://www.siemens.com/weighing/documentation		

Belt Weighing

Belt scales

Milltronics WD600

Dimensional drawings

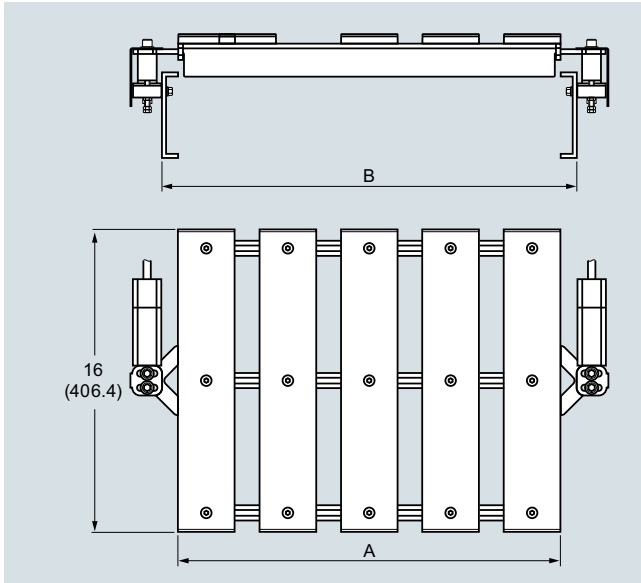

Belt width	A	B (min.)	B (max.)
12 (300)	14.25 (362)	15 (381)	16.5 (419)
18 (450)	20.25 (514)	21 (533)	22.5 (572)
24 (600)	26.25 (667)	27 (686)	28.5 (724)
30 (750)	32.25 (819)	33 (838)	34.5 (876)
36 (900)	38.25 (972)	39 (991)	40.5 (1 029)
42 (1 000)	44.25 (1 124)	45 (1 143)	46.5 (1 181)
48 (1 200)	50.25 (1 276)	51 (1 295)	52.5 (1 334)

WD600, dimensions in inch (mm)

4

Circuit diagrams

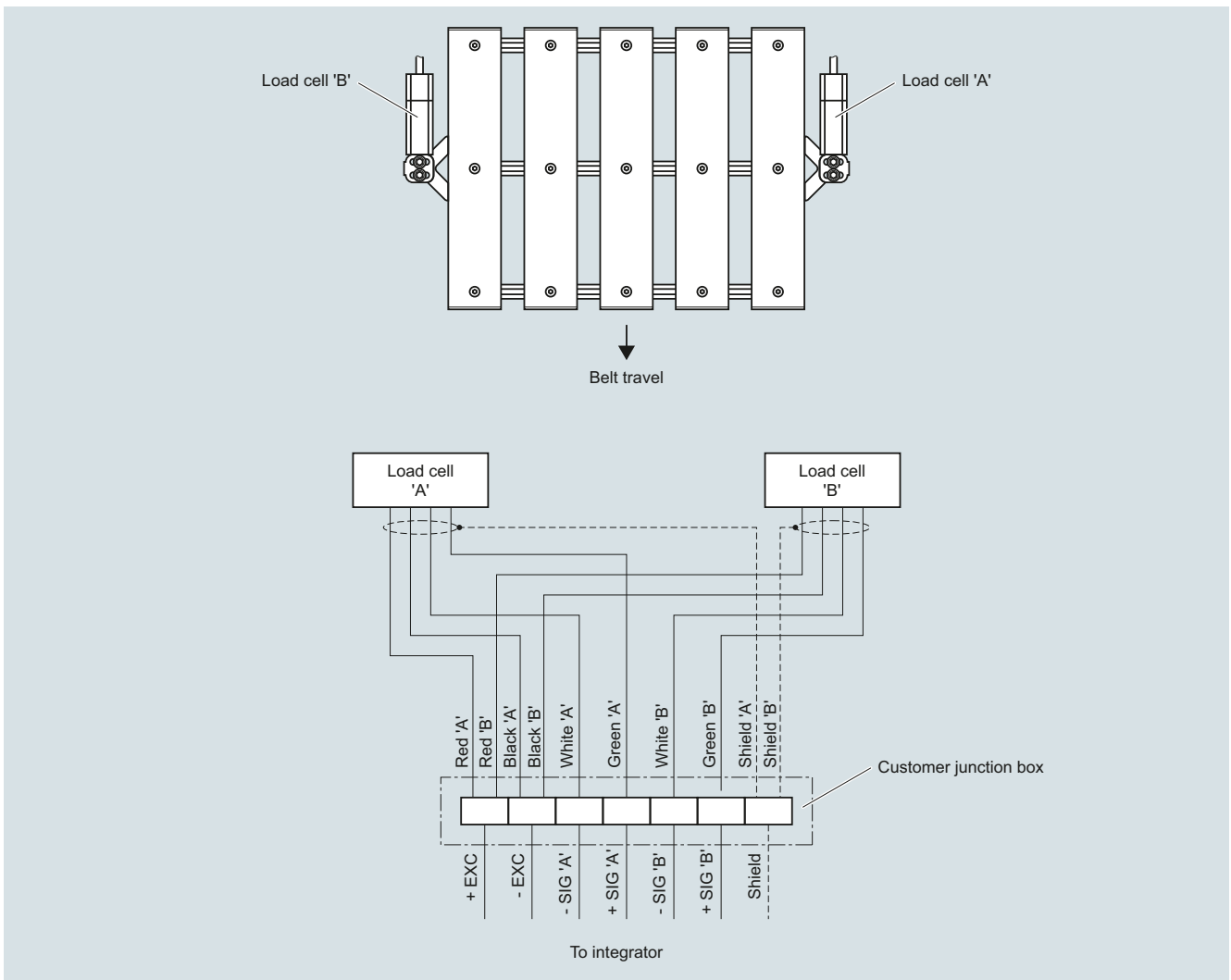

WD600 connections