

# 708HPA Series

## Fractional Flow Control Valves

### FRACTIONAL FLOW CONTROL VALVES

The Mark 708HPA is a 12,000 psi maximum inlet fractional flow control valve. This rugged, compact angle body control valve is suitable for a variety of high pressure industrial and research applications. The extended pressure capability makes it the ideal valve for offshore well system chemical injection. Linear and equal percentage flow characteristics are available with Cv's ranging from 0.05 (0,04 Kv) to 1.25 (1,1 Kv). In addition, the Mark 708HPA is available in a variety of end connections and optional materials of construction making it a versatile solution to your most demanding valve requirements.

#### Features:

- Union style body / bonnet connection – provides solid construction and secure connection. The metal 'C' ring gasket provides excellent sealing without exposing the bonnet threads to the media. Adds ease to maintenance, as bonnet and actuator assembly may be removed with the body in-line.
- Mechanically loaded PTFE Chevron heavy duty V ring packing – the adjustable packing arrangement maintains a proper compression, while minimizing excessive friction. The PTFE packing is suitable for temperature to 450°F (232°C), while mechanically loaded Graphoil may be used for higher temperature requirements.
- Rolling diaphragm – the rolling diaphragm design ensures that the effective diaphragm area remains relatively constant, regardless of valve stem position. This increases accuracy of the actuator while positioning the valve by ensuring a linear response to input signal changes.
- Guided trim – extended orifice and plug guiding are standard and offers improved shutoff and accuracy.
- Standard with side mount positioner

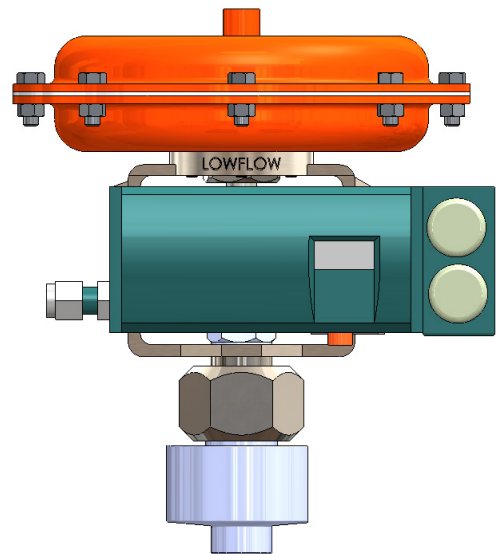

**MK708HPA SERIES SPECIFICATIONS**

Sizes: 1/2" (DN15)

**End Connections**

- Threaded – FNPT
- Socket weld
- Autoclave AE

**Actuator**

- 35M (35 in<sup>2</sup>)

**Diaphragm Material**

- Buna-N fabric reinforced

**Body/Bonnet Materials**

- 316/316L Stainless Steel barstock
- Monel barstock
- Alloy 20 barstock

**Trim Materials**

- Match body material with stellite plug/seat

**Actuator Materials**

- Steel – 35M

For other options/materials, consult factory

**Stem Packing**

- PTFE Chevron Heavy duty V ring - mechanically loaded
- Optional: Graphite/Graphoil - mechanically loaded

**Body/Bonnet Gasket:** Parker Seals Metal 'C' Ring Inconel X-750

**Service:** steam, air, gas, oil, water, chemicals

**Maximum Operating Pressure:**

- 12000 psi max inlet @ 100°F (827 bar max inlet @ 38°C)
- 7530 psi (519 bar) max ΔP ATC with positioner and 45 psig (3,1 bar) supply
- 5875 psi (405 bar) max ΔP ATO with positioner and 45 psig (3,1 bar) supply

**Maximum Operating Temperature:**

- 2680 psi (185 bar) max inlet @ 850°F (454°C) with Graphite/Graphoil packing
- 6580 psig (454 bar) max inlet @ 450°F (232°C) with TFE packing
- Standard – Cv's 0.05 and greater: ANSI Class III (Class IV optional); Cv's 0.02 and lower: ANSI Class VI
- Optional – Cv's 0.05 and greater: ANSI Class VI (with PEEK seats)

**MK708HPA SERIES BODY/BONNET CONNECTION**

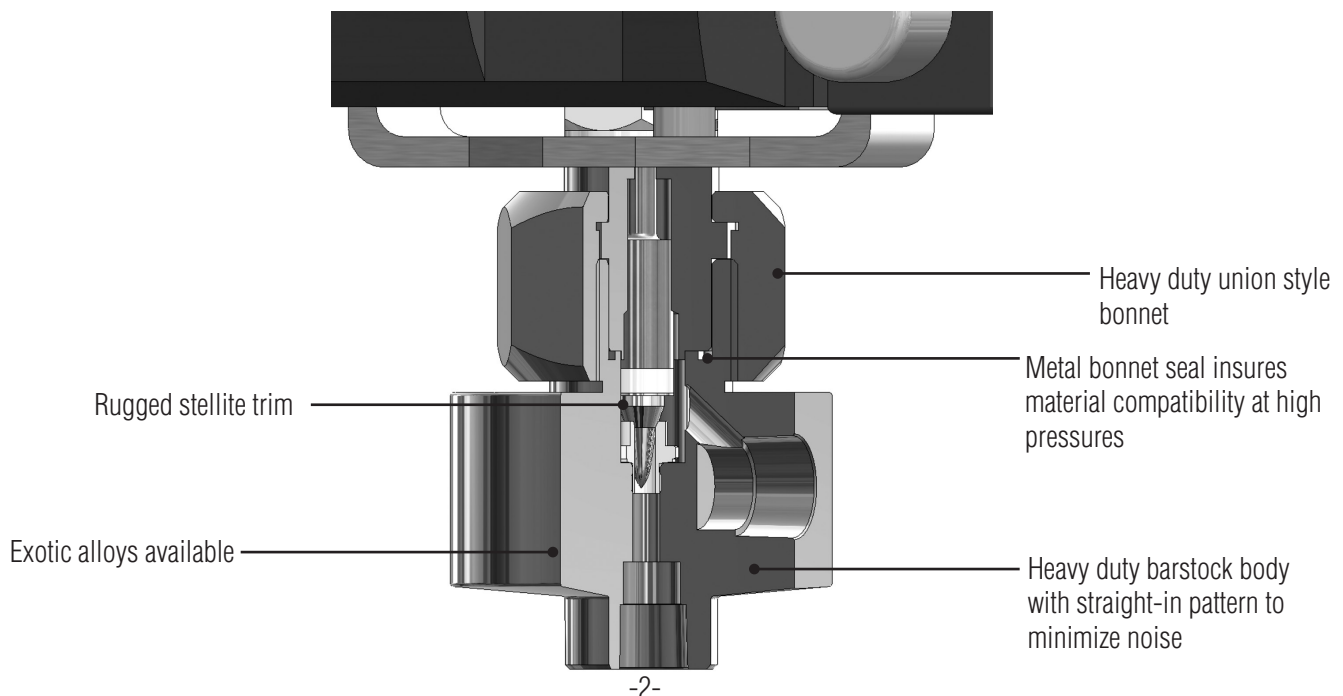

**MK708HPA SERIES DIMENSIONS**

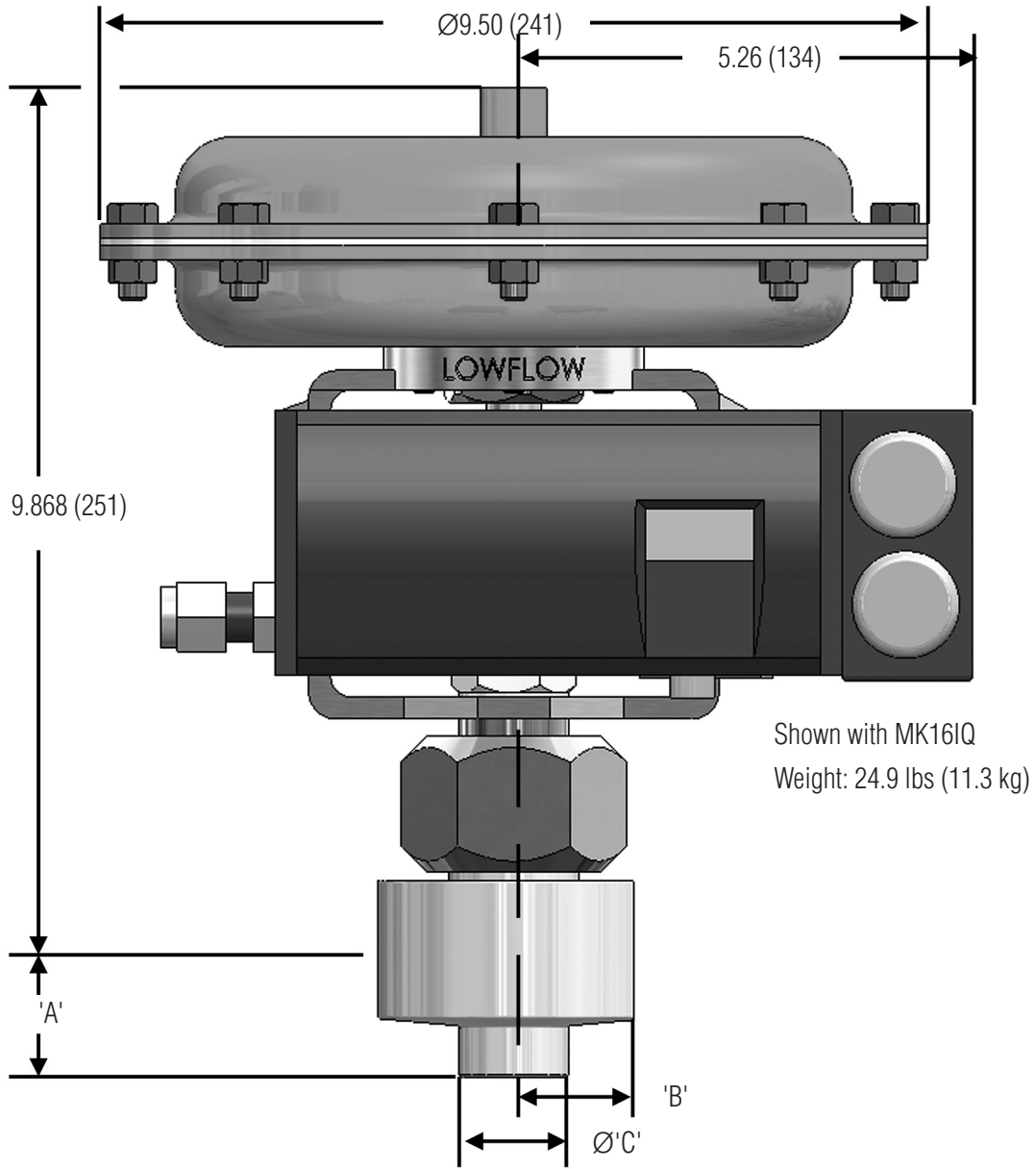

Dimensions (Inches)			
Port Type	A	B	C
Threaded	1.498	1.380	1.250
Autoclave	1.795	1.442	1.500

Dimensions (MM)			
Port Type	A	B	C
Threaded	38	35	31,8
Autoclave	45,6	36,6	38,1

## MK708HPA SERIES ORDERING SCHEMATIC

Model No.	Size	Body Mat'l	1	2	3	4	5	6	7	8	9	10	11	12	13	14	15	16	17

MODEL	
708HPA	Standard

SIZE	
050	1/2" (DN15)

BODY MATERIAL	
SB	Stainless Steel (316/316L) Bar
HC	Hastelloy C
MN	Monel Bar
A2	Alloy 20 Bar

1 & 2 END CONNECTIONS	
PT	NPT
SW	Socket Weld
AC	Autoclave AE
TN	Integral Tube Nuts
ZZ	Non-standard

3 & 4 TRIM	
T6	Teflon Packing
G6	Graphite/Graphoil
ZZ	Non-standard

5 & 6 PLUG SEAT			
	Material of Stem/Plug/Seat		Cv
M	NPT NIT60/Stellite/Stell-Lin. Hard	L	0.05
N	NPT NIT60/Stellite/Stell =% Hard	M	0.10
P	AE NIT60/Stellite/Stell-Lin. Hard	N	0.20
Q	AE NIT60/Stellite/Stell =% Hard	P	0.50
		Q	1.0
		W	1.25
ZZ	Non-standard		

7 & 8 RANGE			
	Range	Actuator	
A	Direct	3	35M
B	Reverse		
ZZ	Non-standard		

9 & 10 DIAPHRAGM			
	Material	Size	
B	Buna-N	3	35M
ZZ	Non-standard		

11 & 12 ACTUATOR			
	Type	Size	
S	With SMP	3	35M
ZZ	Non-standard		

13 & 14 ACCESSORIES	
00	None
AR	Air Regulator
S2	3-way Solenoid Energize to Open
S3	3-way Solenoid Energize to Close
ZZ	Non-standard

15 ACTION	
D	Air-to-close
R	Air-to-open

16 I/P	
0	None

17 SMP	
0	None
A	MK16 SMP Dir/Rev 3-15
B	MK16 SMP Dir/Rev 3-9
C	MK16 SMP Dir/Rev 9-15
D	MK16 SMP/IP Dir/Rev 4-20
E	MK16 SMP/IP Dir/Rev 4-12
F	MK16 SMP/IP Dir/Rev 12-20
G	MK 16IQ-S Dir/Rev 4-20
H	MK16IQ-B Dir/Rev 4-20
J	MK16IQ-FF Dir/Rev 4-20
Z	Non-standard