

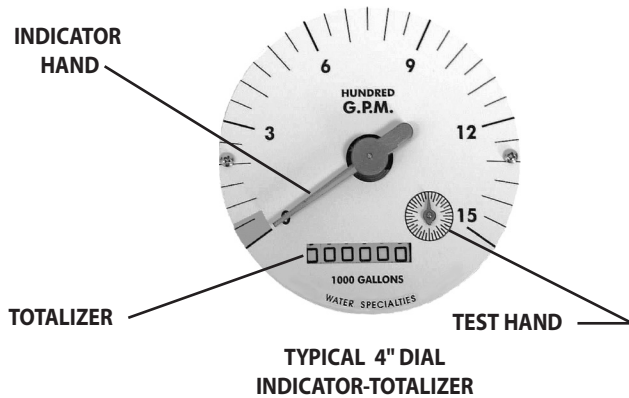

MODEL ML20
 150 psi WELDING SADDLE METER
 SEALED METER MECHANISM - MAGNETIC DRIVE
 INDICATOR - TOTALIZER
 SIZES 4" thru 72"



DESCRIPTION

MODEL ML20 WELDING SADDLE METERS are manufactured to the highest standards. Materials used on all meters and flow ranges for the low velocity meter meet or exceed AWWA standard C704-02. The weld-on design permits use in a wide range of applications with up to 150 psi working pressure. It is necessary, upon ordering, to furnish the I.D. dimension of the pipe the meter is to be mounted on for calibration purposes. The O.D. dimension or wall thickness must also be furnished for proper fit of the saddle to the pipe.

INSTALLATION is made by cutting a hole in the existing pipe line and then welding the saddle to the line. The removable meter head assembly can then be bolted to the saddle. The meter can be installed horizontally or inclined on suction or discharge lines. The meter must have a full flow of liquid for proper accuracy. Fully opened gate valves, fittings or other obstructions that tend to set up flow disturbances should be a minimum of ten pipe diameters upstream and two pipe diameters downstream from the meter. Installations with less than ten pipe diameters of straight pipe require straightening vanes. Meters with straightening vanes require at least five pipe diameters upstream and two pipe diameters downstream of the meter.

PROPELLER is magnetically coupled with the drive mechanism through the sealed oil filled gearbox. This completely eliminates water entering the meter assembly, as well as the need for any packing gland. The propeller is a conical shaped three bladed propeller, injection molded of thermoplastic material resistant to normal water corrosion and deformity due to high flow velocities.

BEARING is a water lubricated ceramic sleeve and spindle bearing system with a ceramic/stainless steel spindle. Dual ceramic thrust bearings, standard on all meters, handle flows in both forward and reverse directions. The bearing design promotes extended periods of maintenance free propeller operation. Bearings within the sealed meter mechanism are shielded precision stainless steel bearings and are factory lubricated for the life of the meter.

INDICATOR-TOTALIZER is mechanically driven by the meter mechanism and features a full 4" diameter, 250 degree sweep dial with a six digit, straight reading type totalizer and sweep test hand. The indicator drive mechanism is temperature compensated so the indicator will be accurate at all points on the dial when operated between 32° and 140° F. The indicator dial can be furnished in GPM, CFS, MGD or any standard liquid measuring units with choice of standard totalizer measuring units. The bonnet, with padlock hasp, is O-ring sealed to the meter head.

CHANGE GEARS may be easily exchanged in the field when changing the dial, or when recalibrating for different pipe sizes. It is not necessary to remove pressure from the line for these changes.

O-RING SEALS are used at the meter head and all points where seals are required, making the meter mechanism completely immune to any of the corrosive effects of atmospheric moisture or the liquids measured by the meter assembly.

SPECIFICATIONS

ACCURACY	Plus or minus 2% of actual flow within the range specified for each meter size.
PRESSURE RANGE	Up to 150 PSI maximum working pressure.
TEMPERATURE RANGE	140° F Maximum. Consult factory for special construction for higher temperatures.
MINIMUM FLOWS	As shown for each meter size and construction are required for accurate registration. See flow chart. NOTE: Minimum flow will be higher when auxiliary equipment is added.
MAXIMUM FLOWS	As shown for each meter size and construction are rated for continuous operation. See flow chart.
INTERMITTENT FLOWS	As shown for each meter size are rated for 10% to 15% of the total time the meter is operating. Consult factory for High Velocity construction when intermittent flows are higher than shown on flow chart and/or when longer operating periods are required.
MATERIALS	Used in construction are chosen to minimize the corrosive effects of the liquids measured by the meter assembly. MAGNETS - permanent ceramic type INTERIOR BEARINGS - shielded stainless steel PROPELLER BEARING - ceramic sleeve type (4"-54") or sealed stainless steel ball type (60"-72") PROPELLER SPINDLE - ceramic sleeve/stainless steel (4"-54") or stainless steel (60"-72") PROPELLER - injection molded thermoplastic GEARBOX - stainless steel (4"-54") SEPARATOR - stainless steel SHAFTS - stainless steel METER HEAD BOLTS - stainless steel (4"-20") or plated steel (24"-72") METER HEAD - cast iron or fabricated steel, NSF approved fusion epoxy coated.
OPTIONAL EQUIPMENT	Totalizer Extensions and a wide range of controls and instruments for indicating, totalizing and recording flow data for each meter. Special construction and materials are available upon request.
ORDERING INFO	Must be specified by the customer and includes: Minimum & maximum flow ranges Temperature of meter environment Indicator scale & units Totalizer dial units Type of materials and construction Optional equipment desired Pipe I.D. and O.D.

MODEL ML20
 150 psi WELDING SADDLE METER
 SEALED METER MECHANISM-MAGNETIC DRIVE
 INDICATOR-TOTALIZER
 SIZES 4" thru 72"

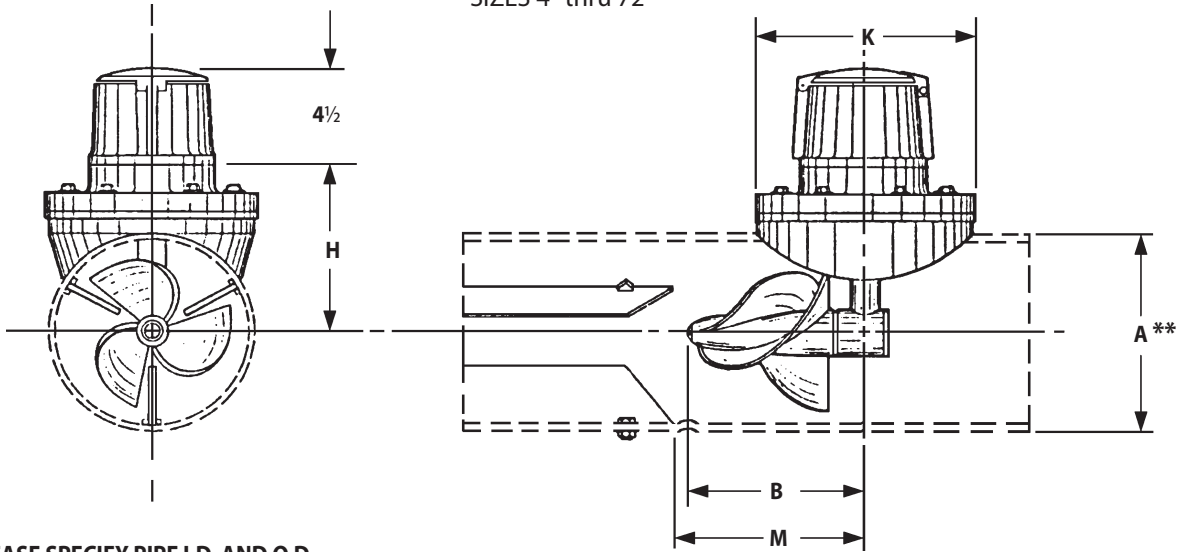

** PLEASE SPECIFY PIPE I.D. AND O.D.

METER & PIPE SIZE	FLOW RANGES, GPM		DIMENSIONS					EST SHIPPING WEIGHT POUNDS
	STANDARD CONSTRUCTION MIN. - MAX. - INT.	HIGH VELOCITY CONSTRUCTION MIN. - MAX.	A	B	H	K	M	
4	55-500-700	200-700	4½	8	5 ³ / ₁₆	9	10	55
6	120-1200-1500	300-1500	6 ⁵ / ₈	8	6¼	9	10	55
8	150-1500-2000	400-2500	8 ⁵ / ₈	8	7¼	9	10	55
10	180-2000-3000	500-3500	10¾	8	8½	11	10	60
12	200-3000-3500	800-5000	12¾	8	9½	11	10	70
14	300-4000-4500	1000-6000	14	8	10½	13½	10	75
16	400-5000-6000	1200-7500	16	8	11½	13½	10	75
18	700-6000-7500	1500-9000	18	8	12½	13½	10	75
20	850-8000-9000	2000-12000	20	8	13½	13½	10	75
24	1000-10000-13500	3000-15000	24	11½	17½	21	13½	250
30	1800-15000-21000	4000-25000	30	11½	20½	21	13½	250
36	2000-20000-30000	5000-35000	36	11½	23½	21	13½	250
42	3000-30000-40000	6000-50000	42	11½	27	32	13½	525
48	5500-35000-50000	7000-60000	48	11½	30	32	13½	525
54	6500-45000-55000	8000-65000	54	11½	33	32	13½	525
60	7500-60000-80000	10000-90000	60	18 [‡]	36	32	22 [‡]	525
66	8500-75000-95000	12000-105000	66	18 [‡]	39	32	22 [‡]	525
72	9500-90000-115000	15000-125000	72	18 [‡]	42	32	22 [‡]	525

Standard construction will be supplied for all main line meters unless special flow range, materials, or construction are required.

‡ On High Velocity Meters "B" Dimension is 11½" and "M" dimension is 13½".



www.mccrometer.com

3255 WEST STETSON AVENUE • HEMET, CALIFORNIA 92545 USA
 TEL: 951-652-6811 • FAX: 951-652-3078

Copyright © 2001-2013 McCrometer. All printed material should not be changed or altered without permission of McCrometer. The published technical data and instructions are subject to change without notice. Contact your McCrometer representative for current technical data and instructions.