

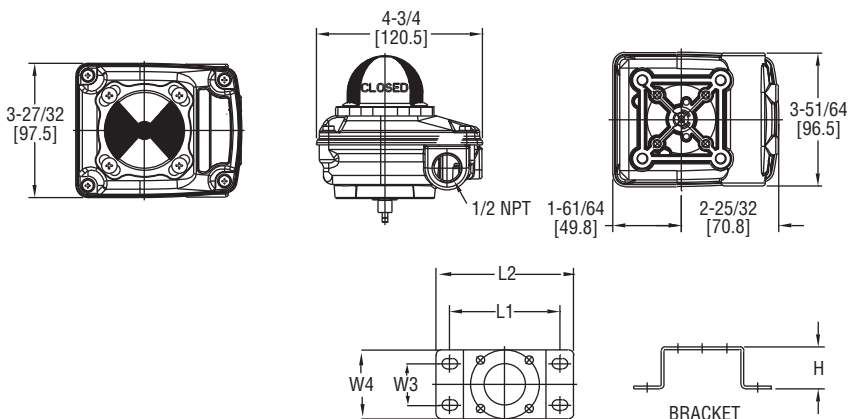

# Series VPI Valve Position Indicator

## Specifications - Installation and Operating Instructions

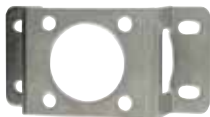

Bracket Dimensions					
Model	H in (mm)	L1 in (mm)	L2 in (mm)	W3 in (mm)	W4 in (mm)
VPI-B01	1-13/64 [30.5]				
VPI-B02	1-19/64 [40.5]	3-5/32 [80]	3-15/16 [100]	1-3/16 [30]	2 [50]
VPI-B03	1-19/64 [40.5]	5-1/8 [130]	5-29/32 [150]		
VPI-B04	2-3/8 [60.5]				

The Series VPI Rotary Valve Position Indicators are compact yet rugged for confined and severe locations. These versatile units offer visual position indication as well as two internal limit switches. The spring-loaded splined cams require no tools for a quick and precise adjustment. The Series VPI is available with mechanical or proximity limit switches. The mechanical models feature two SPDT limit switches. The proximity models feature two solid-state inductive limit switches eliminating the need for the cams to make contact with the switches. The NEMA 6 (IP67) rating ensures protection against the ingress of liquid and debris.

### ASSEMBLY

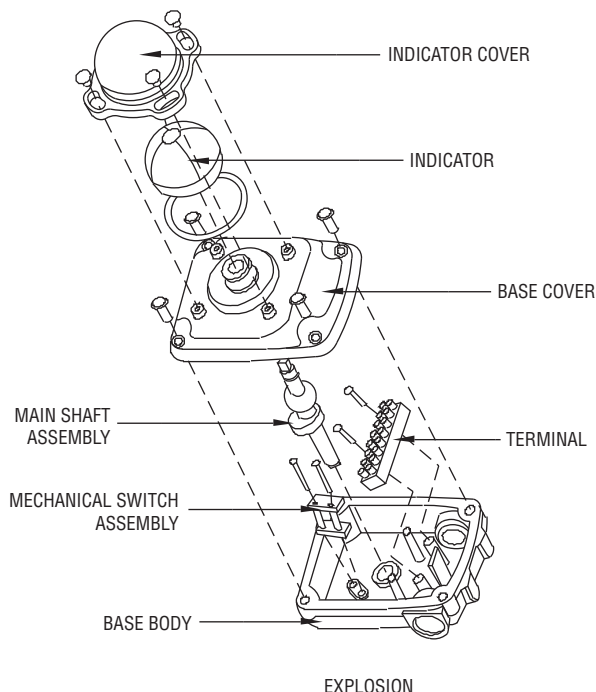

### SPECIFICATIONS

- Minimum Rotation Travel:** 60°.
- Maximum Rotation Travel:** 360°.
- Temperature Limits:** -4 to 176°F (-20 to 80°C).
- Switch Type:** VPI-M: (2) mechanical SPDT limit switches; VPI-P: (2) Inductive proximity limit switches.
- Electrical Rating:** VPI-M: AC: 3A at 250 V, 5A at 125 V; DC: 0.2A at 250 V, 0.4A at 125 V, 4A at 30 V.
- Power Requirements:** VPI-P: 12 to 24 VDC, 30 VDC maximum.
- Enclosure Material:** Aluminum die-casting.
- Electrical Connections:** 8-contact screw terminal strip.
- Conduit Connection:** (2) 1/2" female NPT.
- Enclosure Rating:** NEMA 6 (IP67).
- Mounting:** NAMUR.
- Weight:** 1.9 lb (0.88 kg).

## INSTALLATION

### Safety Warning



- VPI Series is designed for non-explosion use. The VPI should not be installed in explosives areas.
- All input and supply pressure to valve, actuator, and other related devices must be turned off when installing.

### VPI Installation

#### Installation Steps

1. Assemble limit switch body with the bracket.
2. Align main shaft of the limit switch box and the stem of the actuator. After the alignment, tighten the bracket onto the actuator.

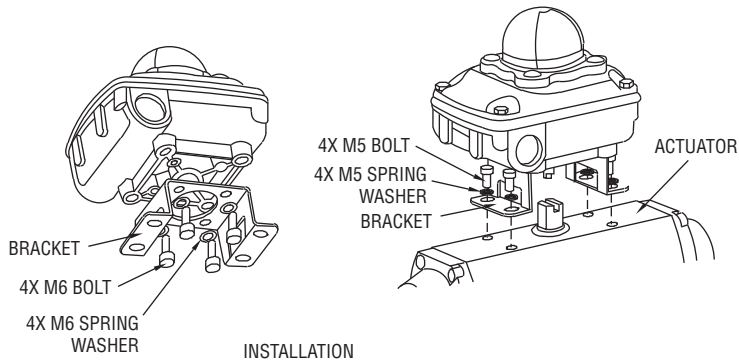

## WIRING

### Connection - Power

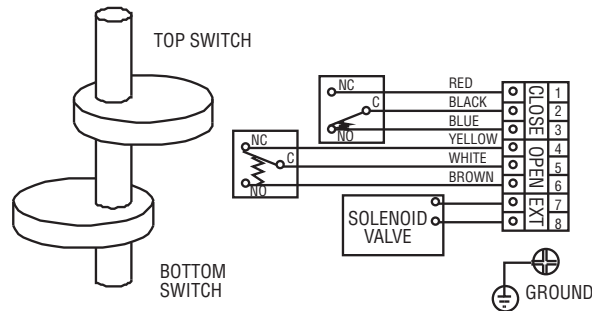

MECHANICAL TYPE <2 SPDT>

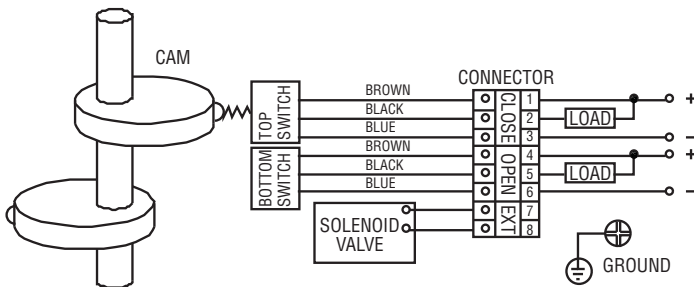

PROXIMITY TYPE <NPN SENSOR>

## ADJUSTMENT

### Adjustment - Upper Switch

Push down upper switch and turn right or left for switch adjustment.

ADJUSTMENT-UPPER SWITCH

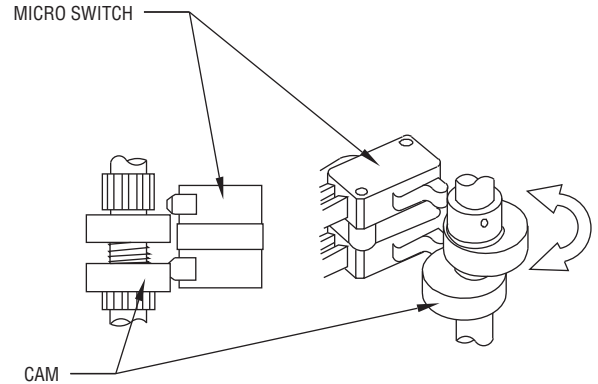

### Adjustment - Lower Switch

Pull up lower switch and turn right or left for switch adjustment.

ADJUSTMENT-LOWER SWITCH

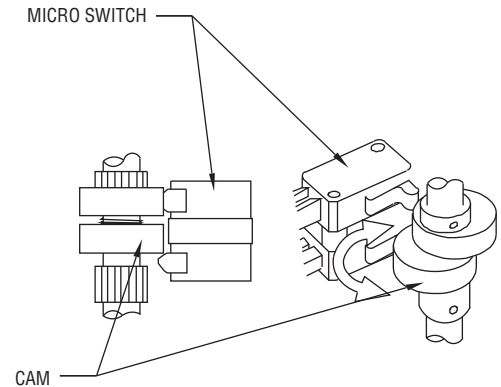

## MAINTENANCE

Upon final installation of the Series VPI Valve Position Indicator, no routine maintenance is required. A periodic check of system calibration is recommended. The Series VPI is not field serviceable and should be returned if repair is needed (field repair should not be attempted and may void warranty). Be sure to include a brief description of the problem plus any relevant application notes. Contact customer service to receive a return goods authorization number before shipping.