



**DeZURIK LA-SERIES
MANUAL & ELECTRIC
ACTUATORS**

Instruction **D10308**
August 2012

DeZURIK

LA-Series Manual & Electric Actuators

Instructions

These instructions provide information about LA-Series Actuators. They are for use by personnel who are responsible for installation, operation and maintenance of LA-Series Actuators.

Safety Messages

All safety messages in the instructions are flagged with an exclamation symbol and the word Caution, Warning or Danger. These messages indicate procedures that must be followed exactly to avoid equipment damage, personal injury or death.

Safety label(s) on the product indicate hazards that can cause equipment damage, personal injury or death. If a safety label becomes difficult to see or read, or if a label has been removed, please contact DeZURIK for replacement label(s).



WARNING!

Personnel involved in the installation or maintenance of valves should be constantly alert to potential emission of pipeline material and take appropriate safety precautions. Always wear suitable protection when dealing with hazardous pipeline materials. Handle valves, which have been removed from service with suitable protection for any potential pipeline material in the valve.

Inspection

Your LA-Series Actuator has been packaged to provide protection during shipment, however, it can be damaged in transport. Carefully inspect the unit for damage upon arrival and file a claim with the carrier if damage is apparent.

Parts

Recommended spare parts are listed on the assembly drawing. These parts should be stocked to minimize downtime.

Order parts from your DeZURIK sales representative, or directly from DeZURIK. When ordering parts, please include the 7-digit part number and 4-digit revision number (example: **9999999R000**) located on the data plate attached to the valve assembly. Also include the part name, the assembly drawing number, the balloon number and the quantity stated on the assembly drawing.

DeZURIK Service

DeZURIK service personnel are available to install, maintain and repair all DeZURIK products. DeZURIK also offers customized training programs and consultation services.

For more information, contact your local DeZURIK sales representative or visit our website at www.dezurik.com.

Table of Contents

Description ----- 4
Required Tools ----- 4
Lubrication ----- 4
Spare Parts ----- 5
Drawings ----- 5
Adjusting Stops ----- 7
Disassembly and Removal ----- 7
Reassembly and Installation ----- 8
Setting Position Stops ----- 9
Troubleshooting ----- 9

DeZURIK

LA-Series Manual & Electric Actuators

Description

The LA-Series Actuator has a fully-enclosed compound link mechanism that is available in weatherproof or buriable models with internally adjustable stops.

The actuator is sized for the valve and shutoff pressure specified. Consult the factory for sizing information if the actuator is used for other applications.

The actuator conforms to the applicable requirements of ANSI/AWWA Standard C504.

Manual Operation

The manually operated actuator can be driven by a handwheel, chainwheel or a 2-inch nut. It is also available with a 2:1 spur gear drive. The actuator is designed for a 450-foot-pound input against the stops (without the spur gear), and 300 foot pounds with the spur gear.

Clockwise rotation of the actuator input shaft closes the valve. The number of actuator turns required to move the valve the 90 degrees from one position to the other is as follows:

MODEL	W/O Spur Gear	With Spur Gear
LA-4	34 turns	68 turns
LA-6	50 turns	100 turns
LA-10	84 turns	168 turns

Electric Operation

The motor-driven actuator has a keyed input shaft and is available with or without the spur gear drive.

Required Tools

The actuator is assembled with SAE fasteners. Tools required for disassembly, assembly and adjustment include a set of combination wrenches, a flat-tipped screwdriver, Allen wrenches, a pin punch, a file and a hammer.

Lubrication

The actuator does not require lubrication for routine maintenance. If the actuator is disassembled, however, lubricate all of the bearing, sealing and threaded surfaces of the components listed below with EXXON Unirex EP 2 Premium lubricant (**recommended**) or Petro-Canada Precision XL EP 2 (alternate) during assembly. See Figures 1 and 2 for parts location.

- Actuator input shaft, O-ring and bearings
- Input shaft threads
- Collars
- Both stop nuts
- Inner thrust washers, both sides
- Guide nuts
- Guide bars
- Yoke nut
- Bearing and O-ring where valve shaft enters actuator housing

After the actuator is fully assembled, apply a layer of lubricant approximately 1/2" thick to the above surfaces that are accessible inside the housing. For buried service, continue to apply lubricant until the housing is 90% filled.

Spare Parts

- Recommended spare parts are listed below. Replace worn parts as described below.
- Housing bearing (B2)
- Thrust washers (B15, B16)
- O-ring for valve shaft (B11)
- O-rings for actuator shaft (B12, B49)
- Bearing (B17)
- Seal (B28)

Drawings

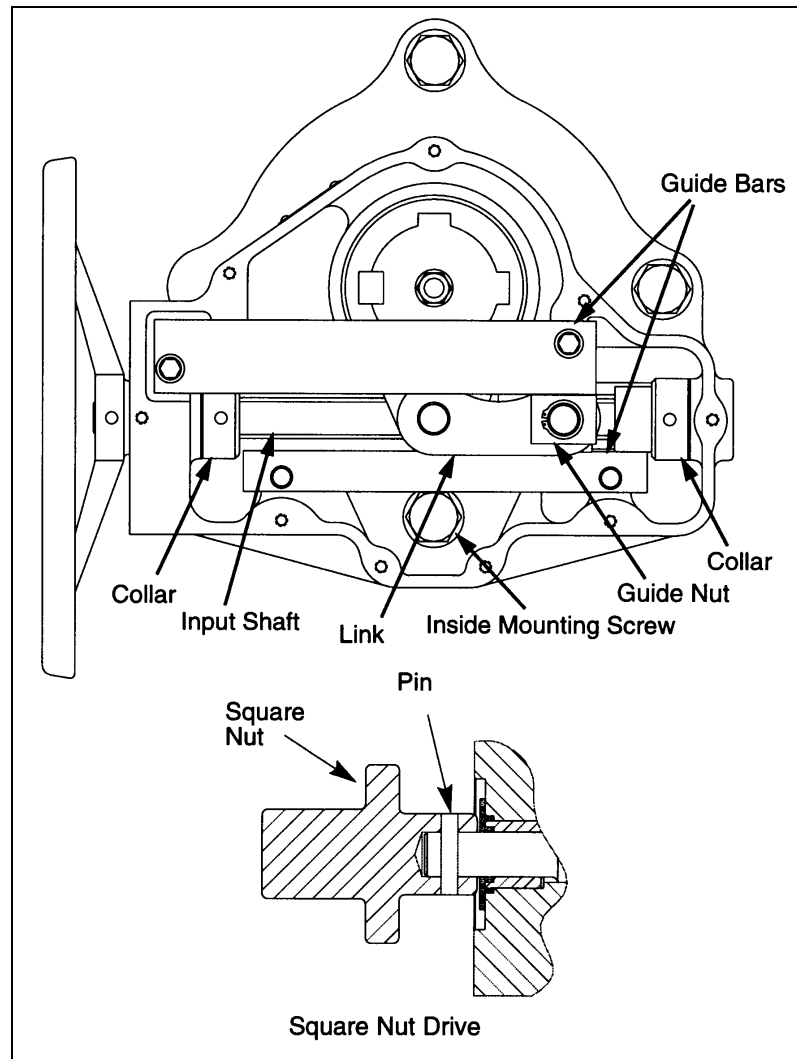

Figure 1—Actuator Top View

Drawings (Continued)

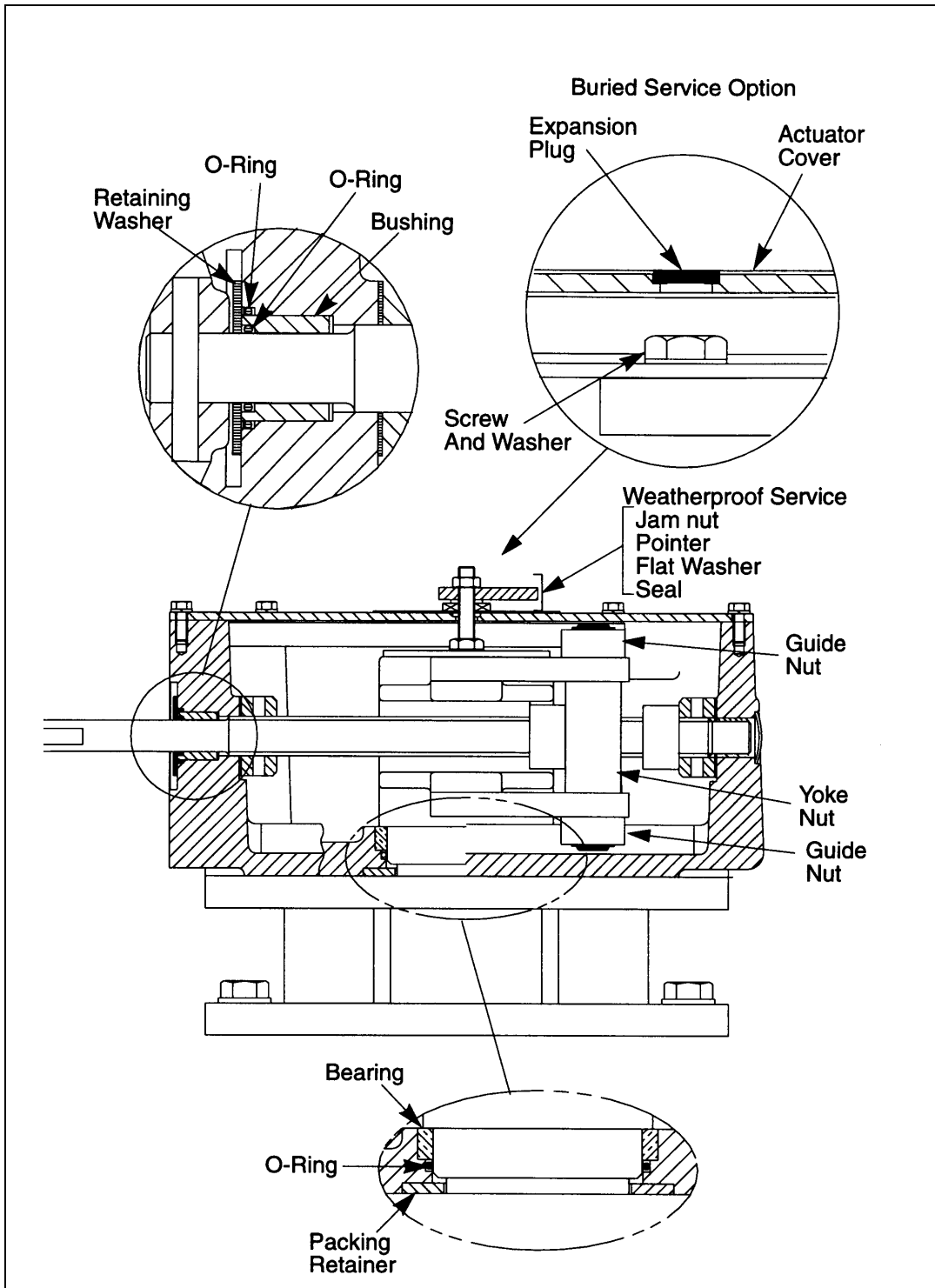

Figure 2—Actuator Side View

Adjusting Stops

The adjustable stops prevent the actuator from going beyond the open and closed positions of the valve. The stops are preset and do not require further adjustment. If the actuator is disassembled, however, the stops may require readjustment as described in the SETTING STOPS sections of this manual.

Disassembly and Removal

1. Relieve the pressure and flow in the pipeline.



WARNING!

This actuator retains the stem packing in the valve. The actuator and packing could be forcibly ejected and could cause personal injury if the actuator mounting screws are removed with pressure in the valve. Relieve pressure in the valve before removing the actuator.

2. Close the valve.
3. If the actuator is powered, disconnect and lock out the pneumatic, hydraulic, or electrical power to prevent accidental operation of the actuator.



WARNING!

Moving parts from accidental operation of power actuator can cause personal injury or equipment damage. Disconnect and lock out power to actuator before servicing.

4. If the actuator has a pointer, remove the jam nut (B33), pointer (B29), flat washer (B91) and seal (B28).
5. Remove the cover screws (B19), washers (B20) and cover (B4) from actuator.
6. Drive the pins (B14) out of the collars (B13). The pins can be driven straight through toward the bottom of the housing.
7. Remove the inner (B25) and outer (B24) guide bars.
8. Unscrew the actuator input shaft (B10) from the collars (B13), the stop nuts (B27), and the yoke nut (B7).
9. Remove the shaft from the actuator housing.
10. Remove all of the remaining shaft components from the housing.
11. From the valve shaft, remove the yoke (B3), yoke nut and link assembly. Keep the drive key with the yoke.
12. Remove the actuator mounting screws (B41 or B42), and remove the actuator housing from the valve.
13. From yoke nut and link assembly, remove retaining rings (B9), guide nuts (B8) and links (B6).

Reassembly and Installation

1. Clean all parts and remove old sealant from the actuator cover.
2. Restore the key and keyway in the valve shaft to original condition.
3. If the yoke bearing (B2) in the bottom of the housing is worn, replace it.
4. Install a new O-ring (B11) outside the yoke bearing.
5. On the outside of the bottom of the actuator housing, run a bead of sealant around the bolt hole that goes into the inside of the housing.
6. Set actuator housing on valve. Make sure relief groove on bottom of actuator is open.
7. Insert the screws (three on models LA-4 and LA-6, four on model LA-10) that fasten actuator housing to the valve.
8. Lubricate bearing surfaces of yoke nut and links and the bearing surfaces inside actuator housing.
9. Partially assemble yoke nut, one guide nut (not used on LA-10), link and snap ring (one side only).
10. Install partially assembled yoke nut assembly on yoke. On the model LA-4 actuator make sure the curved side of the link faces the correct side of the yoke (see drawing).
11. Install second link, guide nut and retaining ring on yoke and yoke nut.
12. Place yoke and nut assembly into housing with machined end of yoke down.
13. Inspect the holes near the ends of the actuator shaft and remove any burrs made while the pins were being removed during disassembly.
14. Insert shaft part way into housing, small end first.
15. Lubricate both sides of thrust bearing, then place on shaft with metal surface of bearing facing toward the actuator housing.
16. Place a collar onto the shaft with the chamfered end toward the middle of the actuator.
17. Thread a stop nut onto the shaft.
18. Thread the shaft through the yoke nut. On models LA-4 and LA-6, the machined side of the yoke nut faces away from the valve shaft.
19. Thread a second stop nut onto the shaft.
20. Place the second collar on the shaft with the chamfered end toward the middle of the actuator.
21. Install the second thrust bearing on the shaft.
22. Place shims on shaft. All shims are installed between the actuator housing and the thrust washer that is farthest from the input side of the actuator.
23. At both ends of the actuator shaft, align the holes in the collars with the holes in the shaft.
24. Drive a pin into each collar.
25. With both actuator and valve in fully closed position, make minor adjustments to align one of the keyways in the actuator yoke with the single keyway in the valve shaft.
26. Drive the key between the valve shaft and the actuator yoke until it is flush with the top of the shaft. Do not "mushroom" the end of the key.

Reassembly and Installation *(Continued)*

27. Center punch the end of the valve shaft on each side of the key to retain key in keyway.
28. Complete the assembly by following steps 2 -12 in the SETTING STOPS section of this manual.

Setting Stops

1. Remove inner and outer guide bars if present.
2. Thread stop nuts along shaft to get desired open and closed positions of valve. To get longer stroke, move stop nuts toward middle of actuator.
3. Install inner and outer guide bars, and start screws into actuator. Leave screws loose.
4. Operate valve to full open and closed positions to check locations of stop nuts.
5. If open or closed position is not satisfactory, follow steps 1 through 4 above. If open and closed positions are both satisfactory, go to next step.
6. Tighten screws for guide bars as follows: while using a screwdriver to hold the guide bars away from the actuator shaft, tighten the screws.
7. Move the actuator to the closed position.
8. Clean the mating surfaces on the actuator housing and cover.
9. Using RTV or another silicone based sealant, form a gasket on the mating surface of the actuator housing.
10. Install the actuator cover.
11. **WITH POSITION INDICATOR:** If the actuator has a pointer, install the seal, flat washer, pointer (pointing to "CLOSED") and jam nut in that order.
WITHOUT POSITION INDICATOR: If the actuator does not have a pointer, (Buried Service): Install compression plug in hole in middle of actuator cover.
12. If the actuator is powered, reconnect power to the actuator.

Troubleshooting

Symptom	Possible Cause	Corrective Action
Actuator closes to wrong position	Closed position stop is set incorrectly	Adjust closed position stop
Actuator opens to wrong position	Open position stop is set incorrectly	Adjust open position stop
Actuator won't move to closed position stop	Obstruction in valve is preventing closure	Remove obstruction
Motor turns but actuator does not turn	Key in motor drive is sheared	Remove drive from actuator and replace key
Actuator turns but valve does not turn	Key that connects yoke to valve shaft is sheared	Replace key in valve shaft inside actuator housing
Motor turns wrong way	Motor wired incorrectly	See motor wiring diagram
Valve turns wrong way	Yoke-to-shaft key in 90 degrees off	Disengage actuator yoke from valve shaft. Index yoke 90 degrees. Reengage.