



more sensors, more solutions

A-GAGE[®] High-Resolution MINI-ARRAY[®] Instruction Manual

For controllers with 2 analog and 2 discrete outputs

High-Resolution MINI-ARRAY Features

- Excels at high-speed, precise process monitoring and inspection applications
- A comprehensive combination of scanning modes and outputs:
 - 10 measurement (“Scan Analysis”) modes
 - 3 scanning methods
 - Beam blanking
 - Selectable continuous, gated or host-controlled scan initiation
 - Programmable hysteresis for high and low limits
 - Serial communication options
- Storable scanning programs eliminate reprogramming for repeated applications
- Non-volatile memory stores alignment settings
- All models with both Analog and Discrete outputs
- Analog output Null setting
- Low cost, compared with similar systems
- Precision sensors have a 380 mm to 1.8 m (15" to 6') working range
- Wide field of view, easily aligned
- Alignment routine equalizes gain of each beam for reliable 2.5 mm (0.10") object detection throughout the array
- Host computer or PLC may be used to initiate scans and/or process scan data
- Unique addresses for up to 15 control modules on one EIA-485 Party Line

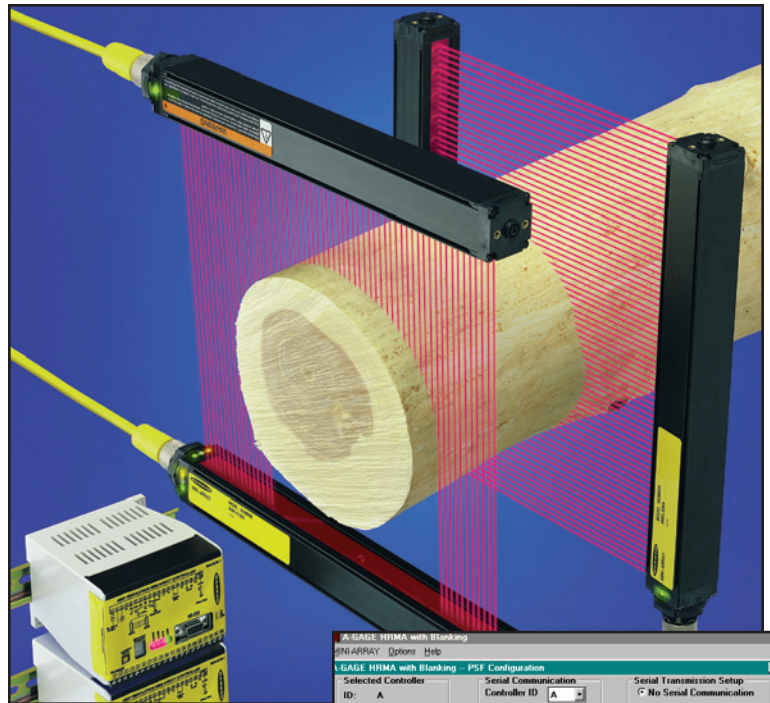

WARNING . . . Not To Be Used for Personnel Protection

These sensors do NOT include the self-checking redundant circuitry necessary to allow their use in personnel safety applications. A sensor failure or malfunction can cause either an energized or de-energized output condition. Consult your current Banner Safety Products catalog for safety products which meet OSHA, ANSI and IEC standards for personnel protection.



more sensors, more solutions

9714 10th Avenue North • Minneapolis, MN 55441
Phone: 763.544.3164 • Fax: 763.544.3213
Email: sensors@baneng.com



1. System Description	4
1.1 System Components	4
1.2 System Features	6
1.3 Typical Applications	7
2. Specifications	8
2.1 Emitter and Receiver Specifications	8
2.2 Control Module Specifications	10
3. Installation and Mechanical Alignment	12
3.1 Emitter and Receiver Mounting	12
3.2 Control Module Mounting	13
3.3 Hookups	14
3.3.1 Emitter and Receiver Hookups	15
3.3.2 Inputs	15
3.3.3 Outputs	15
4. Software Installation	16
5. Control Module Configuration	17
5.1 Communications Setup	17
5.1.1 Ping Routine	17
5.1.2 Factory Settings	18
5.2 System Alignment	18
5.2.1 Push-button Alignment Routine	18
5.2.2 Software Alignment Routine	19
5.2.3 Blanking	20
5.3 Programming Control Module Response	21
5.3.1 Selected Controller and Serial Connection	23
5.3.2 Control Mode Selection	23
5.3.3 Scanning Method	24
5.3.4 Scan Analysis Mode Selection	26
5.3.5 Analog Output Configuration (Analysis Mode Assignment)	26
5.3.6 Zero Value	27
5.3.7 Discrete Output Configuration (Analysis Mode Assignment)	28
5.4 Serial Communication with a Host Controller	29
5.4.1 Serial Data Transmission	29
5.4.2 Transmission Type	29
5.4.3 Serial Options	30
5.5 Transfer of PSF to the Control Module	30
5.5.1 Saving and Recalling PSF Files	31
5.5.2 PSF Output Analysis	31
5.5.3 Quit and Exit	31
6. System Diagnostics	32
6.1 Diagnostics Indicators	32
6.2 Diagnostics Routine	33
Appendix A: Data Transmission	34
A.1 Host Mode Command String	34
A.2 Serial Data Format and Header String	34
A.2.1 ASCII Format Data Transmission	35
A.2.2 Binary Format Data Transmission	35
A.3 Max Measure Mode Command String	36
Appendix B: Glossary	38

System Description

1. System Description

The A-GAGE[®] High-Resolution MINI-ARRAY[®] measuring light screen is ideal for applications such as on-the-fly product sizing and profiling, edge-guiding and center-guiding, loop tensioning control, hole detection, parts counting and similar uses.

1.1 System Components

A typical A-GAGE High-Resolution MINI-ARRAY System has five components: a high-resolution emitter/receiver pair, each with quick-disconnect (QD) connectors; one of four compact control modules; and quick-disconnect cables to connect them. Software is included to interface any PC-compatible computer (running Windows[®] X, Vista, or 7) with the control module for System configuration. A host computer or PLC may be used to control and/or receive input from the System.

Sensors are available in 12 array lengths from 163 mm to 1951 mm (6.4" to 76.8"), in 163 mm (6.4") increments, as listed in the table on page 5. The emitter has two columns of infrared LEDs spaced 5 mm (0.2") apart. The columns are separated by 7.5 mm (0.3") and are staggered from each other by 2.5 mm (0.1"). The receiver is configured opposite to the emitter, with the identical length and beam spacing. This high-resolution sensor pair is capable of detecting a 12.7-mm long by 2.54-mm diameter (0.5" by 0.1" dia.) cylindrical rod (held perpendicular to the sensor). The sensors have a wide field of view and are easily aligned, with a working range of 380 mm to 1.8 m (15" to 6').

Each of the four versatile microcontroller-based control modules are configured using a PC-compatible computer running Windows XP, Vista, or 7, and the supplied software, via the built-in RS-232 interface.

Emitter and Receiver Models

Emitter/Receiver Model	Array Length Y*	Total Beams
MAHE6A Emitter MAHR6A Receiver	163 mm (6.4")	64
MAHE13A Emitter MAHR13A Receiver	325 mm (12.8")	128
MAHE19A Emitter MAHR19A Receiver	488 mm (19.2")	192
MAHE26A Emitter MAHR26A Receiver	650 mm (25.6")	256
MAHE32A Emitter MAHR32A Receiver	813 mm (32.0")	320
MAHE38A Emitter MAHR38A Receiver	975 mm (38.4")	384
MAHE45A Emitter MAHR45A Receiver	1138 mm (44.8")	448
MAHE51A Emitter MAHR51A Receiver	1300 mm (51.2")	512
MAHE58A Emitter MAHR58A Receiver	1463 mm (57.6")	576
MAHE64A Emitter MAHR64A Receiver	1626 mm (64.0")	640
MAHE70A Emitter MAHR70A Receiver	1788 mm (70.4")	704
MAHE77A Emitter MAHR77A Receiver	1951 mm (76.8")	768

High-Resolution Emitter



High-Resolution Receiver



Configure and monitor the System with the supplied software and any PC-compatible computer (running Windows® XP, Vista, or 7), via an RS-232 cable.

Quick-Disconnect Cables

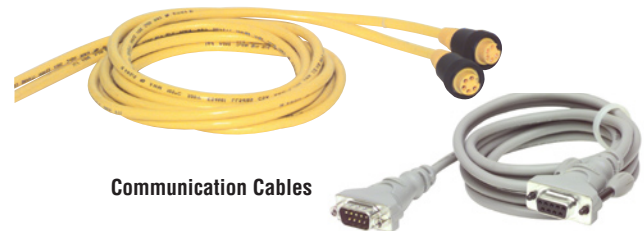

Communication Cables



DIN-Rail Mountable Control Module

Control Module Models

Controller Model	Solid-State Discrete Outputs	Analog Outputs
MAHCVP-1	2 PNP	(2) 0-10V Sourcing
MAHCVN-1	2 NPN	(2) 0-10V Sourcing
MAHCIP-1	2 PNP	(2) 4-20 mA Sinking
MAHCIN-1	2 NPN	(2) 4-20 mA Sinking

Cables

Cable Model	Description
Sensor Cables	
QDC-515C	4.6 m (15') Cable, straight QD connector
QDC-525C	7.6 m (25') Cable, straight QD connector
QDC-550C	15.2 m (50') Cable, straight QD connector
Communication Cables	
MASC	2 m (6.5') DB9, straight RS-232 cable

Figure 1-1. A-GAGE High-Resolution MINI-ARRAY System components

System Description

1.2 System Features

Built-in features simplify the operation of the A-GAGE High-Resolution MINI-ARRAY system. High-resolution emitters and receivers, available in 12 lengths, feature two closely spaced columns of beams to provide a precise, high-resolution light screen for exacting applications. The Alignment routine automatically equalizes the excess gain of each beam for reliable 2.5-mm (0.10") object detection throughout the array and stores this data in non-volatile memory. The Alignment routine need not be performed again unless the sensing application changes, or if the emitter and/or receiver is moved. Programmable beam blanking accommodates machine components or other fixtures that must remain in or move through the light screen. Blanking may be set automatically as part of the initial setup, or by using the included configuration software.

Built-in diagnostic programming and easy-to-see indicators on the sensors and the control module make alignment and troubleshooting easy (Figure 1-2). The emitter has a red LED that signals proper operation. The receiver has three bright LEDs: green signals that the sensors are properly aligned; yellow signals marginal alignment; and red signals misalignment or a blocked condition. The control module has four status indicators: 3 red LEDs signal discrete output #1 conducting (see section 5.3.5 for more information on outputs), Alarm output (discrete output #2) conducting, and gate signal received; a green LED signals that the sensors are properly aligned. A segmented LED Diagnostics Indicator provides detailed system status using single-digit codes; a "period" in the indicator window indicates the presence of blanking. A key to the diagnostics codes is printed on the side of the control module for simplified troubleshooting.

The A-GAGE High-Resolution MINI-ARRAY System provides a wide selection of sensing and output options, including: measurement ("scan analysis") modes and scanning methods that can determine the target object's location, overall size, total height or total width. Scanning may be continuous or controlled by a host process controller or a gate sensor. Up to 15 systems may be networked.

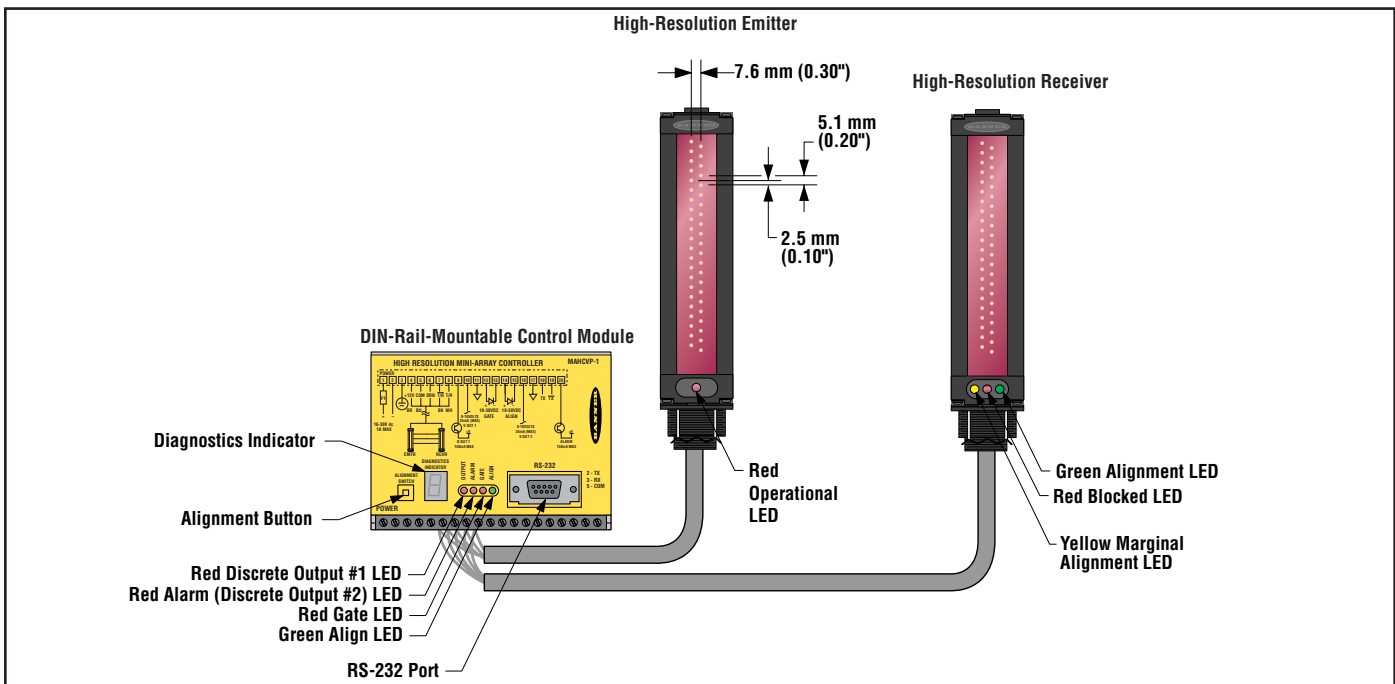

Figure 1-2. A-GAGE High-Resolution MINI-ARRAY System features

Supplied System Software

The supplied HRMA software program, used to configure each System control module, may be run on any PC-compatible computer running Windows[®] XP, Vista, or 7. The menu-driven program walks the user through the many scanning and output options. After the desired options are selected, the user can save the combination of selections in a Parameter Setup File (PSF), and store it in the control module's non-volatile memory. Any number of PSFs may be stored in the system configuration computer and recalled as needed.

The software also provides alignment and diagnostics routines. An Alignment screen displays the individual status of each beam in the light screen, as well as the total number of beams in the System, and totals of beams blocked, made and blanked. Built-in system diagnostics can be used to assess emitter and receiver hardware errors.

1.3 Typical Applications

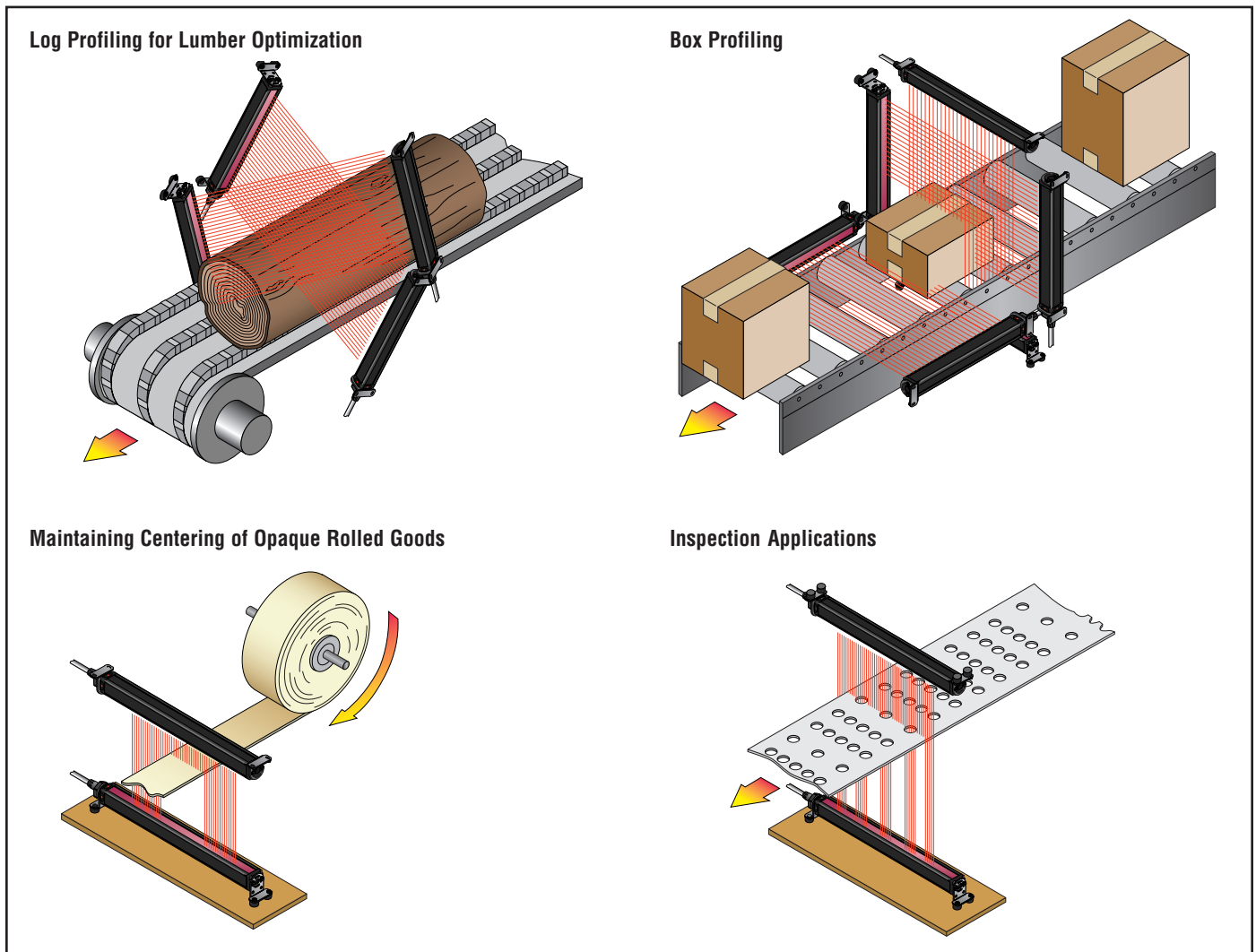



Figure 1-3. Typical applications for the A-GAGE High-Resolution MINI-ARRAY System

Specifications

2. Specifications

2.1 Emitter and Receiver Specifications

Emitter/Receiver Range	380 mm to 1.8 m (15" to 6')
Minimum Object Sensitivity	2.5 mm (0.1")
Sensor Scan Time	1.8 milliseconds to 58.4 milliseconds, depending on scanning method and sensor length; see Section 5.3.3 for detailed information
Power Requirements	12V dc \pm 2%, supplied by controller
Connections	Sensors connect to controller using two 5-conductor quick-disconnect cables (one each for emitter and receiver), ordered separately. See page 5 for available lengths. Use only Banner cables, which incorporate a "twisted pair" for noise immunity. Cables measure 8.1 mm (0.32") in diameter and are shielded and PVC-jacketed. Conductors are 20 gauge (0.9 mm). Emitter and receiver cables may not exceed 75 m (250') long, each.
Status Indicators	Emitter: Red LED lights to indicate proper emitter operation Receiver: Green indicates sensors aligned Yellow indicates marginal alignment of one or more beams Red indicates sensors misaligned or one or more beam(s) blocked
Construction	Aluminum, with black anodized finish; acrylic lens cover
Environmental Rating	NEMA 4, 13 (IP65)
Operating Conditions	Temperature: 0° to +50°C (+32° to 122°F) Maximum relative humidity: 95% at 50°C (non-condensing)
Certifications	

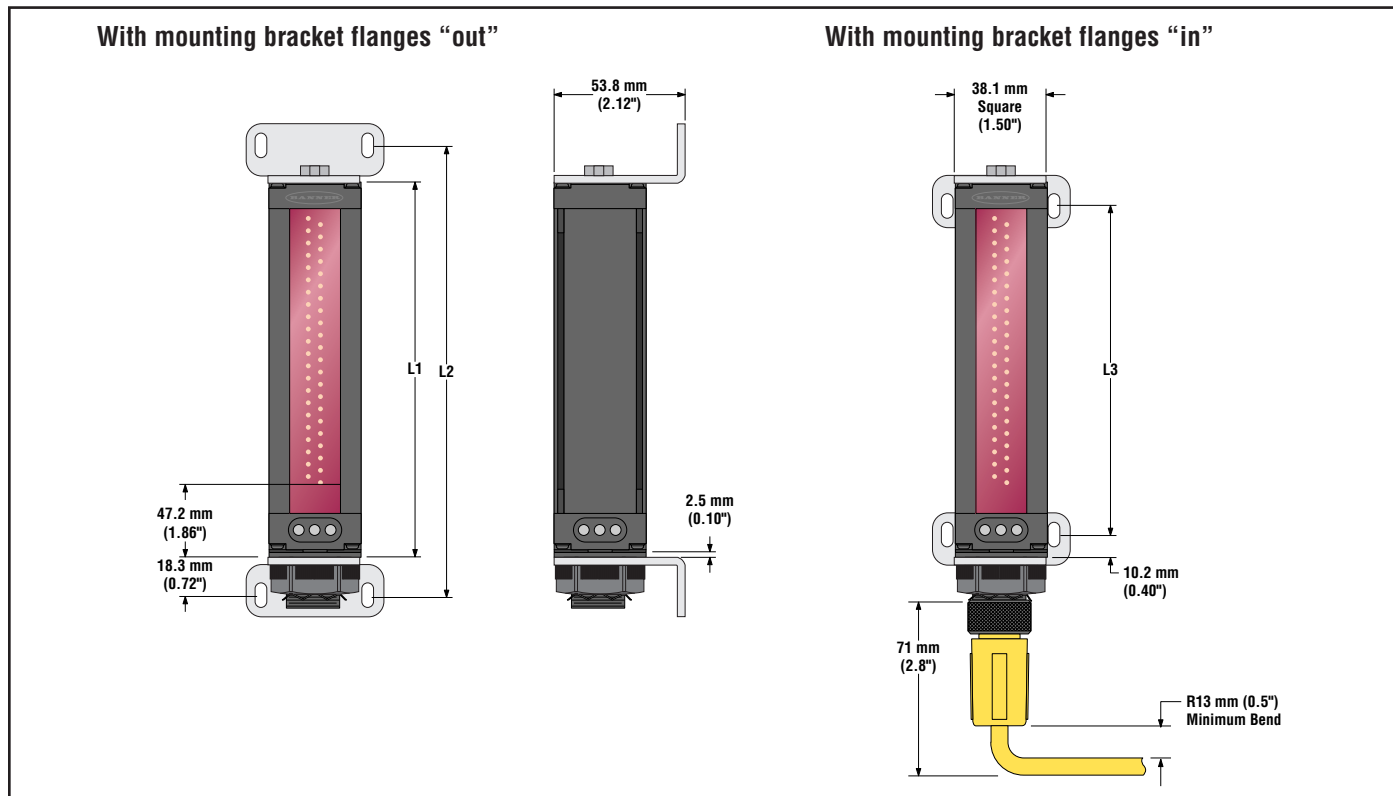



Figure 2-1. Emitter and receiver dimensions

Emitter/Receiver Model	Housing Length		Distance Between Bracket Holes	
	L1	L2	L3	
MAHE6A Emitter MAHR6A Receiver	236 mm (9.3")	268 mm (10.5")	211 mm (8.3")	
MAHE13A Emitter MAHR13A Receiver	399 mm (15.7")	430 mm (16.9")	373 mm (14.7")	
MAHE19A Emitter MAHR19A Receiver	561 mm (22.1")	593 mm (23.3")	536 mm (21.1")	
MAHE26A Emitter MAHR26A Receiver	724 mm (28.5")	756 mm (29.7")	699 mm (27.5")	
MAHE32A Emitter MAHR32A Receiver	887 mm (34.9")	918 mm (36.2")	861 mm (33.9")	
MAHE38A Emitter MAHR38A Receiver	1049 mm (41.3")	1081 mm (42.6")	1024 mm (40.3")	
MAHE45A Emitter MAHR45A Receiver	1215 mm (47.8")	1246 mm (49.1")	1189 mm (46.8")	
MAHE51A Emitter MAHR51A Receiver	1377 mm (54.2")	1409 mm (55.5")	1352 mm (53.2")	
MAHE58A Emitter MAHR58A Receiver	1540 mm (60.6")	1572 mm (61.9")	1515 mm (59.6")	
MAHE64A Emitter MAHR64A Receiver	1703 mm (67.0")	1734 mm (68.3")	1677 mm (66.0")	
MAHE70A Emitter MAHR70A Receiver	1865 mm (73.4")	1897 mm (74.7")	1840 mm (72.4")	
MAHE77A Emitter MAHR77A Receiver	2028 mm (79.8")	2060 mm (81.1")	2003 mm (78.8")	

Specifications

2.2 Control Module Specifications

Output Configuration	MAHCVP-1: Two PNP discrete (switched), two 0-10V voltage sourcing MAHCVN-1: Two NPN discrete (switched), two 0-10V voltage sourcing MAHCIP-1: Two PNP discrete (switched), two 4-20 mA current sinking MAHCIN-1: Two NPN discrete (switched), two 4-20 mA current sinking
Power Requirements	16 to 30V dc @ 1.0 A (typical: 0.5 A @ 16V dc)
Inputs	Sensor input: Emitter and receiver wire in parallel to five terminals. Gate input: Optically isolated, requires 10 to 30V dc (7.5k Ω impedance) for gate signal Remote alignment input: Optically isolated, requires 10 to 30V dc (7.5k Ω impedance) for alignment sequence signal
Discrete (Switched) Outputs	NPN outputs: Open collector NPN transistor rated at 30V dc max., 150 mA max. PNP outputs: Open collector PNP transistor rated at 30V dc max., 150 mA max. All discrete outputs: OFF-state leakage current: < 10 μ A @ 30V dc ON-state saturation voltage: < 1V @ 10 mA and < 1.5V @ 150 mA
Analog Outputs	Voltage-sourcing outputs: 0 to 10V dc (25 mA current limit) Current-sinking outputs: 4 to 20 mA (16 to 30V dc input) Resolution: Span/Number of sensing channels Linearity: 0.1% of full scale Temperature variation: 0.01% of full scale per $^{\circ}$ C
Serial Data Outputs	RS-232 or RS-485 interface. (Up to 15 control modules may be given unique addresses on one RS-485 party line.) ASCII or binary data format 9600, 19.2K, or 38.4K baud rate 8 data bits, 1 stop bit, and even, odd, or no parity
System Programming	Via RS-232 interface to PC-compatible computer running Windows [®] XP, Vista, or 7 and using software supplied with each control module.
Status Indicators	Output 1 (red): Lights to indicate Discrete Output #1 is active Alarm (red): Lights to indicate Discrete Output #2 is active Gate (red): Lights to indicate GATE input is active Align (green): Lights to indicate emitter and receiver are aligned Diagnostics indicator: (Key on controller side label) Identifies System errors and status
Construction	Polycarbonate housing; mounts to flat surface or directly onto 35-mm DIN rail
Environmental Rating	Control Module: NEMA 1, IEC IP20 Emitter/Receiver: NEMA 4, 13; IEC IP65
Operating Conditions	Temperature: 0 $^{\circ}$ to +50 $^{\circ}$ C (+32 $^{\circ}$ to 122 $^{\circ}$ F) Maximum relative humidity: 95% @ 50 $^{\circ}$ C (non-condensing)
Certifications	

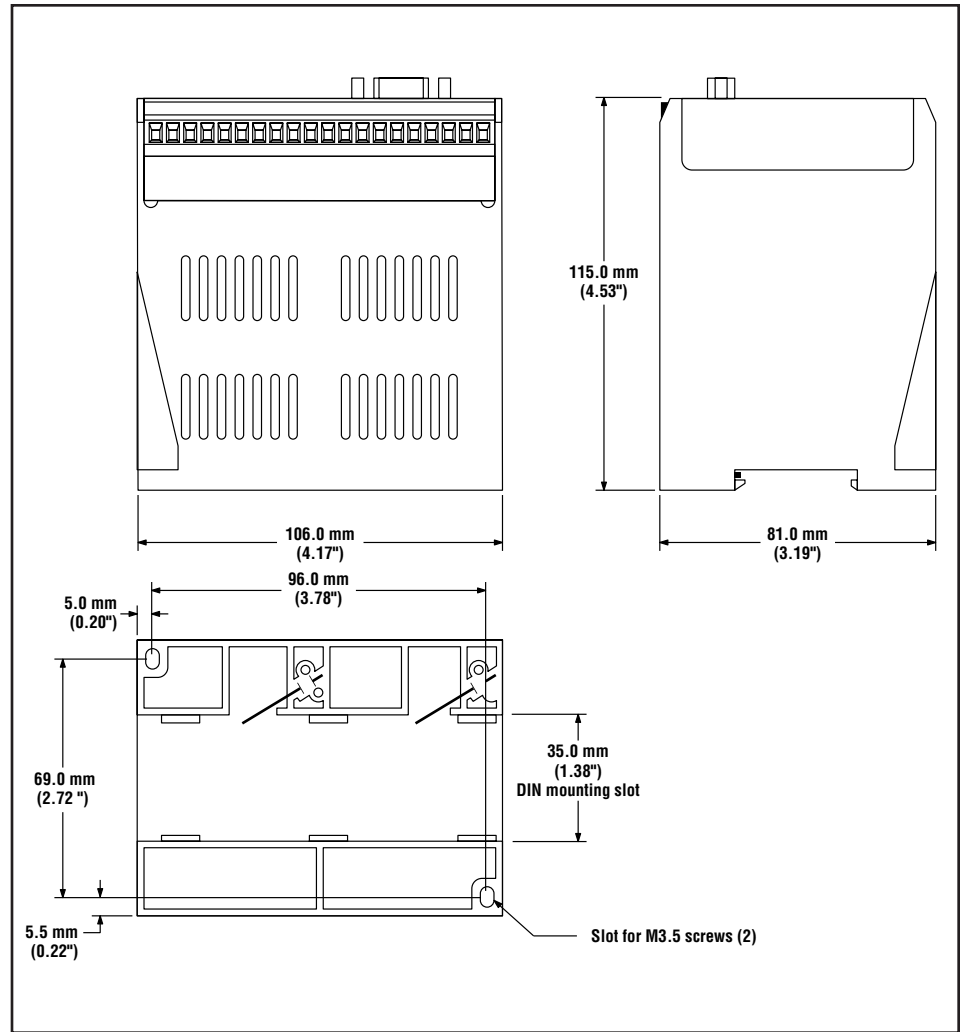

Figure 2-2. Control module dimensions

3. Installation and Mechanical Alignment

3.1 Emitter and Receiver Mounting

Banner MINI-ARRAY emitters and receivers are small, lightweight, and easy to handle during mounting. The mounting brackets (supplied) allow $\pm 30^\circ$ rotation.

From a common point of reference, make measurements to locate the emitter and receiver in the same plane with their midpoints directly opposite each other. Mount the emitter and receiver brackets using the vibration isolators and M4 Keps nuts (all supplied). See Figure 3-1. Standard M4 or #8-32 bolts may be substituted (and the vibration isolators eliminated) in situations where the emitter and receiver are not subjected to shock or vibration forces. While the internal circuits of the emitter and receiver are able to withstand heavy impulse forces, the vibration isolators dampen impulse forces and prevent possible damage due to resonant vibration of the emitter or receiver assembly.

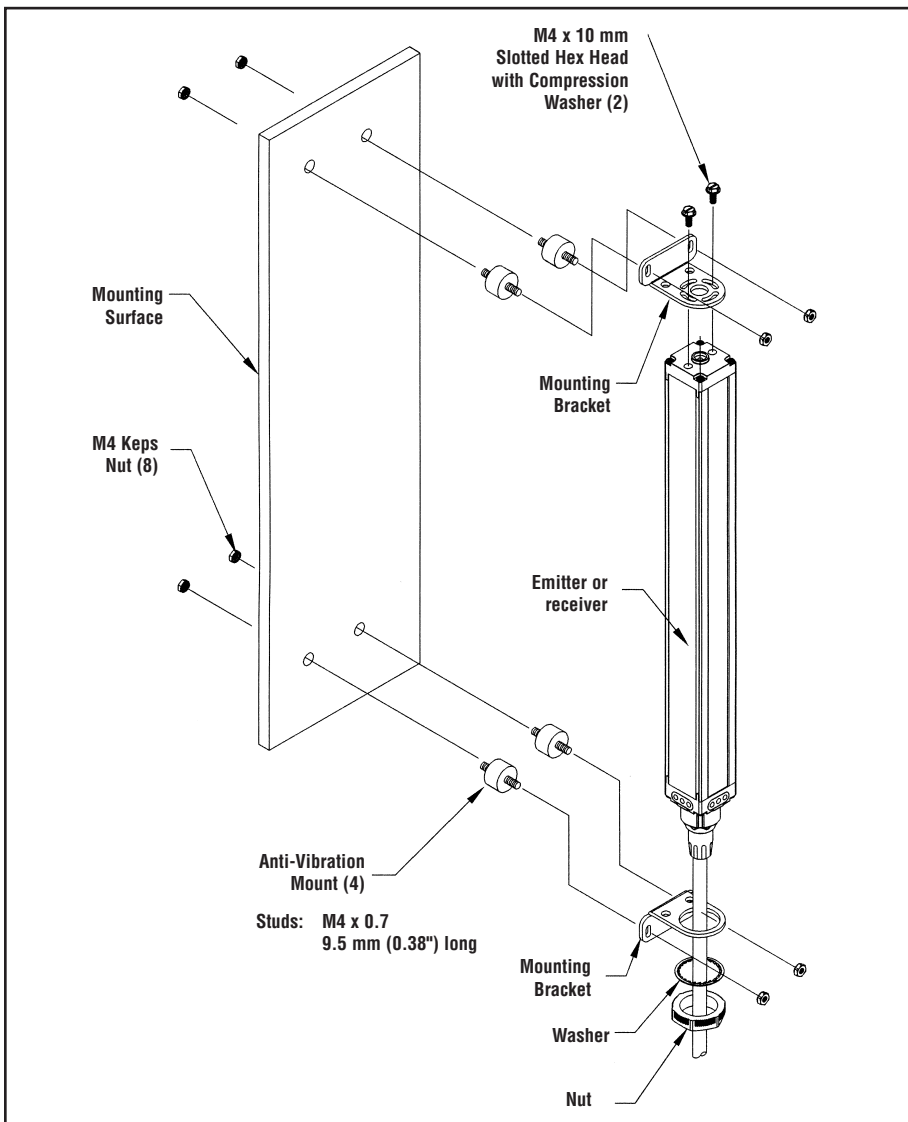

Figure 3-1. A-GAGE High-Resolution MINI-ARRAY emitter and receiver mounting hardware

Mount the emitter and receiver in their brackets and position the red lenses of the two units directly facing each other. The connector ends of both sensors must point in the same direction. Measure from one or more reference planes (e.g. the building floor) to the same point(s) on the emitter and receiver to verify their mechanical alignment. If the sensors are positioned exactly vertical or horizontal to the floor, a carpenter's level is useful for checking alignment. A straightedge or a string extended between the sensors also helps with positioning. Also check "by eye" for line-of-sight alignment. Make any necessary final mechanical adjustments, and hand-tighten the bracket hardware. See Section 6 for information on alignment indicators and Section 5 for information on the use of the alignment software which is supplied with the controller.

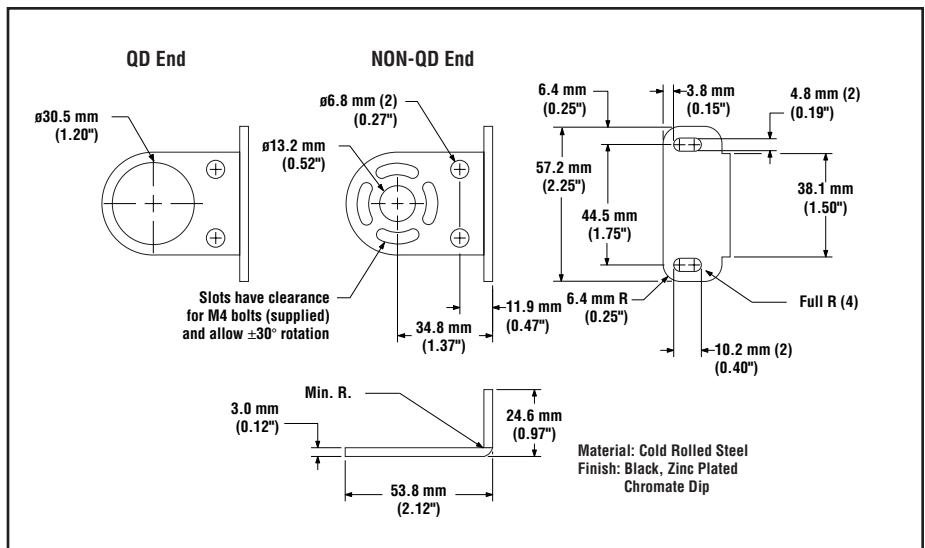

Figure 3-2. A-GAGE High-Resolution MINI-ARRAY emitter and receiver mounting bracket dimensions

3.2 Control Module Mounting

The control module must be installed inside an enclosure which has a NEMA (or IEC) rating suitable for the operating environment.

Mounting dimensions for the controller are shown in Figure 2-2, on page 11. The control module is supplied with M3.5 hardware for direct mounting to a surface, or the module may be mounted onto standard 35 mm DIN rail.

Installation and Mechanical Alignment

3.3 Hookups

Refer to Figures 3-4, 3-5, 3-6, and 3-7 for the appropriate hookup information.

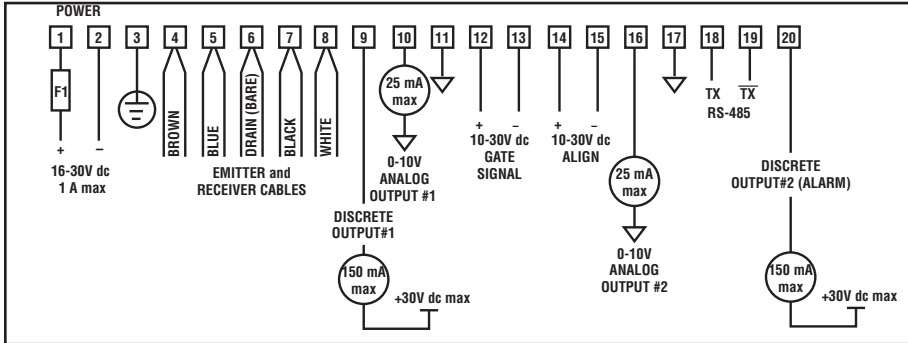

Figure 3-3. MAHCVN-1 hookup

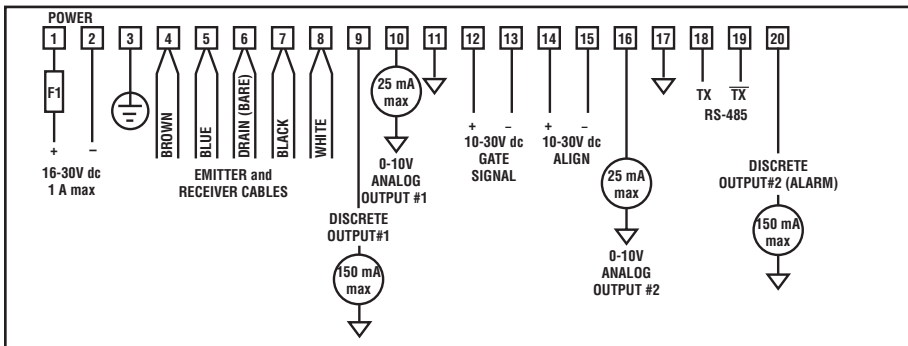

Figure 3-4. MAHCVP-1 hookup

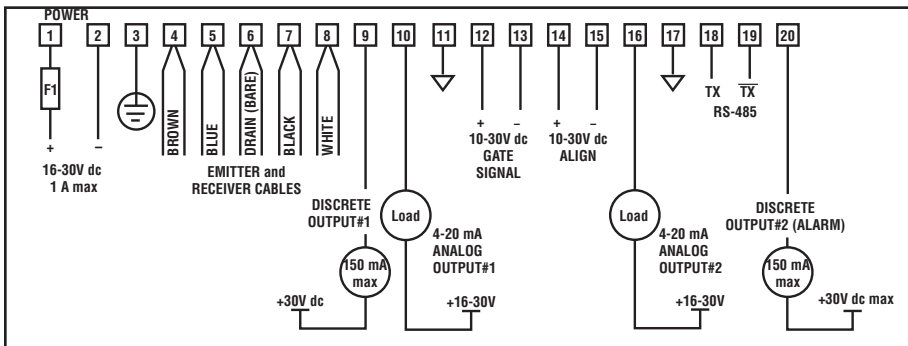

Figure 3-5. MAHCIN-1 hookup

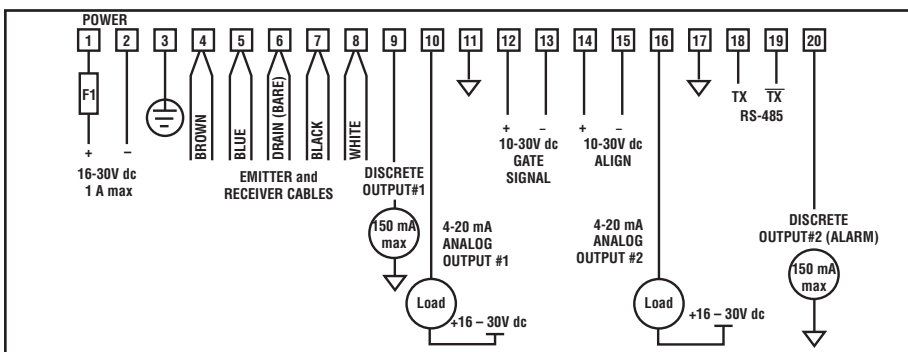

Figure 3-6. MAHCIP-1 hookup

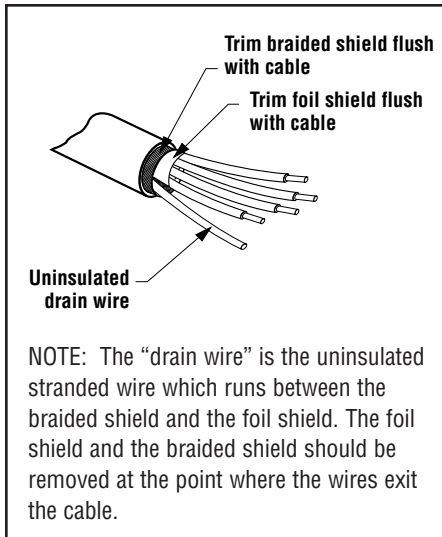

Figure 3-7. Emitter and receiver cable preparation

3.3.1 Emitter and Receiver Hookups

Emitters and receivers connect together in parallel to terminals #4 through #8 of the control module (identical for all control module models). See Figures 3-3, 3-4, 3-5, and 3-6 for wire color information.

3.3.2 Inputs

System Power: Connect a source of 16 to 30V dc, rated at 1 amp or greater, to control module terminals #1 (+) and #2 (-). Connect a good earth ground to terminal #3 to provide electrical and RF noise immunity to the System.

NOTE: Remove power before making other connections to the controller.

Gate Signal: A source of 10 to 30V dc switched to terminals #12(+) and #13(-) provides a gating input (if required). The gating voltage typically is switched by the open-collector output transistor of a dc sensing device. The gate signal controls scanning when one of four Gate options is selected in the Control Mode Selection menu of the PSF configuration routine (see Section 5.3.2).

Align: A source of 10 to 30V dc switched to terminals #14(+) and #15(-) provides a remote means of running the automatic alignment and blanking routines. The switch sequence is identical to the procedure described in Section 5.2.1 for the Alignment switch on the front of the control module.

3.3.3 Outputs

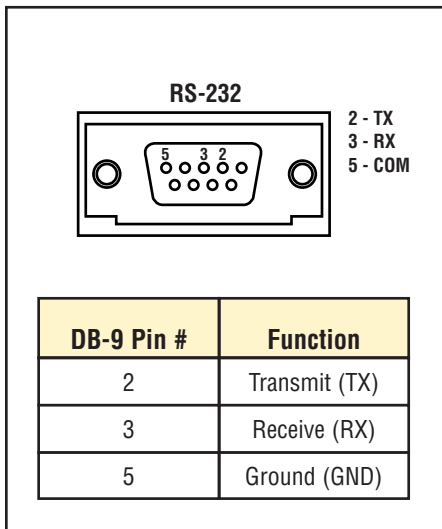

Figure 3-8. DB-9 connections between the control module and the PC

Control Module	Analog Outputs (Terminals #10 and 16)	Discrete Outputs* (Terminals #9 and 20)
MAHCVN-1 Figure 3-3	0 to 10V Sourcing 15 mA max.	NPN open-collector 30V dc max. 150 mA max.
MAHCVP-1 Figure 3-4	0 to 10V Sourcing 15 mA max.	PNP open-collector 30V dc max.
MAHCIN-1 Figure 3-5	4 to 20 mA Sinking 16 to 30V dc	NPN open-collector 30V dc max. 150 mA max.
MAHCIP-1 Figure 3-6	4 to 20 mA Sinking 16 to 30V dc	PNP open-collector 30V dc max. 150 mA max.

*NOTE: Discrete Output #2 is labeled “Alarm” on the control module.

Serial Communication

RS-232: All A-GAGE High-Resolution MINI-ARRAY Systems may communicate with a host computer or controller via RS-232 or RS-485 serial protocol. See Section 5.3.1 for selectable communications parameters. Prepare an RS-232 cable using a male DB-9 connector with connections as shown in Figure 3-8.

NOTE: DO NOT use a “null modem” RS-232 cable

RS-485: RS-485 serial port is located at terminals #18 (TX) and #19 (TX).

4. Software Installation

The High-Resolution MINI-ARRAY software CD includes an installation routine that quickly and easily loads the MINI-ARRAY configuration program into your computer. The High-Resolution MINI-ARRAY configuration program requires approximately 50 MB of hard disk space. Install as follows:

1. Use the Parameter Setup Software CD included with the controller, or download (www.bannerengineering.com) as required.
2. Insert the Software CD into the CD drive.
If the program does not auto-start, browse to your CD drive, click **Setup.exe**, then select **START**, then select **RUN**.
2. The **Welcome** dialog box will appear. Select **Next**, and follow the prompts in the dialog boxes as they appear.
4. The installation program then decompresses the files. A status dialog box monitors the progress of the installation.
5. An **Installation Completed** dialog box appears. Select **OK**. Reboot your computer for the changes to take effect.

After the software is installed, a **MINI-ARRAY shortcut icon** is placed on your desktop. Double-click on the **MINI-ARRAY icon** to launch the program, then follow the configuration and setup procedures described in Section 5 of the primary manual.

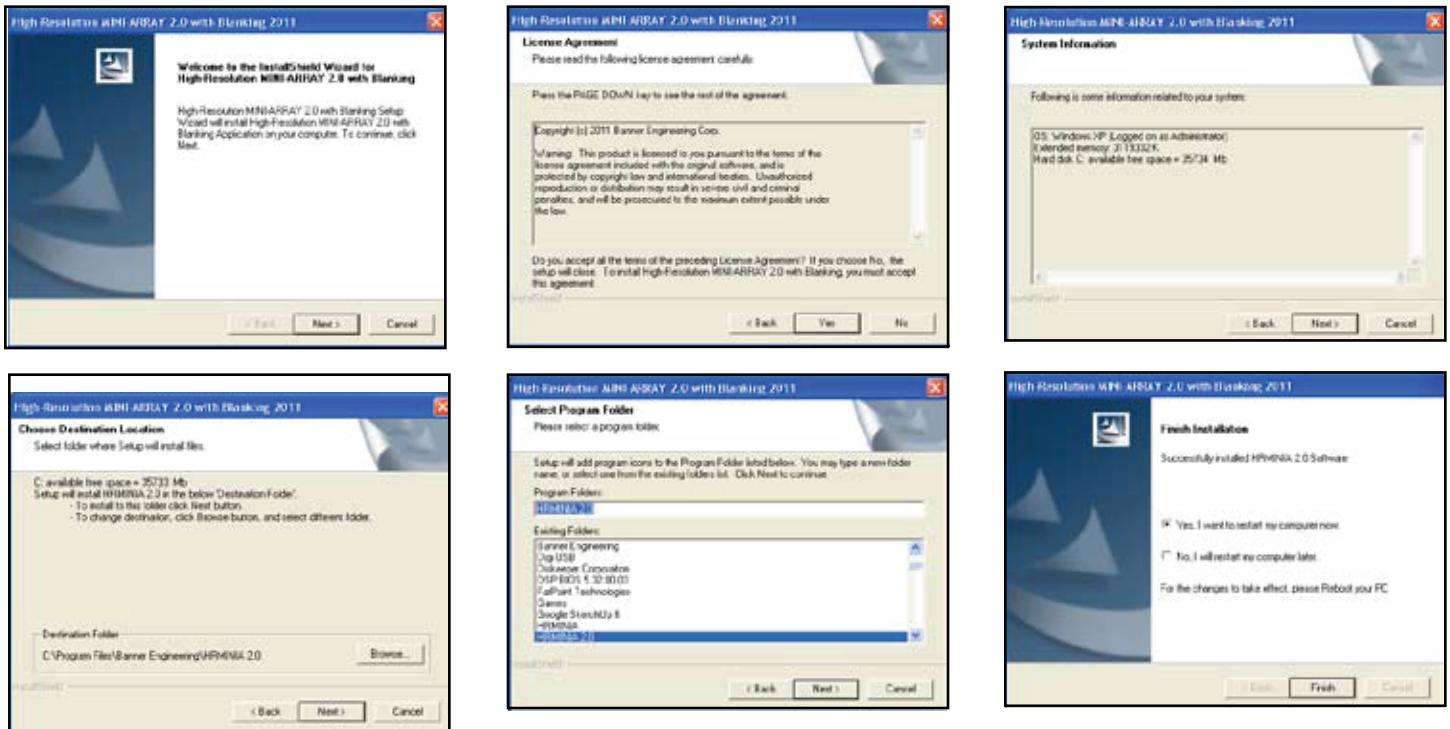

Figure 4-1. MINI-ARRAY software installation: dialog boxes

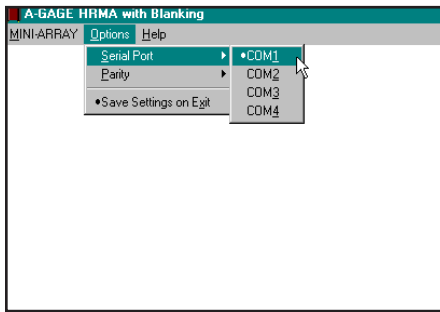

Figure 5-1. Options menu, serial port selection

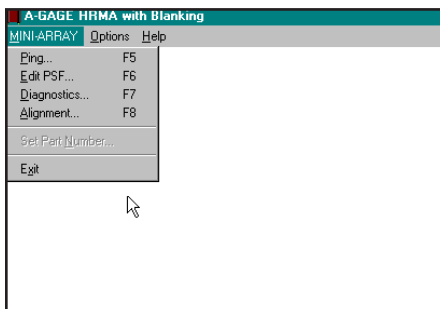

Figure 5-2. MINI-ARRAY menu

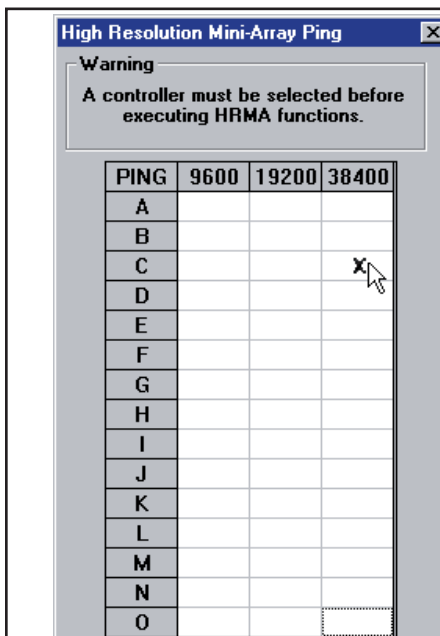

Figure 5-3. Screen showing the result of a completed Ping routine

5. Control Module Configuration

The A-GAGE High-Resolution MINI-ARRAY control module is easily configured using a Windows[®] menu-style routine; the configuration routine requires the Banner-supplied HRMA software and a PC-compatible computer (running Windows[®] XP, Vista, or 7). A serial data connection is made between the computer and the DB9 connector on the control module.

5.1 Communications Setup

After installing the software, attach the serial communication cable between the control module and the PC. (NOTE: If an RS-232 interface is used, only one control module is allowed on the line at any one time.) The minimum connections to the control module's DB-9 connector are shown in Figure 3-8.

Launch the High-Resolution MINI-ARRAY program and configure the serial communications port of the PC. Select the **Options** menu from the High-Resolution MINI-ARRAY main menu (see Figure 5-1). The program supports serial communication via the **COM1-COM20**.port of the computer. Highlight the desired serial port to select it (a "bullet" will appear next to the selected option), then select **Save Settings on Exit** to store the serial port selection, if it is not already ON (a "bullet" will appear next to the option, if it is ON).

Parity is selected here also: Even, Odd or None.

5.1.1 Ping Routine

The Ping routine must be performed during System configuration, and before any Diagnostic, Alignment, or Edit routine. The routine polls all control modules on the communications line (one, in the case of the standard RS-232 line, or up to 15 modules, on an RS-485 circuit). It then is used to select an individual control module for configuration or alignment.

If needed, apply power to the System control module and allow the System to complete its power-up routine. Press **F5** or access the MINI-ARRAY menu and select **Ping** to perform the Ping routine. All connected control modules will then identify themselves with an ID value and baud rate; the routine takes approximately 15 to 20 seconds. After the Ping is performed, all valid control module ID values will appear in a chart on the screen, under their appropriate baud rates (see Figure 5-3). Control modules are identified in the chart as 'X.' Point to a valid ID with the mouse pointer and click to select a control module. System Diagnostics, Alignment, or Edit routines may now be performed for the selected control module.

Control Module Configuration

5.1.2 Factory Settings

Of the 15 available control module ID values ('A' through 'O'), the factory software setting is A. Selectable communication baud rates are 9600, 19200, and 38400; the factory setting is 9600. See section 5.3.1 for information on changing these settings.

5.2 System Alignment

The emitter/receiver pairs have a wide field of view and are easy to align. The recommended distance between the emitter and receiver ranges from 15" to 72". (Shorter sensor separation can be achieved; please consult factory for details.) The Alignment process should be performed at System installation and repeated every time one or both of the sensors is moved. Alignment of the System can be specified automatically using either the Alignment routine of the configuration software or the Alignment switch on the control module's front panel.

The System also may be aligned remotely, using pins 14 and 15 on the terminal block. Apply 10 to 30V dc power to the pins (see page 14) to approximate the push-button procedure. (For example, apply input signal for 3 seconds to access Alignment mode.)

Make sure the sensors have been wired as shown in section 3.3. Apply power to the control module via terminals #1 and #2 (16 to 30V dc). The Diagnostics Indicator will show the sensors going through a power-up test: first the receiver, then the emitter. After the sensors have been tested and the System is ready for service, the Diagnostics Indicator will show '—' or '—.'; see Figure 5-4.

5.2.1 Push-button Alignment Routine

At installation or whenever the emitter and/or receiver is moved, the System should be re-aligned. Press the Alignment switch on the control module front panel for 3 seconds, after which time the letter 'A' will appear on the Diagnostics Indicator; the System is "learning a clear condition." Rotate the sensors as required (but do not change the distance between them). When the green Alignment LED is displayed on the control module and receiver, the sensors are adequately aligned. To leave Alignment mode, again press the Alignment switch for 3 seconds.

During the alignment procedure, the system polls each receiver channel to measure excess gain and performs a coarse gain adjustment. When the system exits the alignment procedure, each channel's signal strength is stored in non-volatile memory. The system is now ready for operation and does not require re-alignment unless the emitter or receiver is moved.

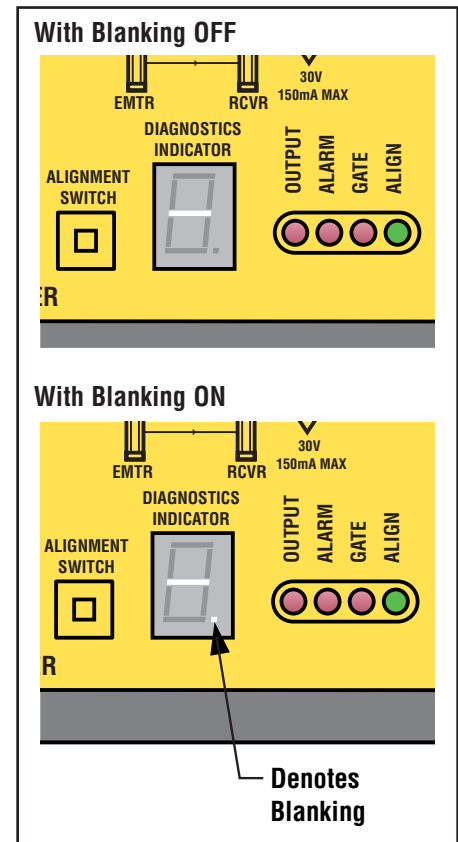

Figure 5-4. Diagnostics Indicator showing a clear condition

5.2.2 Software Alignment Routine

Alignment

Beams

Total: 128

Blocked: 0 Made: 128 Blanked: 0

1 - Made 0 - Blocked B-Blanked

Channels	State
1 - 16	1111 1111 1111 1111
17 - 32	1111 1111 1111 1111
33 - 48	1111 1111 1111 1111
49 - 64	1111 1111 1111 1111
65 - 80	1111 1111 1111 1111
81 - 96	1111 1111 1111 1111
97 - 112	1111 1111 1111 1111
113 - 128	1111 1111 1111 1111

Start
Stop
Step
Clear Blanking
Restore Control
Auto Blank
Abort Auto Blank
Save To File
Read From File
Cancel
Ok

Figure 5-5. Alignment screen

The green LED indicator on the receiver and also on the control module continuously displays Alignment status. When all unblanked beams are clear, the green Alignment indicators will be ON. To better understand blocked, clear and blanked beams, launch the Alignment routine (press **F8** or select **Alignment** under the MINI-ARRAY menu). The screen will show the state of all of the beam channels, grouped into sets of 16.

Key information provided on the Alignment screen is the sensor size, plus the number of beams blocked, made, and blanked. The sensor size is given the title of “total”; this refers to the total number of beam channels in the array. The number of beams blocked is a running total of blocked beams, excluding any blanked beams. The “made” value is a count of unblocked beams. The “blanked value” is a count of the number of beam channels that are blanked (channels that are ignored for measurement mode applications; see section 5.2.3).

The Alignment screen provides the following functions: Start, Stop, Step, Clear Blanking Fields, Restore Control module Settings, Auto Blanking, Abort Auto Blanking, Save to File, Read From File, Cancel, OK, and Edit. To access any of these sub-routines, first press **Stop**, then the selected option.

Start command causes the control module to continuously scan and report “All Channel Data.” This data is used to update the state of each beam channel.

Stop command causes the control module to stop scanning.

Step command produces one scan and then stops until another command is issued.

Clear Blanking Fields command is a quick way to remove blanking specifications.

Restore Control Module Settings will recall the blanking specifications in effect prior to Alignment/Blanking being entered.

Auto Blanking command is used to scan and determine which beams are blocked; blocked beams automatically become blanked beams. The Auto Blanking values can then be **Accepted** or **Aborted**.

Edit is used to control the blanking specifications of any channel manually. This is useful for adding any number of blanked beam channels above and/or below a blanked object to allow for vibration or other movement of the object to be ignored.

Blanking specifications can be saved and read from a computer file using the **Save To File** and **Read From File** commands.

5.2.3 Blanking

If a machine fixture or other equipment will continuously block one or more beams, the affected beam channels may be blanked. The Blanking option causes the control module to ignore the status of blanked beams for measurement mode calculations. For example, if a machine fixture blocks one or more beams during System operation, the output data will be incorrect; if beams blocked by the fixture are blanked, the output data will be correct. Blanking may be configured using the push-button Alignment switch on the control module, or by using the system software and a computer.

Push-Button Blanking Setup Routine

To specify blanking using the control module's Alignment switch, (see Figure 5.4) position the object or part to be ignored in the path of the beams before beginning the Alignment routine. Press the Alignment switch for 3 seconds; the Diagnostics Indicator will show the letter 'A'. Press the Alignment switch again, but this time only momentarily (about 0.5 seconds max.). The Diagnostics Indicator will show the letter 'b' to indicate it is ready to "learn" the blanking pattern. Again, momentarily press the Alignment switch to set the blanking fields. Both the control module and the receiver will indicate a clear condition (green Align indicator ON) and the Diagnostics Indicator will show 'A.' (the period following the 'A' indicates that blanking is in use). The beams blocked during the routine are now blanked. To return to Run mode, again press the Alignment switch for 3 seconds. When the System is ready for operation and configured for beams to be blanked, the period on the Diagnostics Indicator will remain lit, showing '—.' (see Figure 5-4).

System Software Blanking Setup Routine

To specify blanking using the System software, the procedure is similar. Position the object to be blanked in the path of the beams (this can be done at any time before beginning the blanking routine). Perform the Ping routine to select the proper control module, then press **F8** or select the **Alignment** option from the MINI-ARRAY menu. From the screen menu (Figure 5-6), select **Stop**; the Diagnostics Indicator on the control module will show the letter 'A'. Select **Auto Blanking** (Figure 5.7); the Diagnostics Indicator will show the letter 'b'. Select **Accept Auto Blanking**; both the control module and the receiver will indicate a clear condition (green Align indicator ON) and the Diagnostics Indicator will show 'A.' (the period following the 'A' indicates that blanking is in use). The beams blocked during the routine are now blanked and appear as the letter 'B' on the grid instead of '0'; if you wish to blank additional beams, use the 'Edit' key to manually set additional blanking (see next page). To leave Alignment mode, select 'OK'. When the System is ready for operation and configured for beams to be blanked, the period on the Diagnostics Indicator will remain lit, showing '—.' (see Figure 5-4).

Scanning Mode Limitations for Blanking:

All blanking features are available with Continuous Scan mode. For single-and double-edge scan, blanking is limited to four blanking fields. Other blanking features are ignored.

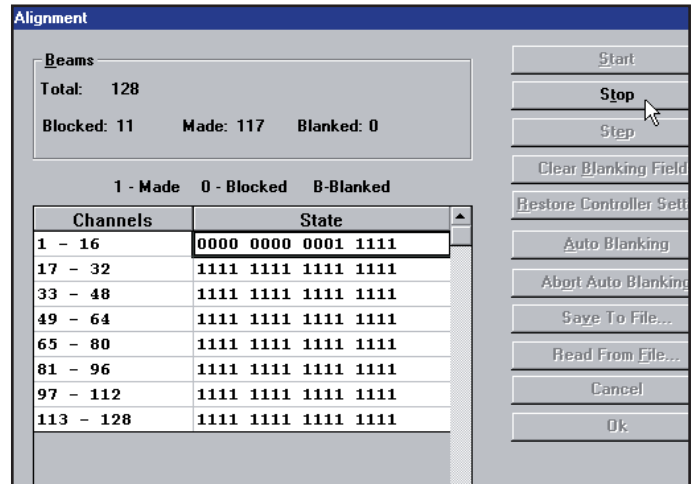

Figure 5-6. Alignment screen, showing beams #1-11 blocked

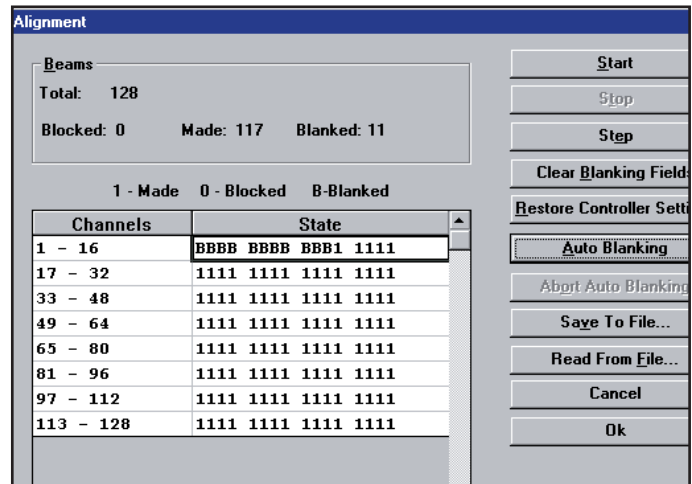

Figure 5-7. Alignment screen, showing beams #1-11 blanked

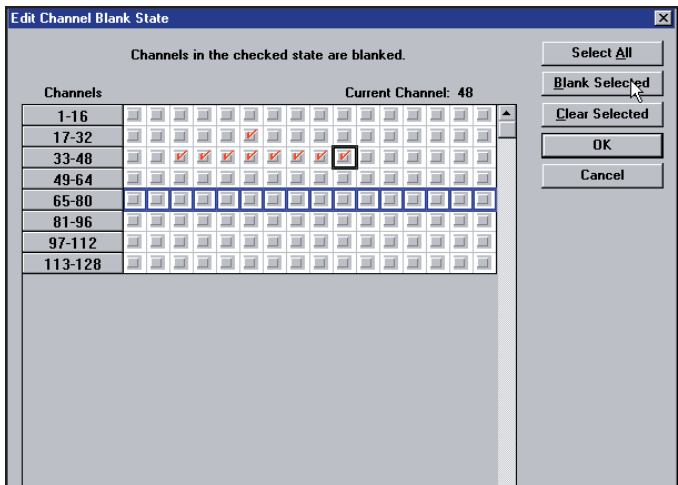

Figure 5-8. Edit channel blank state screen, showing beam #22 and beams #35-42 blanked; beams #65-80 are highlighted, ready to be selected for blanking

To accommodate parts or components that will move through the array, blanking may be manually adjusted for one or more individual beam channels. After using the System software to specify blanking, select **'Edit'** from the Alignment screen; the Diagnostics Indicator will continue to show the letter **'b'** and a grid will appear on the computer screen (Figure 5-8). The beams are numbered from the sensors' cabled ends, with the beam closest to the cable being beam #1. To set the blanking fields, 'click' each grid box representing a beam you wish to blank.

Clicking again on a blanked beam channel will remove the blanking specification. Rows of channels can be selected or cleared of the blanking specification by placing the cursor directly to the left of the row to be selected and clicking the mouse; the row should be highlighted. Select the **Blank Selected** (to accept the blanking status) or **Clear Selected** (to reject the blanking status) option. To leave Alignment mode, select **'OK'**. Both the control module and the receiver will indicate a clear condition (green Align indicator ON) and the Diagnostics Indicator will show **'A.'** When the System is ready for operation and configured for beams to be blanked, the period on the Diagnostics Indicator will remain lit, showing **'—.'** (see Figure 5-4).

5.3 Programming Control Module Response

The Parameter Setup File (PSF) Configuration routine (see Figure 5-9) is used to configure the control module for a specific application. Access the PSF Configuration screen (after performing the Ping routine to select a control module, section 5.1.1) by selecting **Edit PSF (F4)** from the MINI-ARRAY menu. The Edit PSF process may also be performed with no control module selected, to configure and save a PSF for multiple control modules. In such a case, some fields on the PSF Configuration screen will not be accessible.

The process of configuring the control module involves selecting among options for each of the parameters listed in this section, including serial communication, control mode, scanning method, scan analysis mode, serial transmission, and analog/discrete outputs. The resulting combination of options causes the control module to react as required for the application, to changes in the light screen.

The configuration process produces a Parameter Setup File (PSF). PSF files may be saved and retrieved as computer files via the **File Save PSF** and **File Retrieve PSF** commands (see section 5.4.5). Once configured, a PSF may be sent to the control module via the **Send PSF** command. Likewise, the PSF currently loaded into the control module may be displayed by using the **Upload PSF** command.

Control Module Configuration

Selected Controller
Identifies the specific control module being configured.

Control Mode Selection
Continuous Mode: The control module constantly polls the array for status.
Host Mode: The control module polls the array for status when prompted by a host controller.
Gate Mode: The control module polls the array for status when prompted by an input from a Gate sensor.

Scanning Method
Straight scan polls each beam sequentially to determine the target object's overall size. This is the most accurate and precise measurement, but also the most time-consuming.
Single Edge scan requires the target object to block beam 1 (closest to the sensors' cabled ends), then conducts a time-saving binary search to "hunt" for the target's overall height (one variable edge).
Double Edge scan conducts a time-saving search of the entire array to "hunt" for the target's overall width (two variable edges).

Analog and Discrete Output Assignment
Assigns an analysis (measurement) mode to each output.

Analysis (Measurement) Mode Selection
Choose the measurement option that best tells you the size and/or position of objects as they relate to the array.

Serial Communication
Changes the identification and baud rate of the controller being configured.

Serial Transmission
Specifies the type of data transmitted from the control module to its host after each scan.
Measurement Mode Result: Data transmitted will reflect the Analysis Mode selections.
All Mode: Transmits all data.
Max. Meas. Mode: Sends only the largest measurement in each measuring event, to decrease transmission size and speed response. Choose to send when the array is clear or send at the host's request.
Transmission Type: ASCII or Binary, defines the format in which the data will be sent.
Serial Options: Suppress Clear Data or Suppress Header to decrease transmission size and speed response.

Zero Value
Zero Value is used to specify the analog output when the measurement mode value is zero. The user can specify a value of LAST, NULL, or SPAN.

Scan #: (1-9) Analog outputs are updated with an average value of the data received during the selected number of scans; discrete outputs respond only if the received data is identical for all of the selected number of consecutive scans.

Set Point and Hysteresis Selection
Assigns the set point to determine where within the array the output(s) will respond and hysteresis values to smooth output response.

Trigger/Trigger Channel Number
May be used to trigger (or gate) the scan sequence of another A-GAGE High-Resolution MINI-ARRAY controller; in straight scanning mode, it defines when during each scan discrete Output #2 will change state.

Alarm: Causes the control module to turn on discrete Output #2 whenever the System detects a sensing error or if the optical signal becomes marginal.

Figure 5-9. Use the PSF Configuration screen to program each control module individually

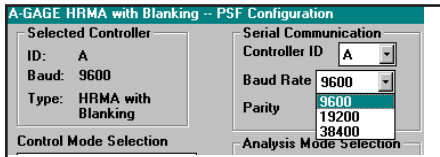

Figure 5-10. Selected Controller and Serial Communication selections (PSF Configuration screen)

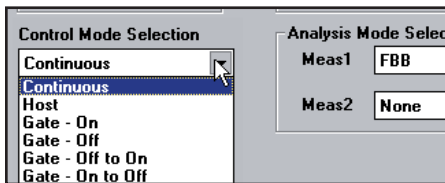

Figure 5-11. Control Mode selections (PSF Configuration screen)

5.3.1 Selected Controller and Serial Communication

The Selected Controller box displays information about the control module being configured. Two of these settings may be changed in the Serial Communication box. The settings selected and displayed in these boxes are those used to identify the control module during the Ping routine (section 5.1.1).

Controller ID (assigned a letter, 'A' through 'O') is used to identify each individual control module when multiple discrete-output control modules (up to 15) are connected on one EIA-485 "party line." NOTE: Analog output control modules do not offer RS-485 communication; choose any ID letter ('A' through 'O') when programming an analog-output control module.

Baud Rate is the data communication rate between the control module and the computer used for configuration and also the process controller. Choose from three values: **9600**, **19200**, and **38400**.

Parity: Select **Odd**, **Even**, or **None**. All controllers on one EIA-485 party line should have the same parity settings.

5.3.2 Control Mode Selection

The control mode determines the method used to control scanning of the light screen array (see Figure 5-11). Choose from three main control modes:

- Continuous Scan mode,
- Serial Host Command mode, and
- Gate mode (which itself has four options)

In Continuous Scan Mode, the control module begins a new scan as soon as it updates the outputs from the previous scan. This is the fastest scan control method; it is used in most analog output applications and whenever continuous updating of the outputs is acceptable.

Host Mode allows the control module to communicate with a host computer or control module via RS-232 (all models) or RS-485 (discrete-output models only) serial protocol. The host directs the control module to scan on demand and receives the output data from the control module in binary or ASCII form. Baud rates of 9600, 19200, and 38400 are selectable in the Serial communications menu (section 5.3.1). (See Appendix A for more information on Host mode data format.)

Gate Mode activates an optically isolated external Gate input between terminals 12 (+) and 13 (-) of the control module. The Gate input has impedance of 7.5 k Ω and accepts a 10 to 30V dc signal. A dc device such as a photoelectric sensor or optical encoder typically supplies the Gate input. Gate input signals must be greater than 150 microseconds in duration; the time between successive Gate inputs must be greater than the minimum scan time for the light screen array (see section 5.3.3 for scan time information).

Gate mode has four options:

- **Gate ON:** the control module will scan as long as the gate is active.
- **Gate OFF:** the control module will scan whenever the gate is not active.
- **Gate ON/OFF:** the control module will scan once for each gate transition from ON to OFF.
- **Gate OFF/ON:** the control module will scan once for each gate transition from OFF to ON.

5.3.3 Scanning Method

The control module may be configured for one of three scanning methods (Figure 5-12):

- Straight scan
- Single-Edge scan
- Double-Edge scan

Straight Scan is the default mode in which all beams are scanned in sequence from the bottom end (cable end) to the top end of the array. This scanning method requires the longest scan times and provides the smallest object detection size (2.5 mm, 0.1" diameter).

Single-Edge Scan is used to measure the height of a single object. A good application for this scanning method is box height measurement. For Single-Edge Scan, the System always activates the first beam channel (nearest the cable end, or "bottom"). If the first beam is blocked, the sensor will perform a binary search to hunt for the last beam blocked. Single-Edge Scan works as follows:

1. The receiver scans only the bottom beam until that beam is blocked.
2. When the bottom beam is blocked, the sensor looks to see whether the middle beam is blocked or made (unblocked).
3. If the middle beam is made (unblocked), the sensor checks the bottom quarter beam; if the middle beam is blocked, the sensor checks the top quarter beam. (This is called a binary search; see Figure 5-13.)
4. This routine continues to "narrow the field" until the edge is found.

Note that the receiver always checks the bottom beam first, and only if that beam is blocked does the binary search continue. Therefore, Single-Edge Scan will not work in instances where an item that does not block the first beam is to be measured. Single-Edge Scan is also ineffective if the object does not present a continuous blocked pattern. In other words, Single-Edge Scan is used for single, solid objects that block the first beam.

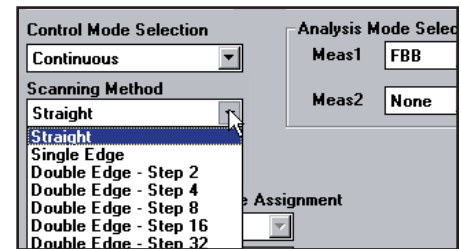

Figure 5-12. Scanning Method selections (PSF Configuration screen)

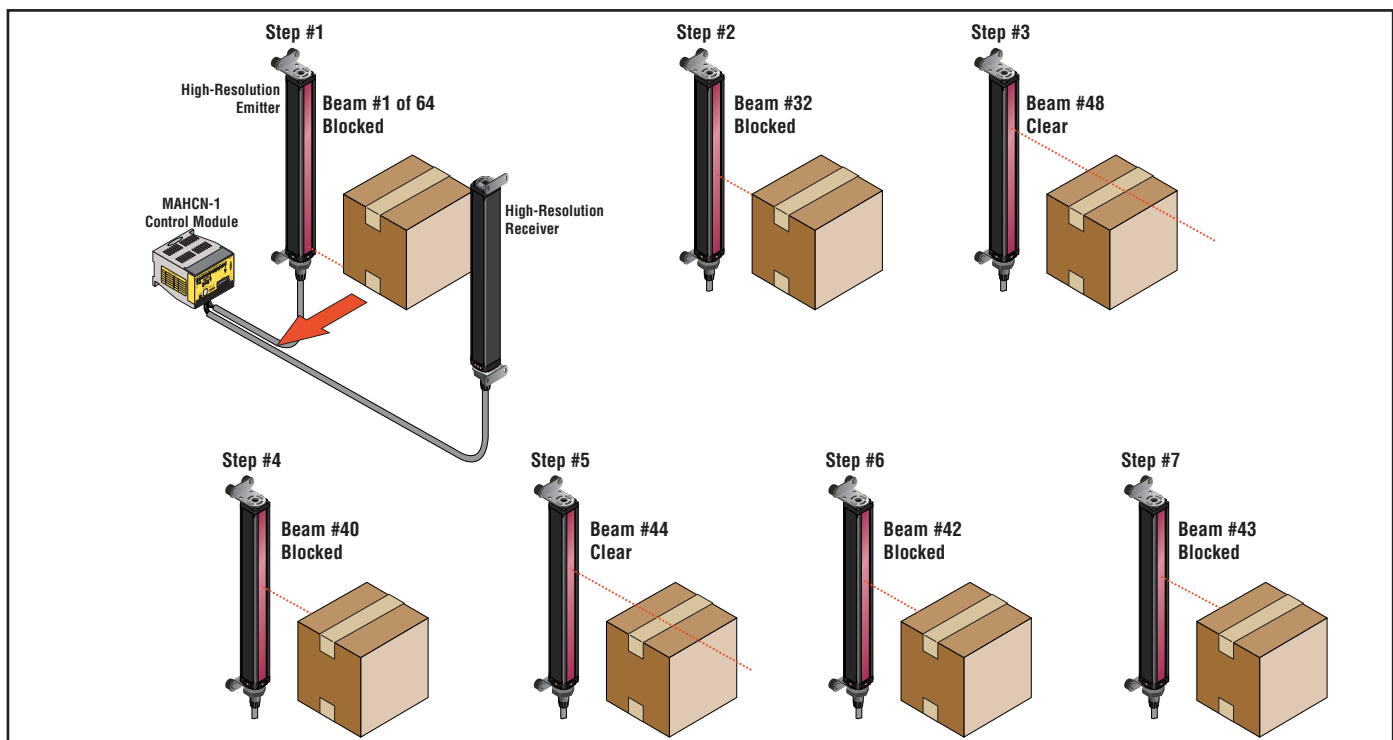

Figure 5-13. Finding an edge using a binary search

Double-Edge Scan is used to detect two edges of a single object, for example, box width measurements. Double-Edge Scan requires the selection of a step size: 2, 4, 8, 16 or 32 beams. The sensor uses the steps to “skip” over beams. Double-Edge Scan works as follows:

1. The sensor activates beam #1 (the beam closest to the sensor cable end).
2. The sensor activates the next beam, determined by the step size. (For example, if the step size is 2, beam #3 is next; if the step size is 8, beam #9 is next.)
3. As long as the activated beam is unblocked (or “made”), the sensor will continue the stepping routine until a blocked beam is found.
4. When a blocked beam is found, a binary search is conducted to find the object’s “bottom edge.”
5. When the bottom edge is found, the sensor begins “stepping” again through the array until the sensor finds the next unblocked beam.
6. A binary search is again performed to find the second edge.

Note that this scanning method sacrifices object detection size for speed. Similar to Single-Edge Scan, Double-Edge Scan has some restrictions: the object should provide a solid obstruction; the size of the object will determine the maximum step size (Figure 5-14).

Step Size	Number of Beams				
	2	4	8	16	32
Minimum Object Detection Size	5 mm (0.2")	10 mm (0.4")	20 mm (0.8")	40 mm (1.6")	80 mm (3.2")

Figure 5-14. The effect of step size on minimum object detection size

Sensor response time is a function of sensor length and scanning method. Typical scan times are shown in Figure 5-15.

Maximum Scan Times (in milliseconds)							
Array Length	Straight Scan	Single-Edge Scan	Double-Edge Scan				
			Step 2 Beams	Step 4 Beams	Step 8 Beams	Step 16 Beams	Step 32 Beams
163 mm (6.4")	5.8	1.8	4.8	3.4	2.7	2.5	2.6
325 mm (12.8")	10.6	1.9	8.1	5.1	3.6	3.0	2.7
488 mm (19.2")	15.0	2.1	11.5	6.8	4.5	3.4	3.0
650 mm (25.6")	20.1	2.1	14.9	8.5	5.3	3.9	3.2
812 mm (32.0")	24.9	2.1	18.3	10.1	6.1	4.2	3.5
975 mm (38.4")	30.0	2.1	21.7	11.8	7.0	4.7	3.6
1138 mm (44.8")	34.5	2.1	25.0	13.5	7.9	5.1	3.8
1300 mm (51.2")	39.3	2.1	28.4	15.2	8.7	5.5	4.1
1463 mm (57.6")	44.0	2.2	31.8	16.9	9.5	5.9	4.3
1626 mm (64.0")	48.0	2.3	35.1	18.6	10.4	6.4	4.5
1788 mm (70.4")	53.6	2.3	38.5	20.3	11.2	6.8	4.7
1951 mm (76.8")	58.4	2.3	41.9	21.9	12.1	7.2	4.9

Figure 5-15. The effect of sensor length and scanning method on scan time (typical)

NOTE: Scan times are exclusive of serial communication transmission times.

Control Module Configuration

5.3.4 Scan Analysis Mode Selection

The control module may be programmed, if desired, for any one or two of seven Scan Analysis (measurement) Modes. Each selected mode may be assigned individually to an output (see section 5.3.5 or 5.3.6). The beams in the array are numbered in sequence, with beam #1 located at the cabled end of the emitter and the receiver.

“Beam Location” Modes

- **First Beam Blocked (FBB):** The control module identifies the location of the First Beam Blocked.
- **First Beam Made (FBM):** The control module identifies the location of the First Beam Made (unblocked).
- **Last Beam Blocked (LBB):** The control module identifies the location of the Last Beam Blocked.
- **Last Beam Made (LBM):** The control module identifies the location of the Last Beam Made (unblocked).
- **Middle Beam Blocked (MBB):** The control module identifies the location of the Middle Beam Blocked, midway between the first and last beams blocked.

“Beam Total” Modes

- **Total Beams Blocked (TBB):** The control module totals the number of blocked beams.
- **Total Beams Made (TBM):** The control module totals the number of made (unblocked) beams.
- **Contiguous Beams Blocked (CBB):** The control module identifies the largest number of consecutively blocked beams.
- **Contiguous Beams Made (CBM):** The control module identifies the largest number of consecutively made beams.
- **Transitions (TRN):** The control module counts changes from blocked to clear and clear to blocked. For instance, if beams 6-34 are blocked, then there is a clear-to-blocked transition from beam 5 to beam 6, and a blocked-to-clear transition from beam 34 to beam 35. Transition mode can be used to count objects within the array.

The Analysis Mode(s) programmed may be assigned to any one of the available outputs (see Figure 5-18). Each output can be set for **MEAS1**, **MEAS2**, **MEAS1 Inverted** or **MEAS2 Inverted**.

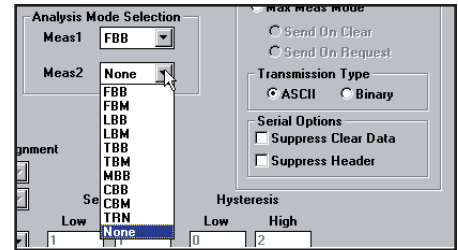

Figure 5-16. Scan Analysis Mode Selection (PSF Configuration screen)

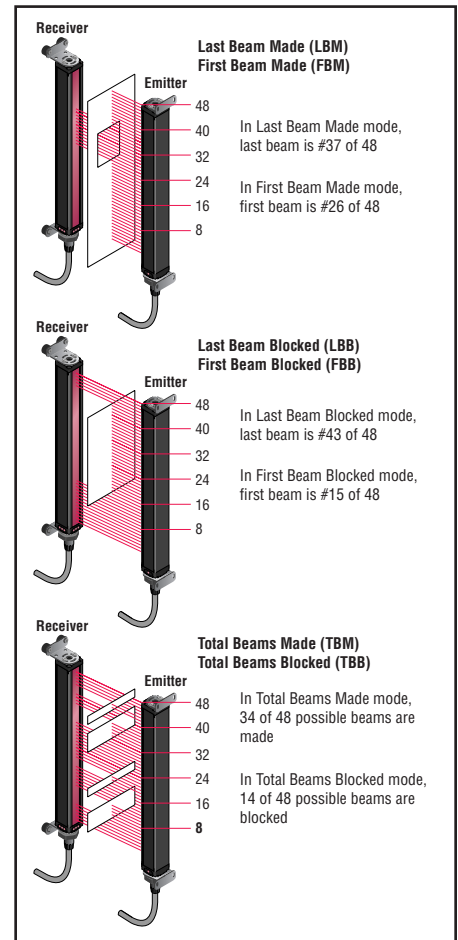

Figure 5-17. Examples of MINI-ARRAY scan analysis modes

5.3.5 Analog Output Configuration (Analysis Mode Assignment)

Analog outputs #1 and #2 may each be assigned to one of the analysis modes described in section 5.3.4. When the selected Scan Analysis Mode involves first or last beam blocked or made (unblocked), the assigned output will vary in proportion to the beam number identified during a scan. When the Scan Analysis Mode involves total beams blocked or made, that assigned output will vary in proportion to the total beams counted during a scan.

Note that the pull-down menus used for assignment of the Scan Analysis Modes to the analog outputs include two “Inverted” selections. When either **MEAS1 Inverted** or **MEAS2 Inverted** is selected, that analog output will decrease as the measurement mode value increases. An inverted output will be at full scale (**Span** value) when the scan analysis value is zero; and at maximum scan analysis value, the output will be at the **Null** value.

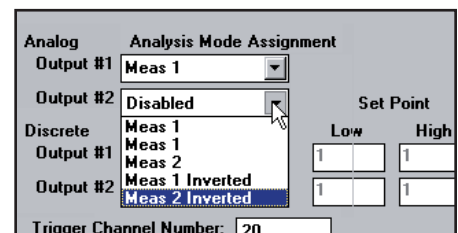

Figure 5-18. Assigning an Analysis Mode to each Analog Output (PSF Configuration screen)

NOTE: When in the Null/Span screen, the controller will have a diagnostic code of 8.

The **Null/Span** Configuration screen (Figure 5-19), may be used to adjust the zero and full scale reading for either analog output. To display the Null/Span Configuration screen, click on the Null/Span button at the bottom of the PSF Configuration screen (Figure 5-9). Each output is independent and must be adjusted separately. Adjust the **Null** and **Span** values either by moving the slide bars, or by entering a new value on the keyboard.

To Measure:

Analog Voltage Output: Connect the voltmeter between terminals 10 or 16 (+) and 17 (-).

Analog Current Output: Connect the ammeter between terminals 10 or 16 (-) and 1 (+).

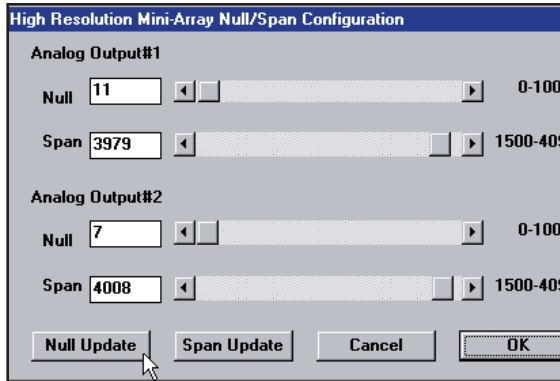

Figure 5-19. Null/Span Configuration screen

Analog Output Type	Null		Span	
	Minimum	Maximum	Minimum	Maximum
Voltage	10 mV	2.3 V	4.8 V	10.1 V
Current	3.9 mA	7.8 mA	11.9 mA	20.2 mA

The Null and Span ranges may be adjusted as follows:

To read the new values on the meter, click on **Null** or **Span Update**. Click on the **OK** button to save the new settings and return the program to the PSF Configuration screen. Clicking on the **Cancel** button returns the program to the previously saved null and span settings.

NOTE: Null and Span are factory set to specified values and usually require no changes.

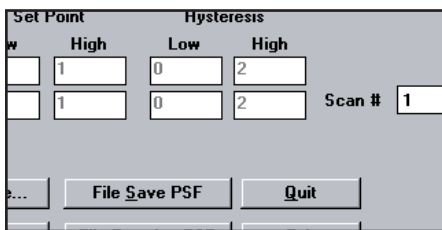

Figure 5-20. Scan # (PSF Configuration screen)

Scan # Provides a way to smooth output response and avoid unstable analog output conditions. The menu allows selection of from 1 to 9 scans (see Figure 5-20). For analog outputs, if scan # is set at more than 1, the scan analysis value is averaged for all of the selected number of consecutive scans, preventing dips and spikes in the outputs.

For total beam values (TBB and TBM analysis modes), programming of blanked beams (section 5.2.3) will affect the proportional analog outputs. Blanked beams are ignored both in the number of blocked or made beams and the total number of beams. For example, if a 64-beam array has 20 blanked beams and 22 of the remaining 44 beams are blocked, the output values will be at mid-range.

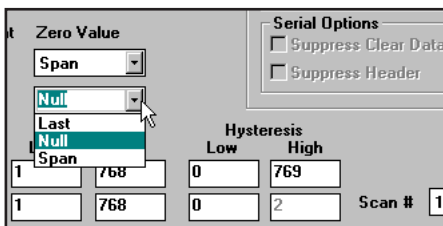

Figure 5-21. Zero Value (PSF Configuration screen)

5.3.6 Zero Value

Zero value is used to specify the analog output when the measurement mode value is zero. The user can select an analog output of LAST, NULL, or SPAN.

- LAST:** Output holds the last non-zero value before the light screen became clear.
- NULL:** Provides the minimum value
- SPAN:** Provides the maximum value.

5.3.7 Discrete Output Configuration (Analysis Mode Assignment)

Discrete outputs #1 and #2 (“Alarm”) may each be individually assigned to one of the Scan Analysis Modes programmed in section 5.3.4 (see Figures 5-16 and 5-22).

Next to each discrete output assignment menu are **Low** and **High Set Point** boxes. The number in each box identifies a beam in the array (beam #1 being closest to the cabled end of the emitter and the receiver). The Low and High Set Points may be changed by clicking on a box and entering a new number.

When the selected Scan Analysis Mode involves first or last beam blocked or made (unblocked), the assigned output will energize when the beam identified during a scan falls within the range of the set points. When the Scan Analysis Mode involves total beams blocked or made, that assigned output will energize when the value of total beams counted during a scan falls within the range of the set points.

Note that the pull-down menus used for assignment of the Scan Analysis Modes to the discrete outputs include two “Inverted” selections. When either **MEAS1 Inverted** or **MEAS2 Inverted** is selected, that discrete output will de-energize (turn OFF) whenever a scan analysis value falls within the range of the set points.

Hysteresis values for each end of the set point range may also be set (Figure 5-22). Hysteresis determines the amount of change that must occur at each set point (**High** and **Low**) to cause the associated output to change state. Hysteresis prevents unstable output conditions when the scan analysis value exactly matches one of the set points. The default hysteresis setting is one beam less than the Low Set Point and one beam more than the High Set Point.

Scan # Provides another way, in addition to hysteresis settings, to smooth output response. Outputs are updated only after the selected number of identical (within the hysteresis limits) scans. The menu allows selection of from 1 to 9 scans. For discrete outputs, the scan analysis value must stay either inside or outside the hysteresis limits for all of the selected number of consecutive scans, in order for the output to respond. See Figure 5-23.

Alarm and Trigger

Discrete output #2 (only) has two additional options: Alarm and Trigger.

Alarm: Output #2 energizes whenever the System detects a sensor error (such as a disconnected cable) or whenever the excess gain of one or more beams becomes marginal.

Trigger: can be used to gate a second control module when Continuous Scan Method is also used. When the control module is in straight scanning mode, **Trigger Channel Number** defines the beam number during a scan at which the trigger output will occur (Figure 5-23). The Trigger output is a 100 microsecond (0.0001 sec.) pulse. If the control module is set for single or double edge scan, the **Trigger** pulse will come at the end of the scan (**Trigger Channel Number** will be ignored).

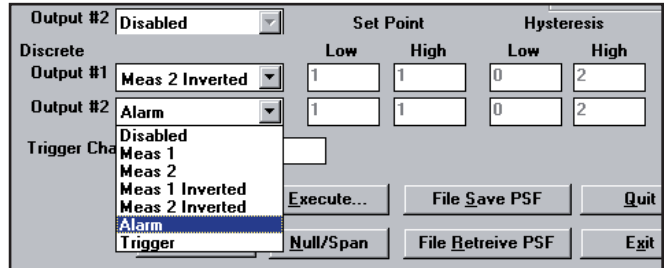

Figure 5-22. Assigning an Analysis Mode to each Discrete output (PSF Configuration screen). Alarm and Trigger output options are available only for Discrete Output #2.

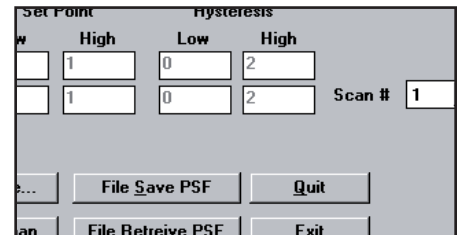

Figure 5-23. Scan # (PSF Configuration Screen)

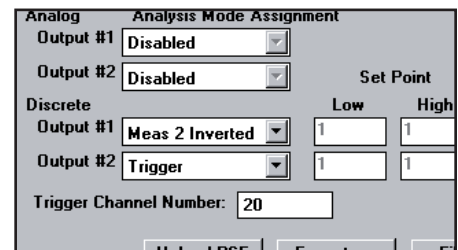

Figure 5-24. Trigger Channel

5.4 Serial Communication with a Host Controller

The control module communicates with a host process controller via RS-232 or RS-485 protocol and at the baud rate specified in the Serial Communications box (section 5.3.1). The System provides a number of data transmission options.

5.4.1 Serial Data Transmission

The serial transmission portion of the PSF Configuration screen activates the serial port(s), specifies the data format, and provides data suppression options. These settings are required to allow a control module to communicate with a host computer or process controller. If **No Serial Communication** is selected (the default setting), the serial port(s) will not transmit sensing data.

Measurement Mode Result: data transmitted will be the values output for the Scan Analysis Mode selections. Up to two Scan Analysis Mode selections can be active.

ALL Mode: the status of each beam in the light screen array will be transmitted for **each scan**. In ALL mode, blanked channels are transmitted as unblocked (or clear) beams.

Max Meas Mode: the control module records the maximum measurement value registered while the light screen is blocked. That data may be transmitted to the host either when the array is clear at the end of the sensing event (select **Send On Clear**), or when prompted by the host (select **Send On Request**). This mode reduces the amount of serial data sent.

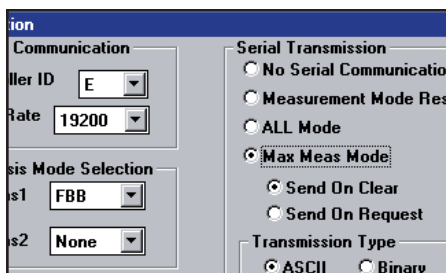

Figure 5-25. Serial Data Transmission options (PSF Configuration screen)

5.4.2 Transmission Type

Transmission type defines the format in which data is sent. The **ASCII** option causes the control module to send data in three ASCII-coded bytes. The **Binary** option causes data to be sent in binary format, reducing the amount of data per measurement mode from three bytes to two. For more information on the data formats, refer to Appendix A.

Control Module Configuration

5.4.3 Serial Options

The Serial Options box provides two options: **Suppress Clear Data** and **Suppress Header**.

Suppress Clear Data provides one method to reduce the amount of data being transmitted by the control module, accomplished by not sending data when no object is detected. The control module transmits serial data only when one or more unblanked beams of the light screen array are blocked. When the array goes from blocked to clear, data is sent one additional time, indicating the clear condition.

Suppress Header is used to prevent transmission of the three-byte identification string (“header string”) associated with either ASCII or Binary data formats. The header string consists of two bytes at the start of the data, and a termination byte to mark the end of the serial transmission. See Appendix A for more information on serial data formats.

5.5 Transfer of PSF to the Control Module

After making all of the selections in the PSF Configuration screen, the PSF may be sent to the control module by clicking the **Send PSF** button (see Figure 5-26). This command loads the PSF into the non-volatile memory of the control module, and automatically overwrites the current PSF. The program will confirm that the PSF was accepted, or will notify the user of changes required to the PSF.

To check the values of the PSF currently loaded into the control module, select **Upload PSF**. The current PSF will be displayed on the PSF Configuration screen.

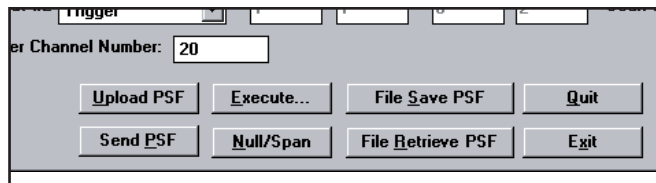

Figure 5-26. PSF Output options (PSF Configuration screen)

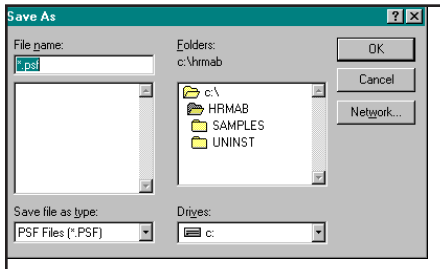

Figure 5-27. FileSave subsection of the PSF Configuration screen, accessed with the File Save PSF command

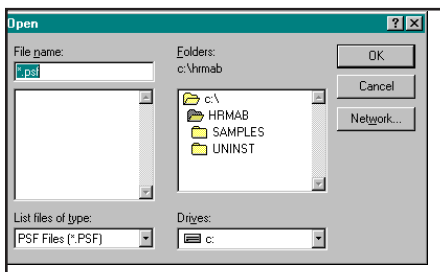

Figure 5-28. FileBox subsection of the PSF Configuration screen, accessed with the File Retrieve PSF command

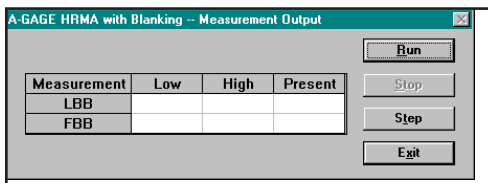

Figure 5-29. Measurement Output subsection of the PSF Configuration screen, accessed with the Execute command

5.5.1 Saving and Recalling PSF Files

To place the displayed PSF into a file that can be retrieved at any time, select **File Save PSF** (Figure 5-26). When asked if you want to save the PSF to a file, select **Yes**. A subsection titled FileSave will appear (Figure 5-27). Overtyping '* .psf' in the File Name entry box with the name of the file to be stored (up to 8 characters), plus the .psf extension; then select **OK** (or press **Enter**). The PSF will be stored on the selected drive (default is 'c:') and the program will automatically return to the PSF Configuration screen.

To retrieve a filed PSF, select **File Retrieve PSF**. The FileBox subsection will appear (Figure 5-28). Select the desired PSF from the File Name list and select **OK** (or press **Enter**). The selected PSF will load to the PSF Configuration screen, and it can then be loaded into the controller using the **Send PSF** command.

5.5.2 PSF Output Analysis

To view activity in the array in response to the currently loaded PSF, select **Execute** (Figure 5-26). The Measurement Output screen will appear (Figure 5-29); select **Run**. The table will display the status for the selected measurement mode(s), including the **Present** value and the **High** and **Low** values for the **Run** period.

Select **Stop** to “freeze” the data. Select **Step** to initiate a single scan of the array to simulate a “snapshot” of what is viewed by the array at the instant that **Step** is selected.

Use of the **Execute** command is especially beneficial for testing the response of a gated system. **Run** simulates the Continuous Scanning mode, and **Step** simulates a gate input command.

5.5.3 Quit and Exit

To close the PSF Configuration screen, select either **Quit** or **Exit** (Figure 5-26). Selecting **Quit** erases the Edit PSF Screen and sends the user back to the Main Window; the present PSF Screen values are not retained. The **Exit** command is similar to the **Quit** command, except the user will be prompted to save the configuration values to a parameter setup file (PSF).

6. System Diagnostics

System diagnostics may be performed using the status and diagnostics indicators on the control module and sensors, or by using the Diagnostics software routine, or a combination of the two.

6.1 Diagnostics Indicators

NOTE: Status indicators appear to “freeze” if the controller has been configured for Gate or Host mode (Section 5.3.2), and no signal is present to cause a scan update.

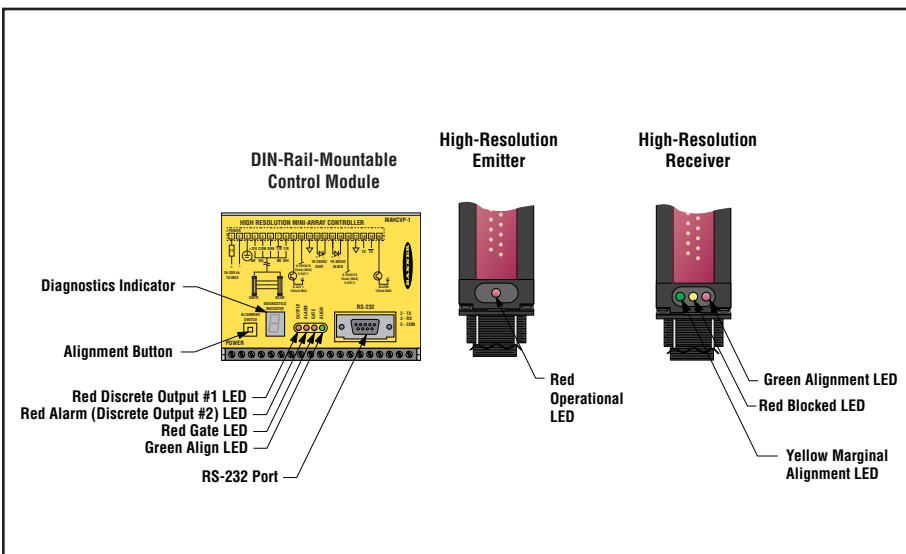

Figure 6-1. A-GAGE High-Resolution MINI-ARRAY System diagnostics and status indicators

Bright, easy-to-see LED indicators on both sensors and on the front panel of the control module provide an ongoing display of the system’s operating status.

Control Module:

OUTPUT: (red) displays the status of Discrete Output #1.

ALARM: (red) displays the status of Discrete Output #2. This output may be assigned to an analysis mode, or it may be used as a System Diagnostics alarm or as a Trigger alarm to gate another A-GAGE High-Resolution MINI-ARRAY System.

GATE: (red) displays the status of the Gate input.

ALIGN: (green) indicates proper emitter/receiver alignment and a clear, unblocked light screen. This indicator is ON when either the green or both the green and yellow LEDs of the receiver are ON.

DIAGNOSTICS	
Error No.	Error Type/Action
-	System is OK
A / b	Align / blank • Status
1	Output Short • Check output load & wiring
2	E / R Mismatch • System must use same length emitter and receiver
3	Receiver Error • Check receiver cable • Replace receiver
4	Emitter Error • Check emitter cable • Replace emitter
5	Serial Comm • Check serial cable
6	EEPROM • Reconfigure PSF • Replace control module • Reconfigure blanking
7	CPU Error • Replace control module
8	Null / Span • Status

Figure 6-2. Key to System Diagnostics Indicator codes

Diagnostics Indicator: This bright, segmented LED display on the control module front panel indicates one of 10 System status conditions, plus the presence or absence of blanking. (Blanking ON causes a period to appear in the Diagnostics Indicator window, in addition to the System's other status condition.) See Figure 6-2 for the key to these error types and status conditions; this chart is also located on the side of the control module.

Emitter:

OPERATIONAL: (red) LED indicates power to the emitter is ON, and unit is operational.

Receiver:

BLOCKED: (red) LED indicates some of the array beams are blocked.

MARGINAL: (yellow) LED indicates that array alignment is marginal.

ALIGNMENT: (green) LED indicates that array alignment is satisfactory.

To improve alignment, adjust the position of the emitter and receiver until the green LED lights, making sure that no unblanked beams are interrupted. Then use one of the methods in Section 5.2 to realign the system.

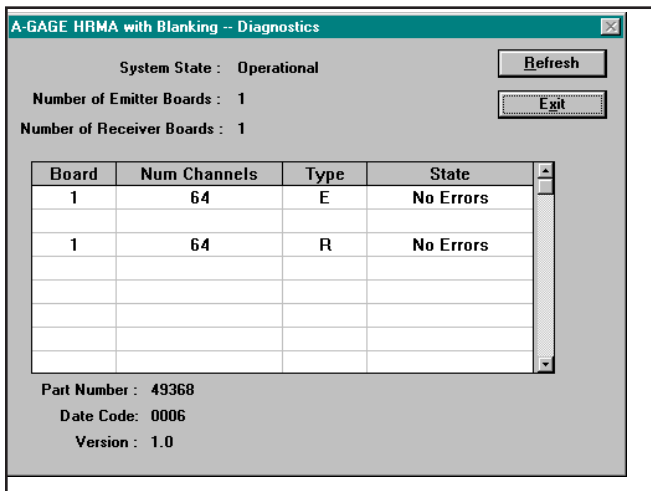

Figure 6-3. Diagnostics screen, accessible from the MINI-ARRAY menu

6.2 Diagnostics Routine

Emitter or receiver problems may be further diagnosed using the Diagnostics routine included with the MINI-ARRAY software. Launch the program by selecting **Diagnostics** under the MINI-ARRAY menu (Figure 5-2) or by pressing **F2**.

The Diagnostics screen (Figure 6-3) displays the size of each emitter and receiver (expressed in the number of 64-element “boards” it contains) and its functional status (or state). If an error has occurred, the specific problem beam channel is identified. Additionally, if there is a problem with an emitter or receiver cable connection, a “**No Response**” message is displayed.

The Diagnostics routine also displays the part number and date code of the controller, information that may be useful if factory-assisted troubleshooting by telephone is required.

Appendix A: Data Transmission

A.1 Host Mode Command String

As discussed in section 5.3.2 of this manual, the control module has three control mode options: continuous, gate, and host. Host mode requires a serial transmission string from a separate device, typically a PC or process controller. The serial transmission medium can be either RS-485 or RS-232.

When Host control mode is selected, the host process controller initiates scans using a command string. The command string is a three-byte message, consisting of:

- Control byte with decimal value 248,
- Controller ID (the identification of a specific control module on the string, indicated by one of 15 ASCII letters A through O, and specified in the PSF), and
- Scan initiation byte (ASCII letter S).

The command string is further defined as follows:

```
/*the below C code will define an array called msg that will contain the Host Scan Command */  
unsigned char msg[3]; /*declare three byte unsigned character array using C language */  
msg[0]=248; /*control byte */  
msg[1]=65; /*assume the controller ID is the letter A */  
msg[2]=83; /*assume initiation byte which is the ASCII letter S */
```

The host transmits this three-byte message at the defined baud rate. The format is one start bit, one stop bit, even parity, and eight data bits. When the control module receives this message, it initiates a scan (assuming Host mode is selected) and then updates its outputs as required. The control module then waits for the next Host Command message before initiating another scan.

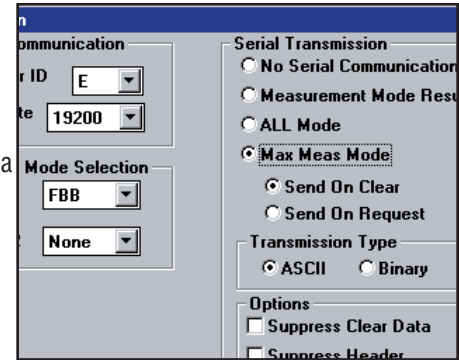

Figure A-1. Serial Transmission options (PSF Configuration screen)

A.2 Serial Data Format and Header String

The programmed measurement mode or modes determine the type of information that is serially transmitted. For example if Meas1 is set for FBB and Meas2 is set for LBB, then the data transmitted to the host contains the values of the first and last beam blocked. The All measurement mode provides the status of all beams to the host.

In addition to measurement mode information, the data transmission also contains a two-byte start string and a termination byte. The start string consists of a first byte that does not change, followed by the controller ID. The first byte value is a hex 1C or 28 decimal. At the end of the string, the control module will place a termination byte. The termination byte is the ASCII character for a linefeed (hex value 0A). These three bytes collectively are called the Serial Header string.

Definitions for ASCII Data Values				
For the ALL measurement mode				
Character	Ch 4	Ch3	Ch2	Ch1
F	1	1	1	1
E	1	1	1	0
D	1	1	0	1
C	1	1	0	0
B	1	0	1	1
A	1	0	1	0
9	1	0	0	1
8	1	0	0	0
7	0	1	1	1
6	0	1	1	0
5	0	1	0	1
4	0	1	0	0
3	0	0	1	1
2	0	0	1	0
1	0	0	0	1
0	0	0	0	0

Figure A-2. ASCII data values

A.2.1 ASCII Format Data Transmission

There are two ways to use ASCII format to represent data. The one used depends upon which measurement modes are selected.

For ALL measurement mode, each data byte is presented in an eight-bit ASCII format that conveys the status of four consecutive channels (four consecutive beams). Each subsequent byte conveys the status of the next four channels, until the status of every channel is reported. The allowable data values for All measurement mode are ASCII numbers 0 to 9 and ASCII letters A to F. In the table, a '0' represents an unblocked beam channel, and '1' represents a blocked channel.

For example, assume that a 64-channel system has been configured for the All measurement Serial transmission option. Channels 1 through 4 are blocked, as is channel 63. The serial string starts with 0x1c, and the ID (assume an 'A') followed by 16 ASCII values and terminated with 0x0A. The string would appear:

0x1c, 'A', 'F', '0','0', '0','0', '0','0', '0','0', '0','0', '0','0', '0','4', 0x0a

The string shows that beams 1 through 4 are blocked, as is beam 63. All other beams are unblocked. If the user had requested suppression of the header, then 0x1c, 'A', and the 0x0a would have been deleted.

For transmitting Measurement mode data, use three ASCII bytes to represent each measurement mode. For example, if Meas1 is FBB, Meas2 is LBB, the measured values are 6 and 120, and the controller ID is B, the data string is as follows:

0x1c 'B', '0', '0', '6', '1', '2', '0', 0x0a

As with ALL mode, the header and clear data could be suppressed. For clear data suppression, the control module sends the status of a clear condition only on the first "clear" scan. After that, the control module will continue to scan but will not transmit data until the sensor is again blocked.

A.2.2 Binary Format Data Transmission

First Data Byte		Second Data Byte	
Channel	Bit Position	Channel	Bit Position
1	7	9	7
2	6	10	6
3	5	11	5
4	4	12	4
5	3	13	3
6	2	14	2
7	1	15	1
8	0	16	0

Figure A-3. Binary data values

Similar to ASCII format, binary format may be used to represent data in two ways. One method involves the All Data transmission mode; the other, Measurement mode.

For All Data transmission mode, the control module represents the status of eight consecutive data channels for each byte. Each bit of each byte is directly related to the status of an individual channel. The first data byte represents channels 1 through 8; the second data byte represents channels 9 through 16. The bit pattern for the first and second data bytes is as shown in Figure A-3.

For each bit position, 1 represents a blocked beam and 0 represents an unblocked beam.

For example, for a 64-channel system with beams 1-6 blocked, beam 43 blocked and beams 62-64 blocked, the data transmitted from control module 'A' is as follows:

0x1c, 'A', 0xFC, 0x00, 0x00, 0x00, 0x00, 0x20, 0x00, 0x07, 0x0A

This string would have the start byte, controller ID, followed by the eight data bytes and terminated with the 0x0A. The header bytes may be suppressed if necessary.

Appendix A: Data Transmission

For **Measurement mode analysis**, the binary format uses two data bytes for each measurement mode. (If we have one measurement mode, then there are two data bytes. For two measurement modes, there are four data bytes.)

For example, assume that control module 'B' is configured for one measurement mode (FBB), and the value is 78. The string from the control module is as follows:

0x1c, 'B', 0x00, 0x4E, 0x0A. (a total of five bytes)

or

0x00, 0x4E (a total of two bytes with Suppress Header option)

Now assume that control module 'B' is configured for FBB and LBB with values of 74 and 303, respectively. The string from the control module is as follows:

0x1c, 'B', 0x00, 0x4A, 0x01, 0x2F, 0x0A (a total of seven bytes)

or

0x00, 0x4A, 0x01, 0x2F (a total of four bytes with Suppress Header option)

A.3 Max Meas Mode Command String

Max Meas Mode causes the control module to retain the maximum measurement values for a given object. These values are transmitted either immediately after the control module is cleared or when prompted by the Host. The Max Meas Mode Command String is a four-byte string that appears as follows:

- Control byte with decimal value 248
- Controller ID (one of 15 ASCII letters A through O, as specified in the PSF)
- Max Meas Command Transmit (ASCII letter T).
- Termination byte with decimal value 13

The command string is further defined:

```
/*the below C code will define an array called msg which will contain the Max Meas Mode Command String*/
```

```
unsigned char msg[4]; /*declare four byte unsigned character array using C language */  
msg[0]=248; /*control byte */  
msg[1]=65; /*assume the controller ID is the letter A */  
msg[2]=84; /*assume initiation byte which is the ASCII letter T */  
msg[3]=13; /*termination byte */
```

When the host sends this string, the control module sends the maximum values stored from the previous scanned object. If the sensor is presently scanning an object when the message is sent, the control module will give the maximum values for the present object.



Appendix B: Glossary

Appendix B: Glossary

Blanked Beam: A beam that is “ignored” by the receiver, as a result of a blanking program being applied to it. Beams (or groups of beams) are blanked when a component or fixture will remain in or move through the light screen array; blanking the affected beams prevents the component or fixture from causing false outputs.

Blocked Beam: A beam that is obstructed between the emitter and the receiver, and is not blanked.

Clear Beam: A beam that runs unobstructed from the emitter to the receiver (same as a made or unblocked beam).

Excess Gain: A measurement of the amount of light falling on the receiver from the emitter over and above the minimum amount required for operation. A-GAGE High-Resolution MINI-ARRAY emitters and receivers automatically perform an Alignment procedure to equalize the amount of excess gain at each element along the array.

Host: A computer or process controller that controls and receives input from the High-Resolution MINI-ARRAY System, and/or other equipment and systems within a factory.

Made Beam: A beam that runs unobstructed from the emitter to the receiver (same as an unblocked or clear beam).

Unblocked Beam: A beam that runs unobstructed from the emitter to the receiver (same as a made or clear beam).



Banner Engineering Corp Limited Warranty

Banner Engineering Corp. warrants its products to be free from defects in material and workmanship for one year following the date of shipment. Banner Engineering Corp. will repair or replace, free of charge, any product of its manufacture which, at the time it is returned to the factory, is found to have been defective during the warranty period. This warranty does not cover damage or liability for misuse, abuse, or the improper application or installation of the Banner product.

THIS LIMITED WARRANTY IS EXCLUSIVE AND IN LIEU OF ALL OTHER WARRANTIES WHETHER EXPRESS OR IMPLIED (INCLUDING, WITHOUT LIMITATION, ANY WARRANTY OF MERCHANTABILITY OR FITNESS FOR A PARTICULAR PURPOSE), AND WHETHER ARISING UNDER COURSE OF PERFORMANCE, COURSE OF DEALING OR TRADE USAGE.

This Warranty is exclusive and limited to repair or, at the discretion of Banner Engineering Corp., replacement. **IN NO EVENT SHALL BANNER ENGINEERING CORP. BE LIABLE TO BUYER OR ANY OTHER PERSON OR ENTITY FOR ANY EXTRA COSTS, EXPENSES, LOSSES, LOSS OF PROFITS, OR ANY INCIDENTAL, CONSEQUENTIAL OR SPECIAL DAMAGES RESULTING FROM ANY PRODUCT DEFECT OR FROM THE USE OR INABILITY TO USE THE PRODUCT, WHETHER ARISING IN CONTRACT OR WARRANTY, STATUTE, TORT, STRICT LIABILITY, NEGLIGENCE, OR OTHERWISE.**

Banner Engineering Corp. reserves the right to change, modify or improve the design of the product without assuming any obligations or liabilities relating to any product previously manufactured by Banner Engineering Corp.



more sensors, more solutions