



The HN49U is a severe service union-bonnet needle valve that features a one-piece forged body and grafoil packing, all designed to handle the extreme conditions of high pressure and high temperature services such as those in super-heated steam power plant services.

With a multitude of configurations available, you will find a model to meet your varying needs. The HN49U is produced in 6mm and 10mm orifice sizes, and can be provided with tube socket weld or butt-weld end connections. To withstand the extreme temperatures this valve is designed for, the HN49U can be specified in either 316H or F91 materials.



Features and Benefits

- **Construction:** One-piece forged body design. Accidental valve disassembly prevented by union body construction. Packing able to be adjusted in the open position.
- **Packing Materials:** Grafoil packing standard to handle temperatures up to 1200°F (648,9°C).
- **Ratings:**
 - 10,000 psig @ 100°F (689,5 bar @ 37,8°C);
 - 3,500 psig @ 1200°F (241,3 bar @ 648,9°C)
- **Backseated Bonnets with Packing Below the Stem Threads:** To eliminate potential media contamination by the thread lubricant, the packing is located below the stem threads. Backseating minimizes potential leaking through the packing with a metal-to-metal backseat that also prevents stem blow-out during operation.
- **Standard Option:** Panel mounting standard on all HN49U valves.
- **Stem Design:** Non-Rotating Ball Tip Stem provides for repeatable, leak-tight shutoff. Because the ball stops rotating when it contacts the seat, further torque turns the stem, but not the ball tip, protecting the stem tip from damage.

Repeated closures improve the mating between the seat and the stem ball tip, unlike wear that will occur over time with a rotating tip.

- **Orifice Sizes:**
 - 0.236 in. (6,0 mm)
 - 0.394 in. (10,0 mm)

Flow Schematic



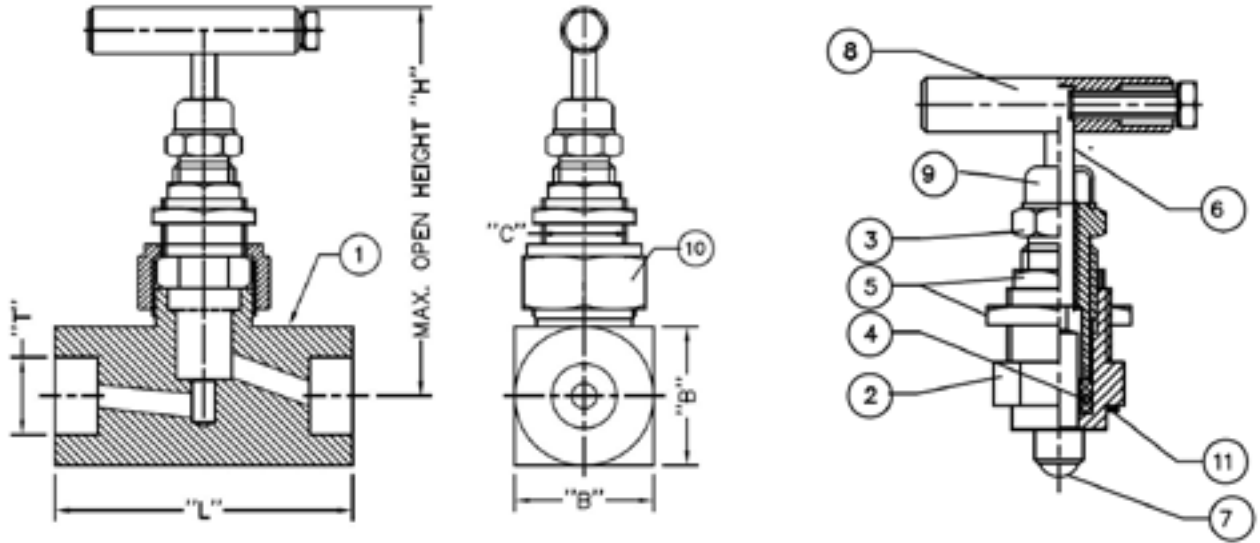

Part Descriptions

Part Number	Part Description	Quantity
1	Body	1
2	Gland Body	1
3	Gland Retainer	1
4	Gland Seal	2
5	Check Nut	1
6	Spindle	1
7	Ball Trim	1
8	Handle	1
9	Dust Cap	1
10	Union Bonnet Nut	1
11	Gland Washer	1

Dimensions

"I"	"B"	"L"	"C"	"H"	Orifice	Material
18.12	32.0	68.0	23.0	105.0	6.0	SS 316H/F91
18.12	35.0	78.0	25.0	115.0	10.0	SS 316H/F91

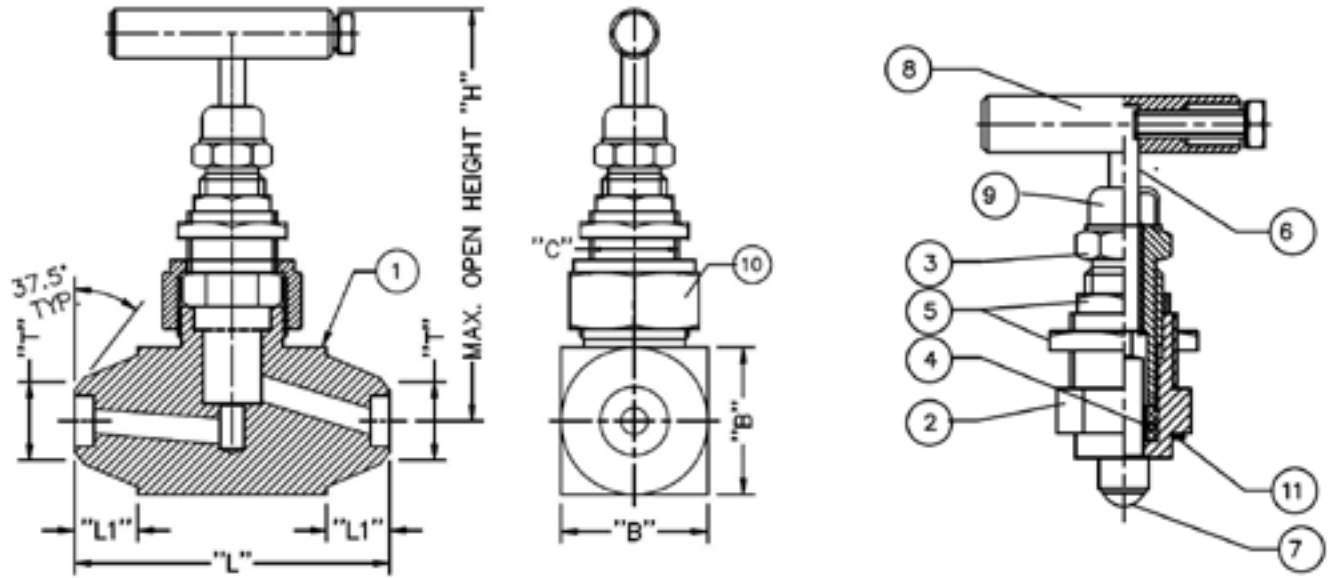

Part Descriptions

Part Number	Part Description	Quantity
1	Body	1
2	Gland Body	1
3	Gland Retainer	1
4	Gland Seal	2
5	Check Nut	1
6	Spindle	1
7	Ball Trim	1
8	Handle	1
9	Dust Cap	1
10	Union Bonnet Nut	1
11	Gland Washer	1

Dimensions

"I"	"B"	"L"	"L1"	"C"	"H"	Orifice	Material
18.12	32.0	68.0	12.0	23.0	105.0	6.0	SS 316H/F91
18.12	35.0	78.0	12.0	25.0	115.0	10.0	SS 316H/F91



Pressure and Temperature Chart

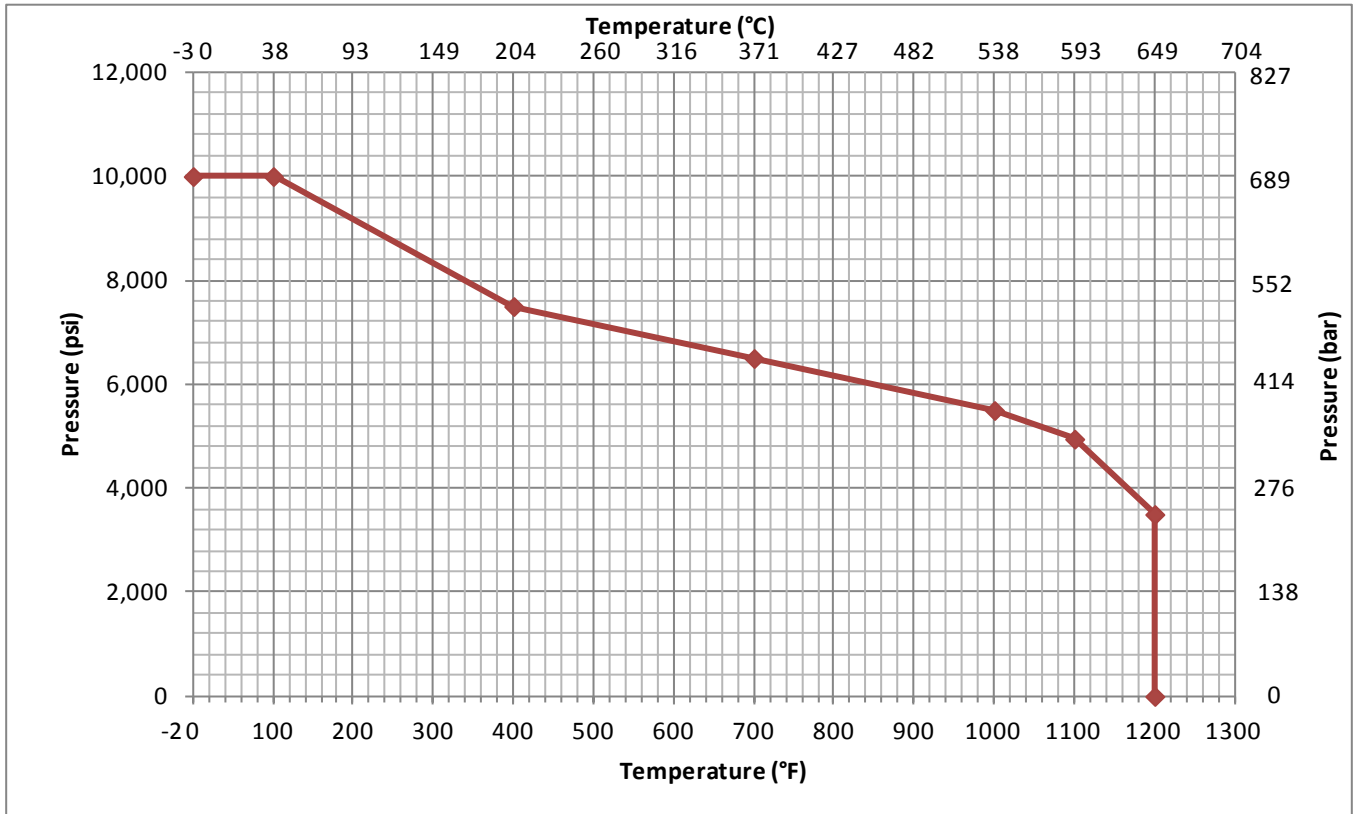

Note: If required pressure or temperature is beyond graph, consult factory.

How to Order

Model Number	Bonnet	Orifice Size	Body Material*	Inlet / Outlet Size†	Inlet / Outlet Type ‡
HN49U	U = Union Bonnet	A = 6mm	8 = 316H	I = 18mm	E = TSW
		B = 10mm	F = F91		1 = 4.5mm wall BWE

* Trim Material matches Body. Other materials available upon request.

† Other sizes available, consult factory.

‡ Other inlet/outlet types available, consult factory.

Sample Ordering Schematic

Example:	Model Number	Bonnet	Orifice Size	Body Material	Inlet / Outlet Size	Inlet / Outlet Type
	HN49	U	B	8	I	E