

Work Lights

Enclosure, Area and Spot Lighting

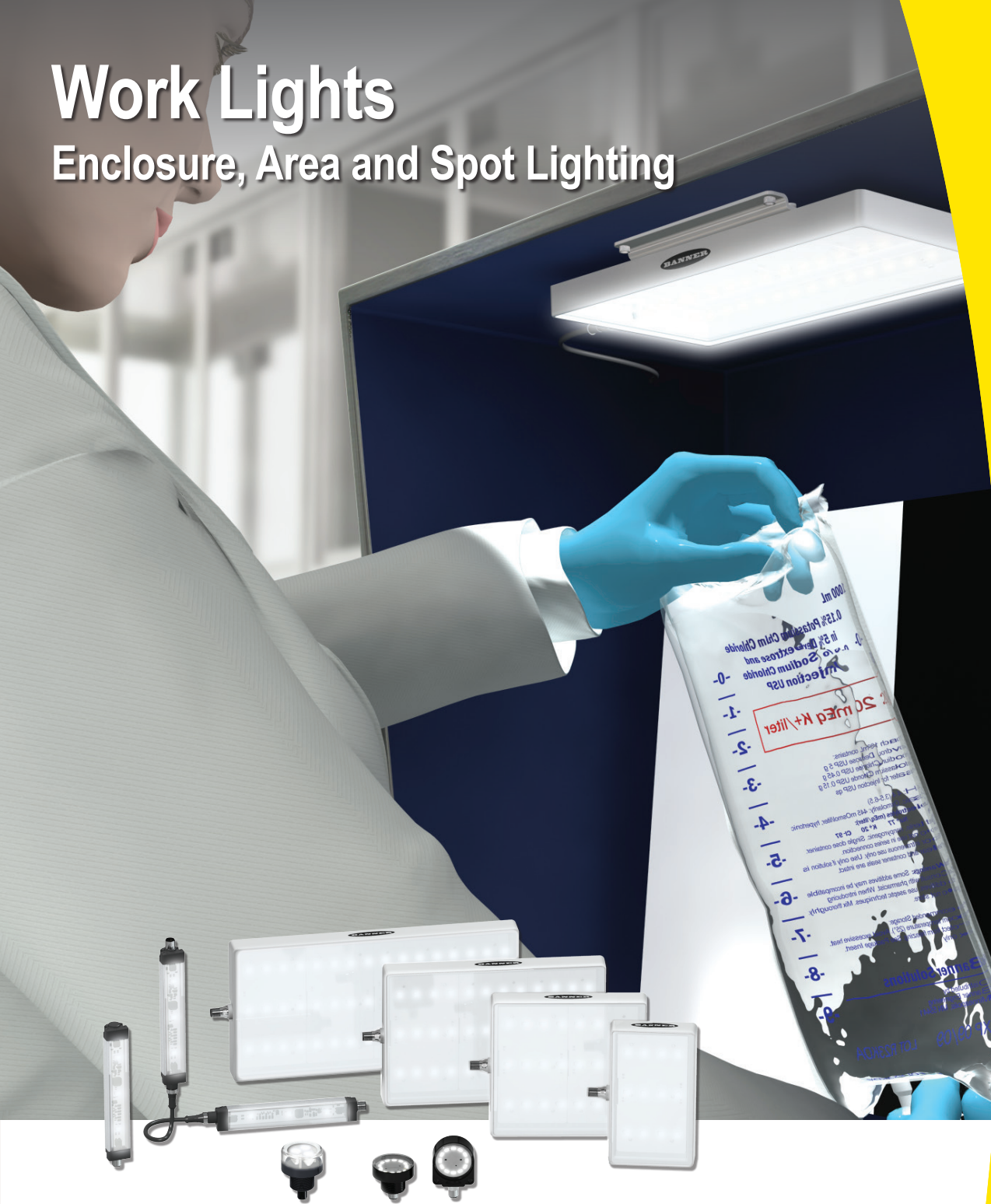

Simple and cost-effective task lighting

Banner Work Lights provide numerous solutions for illuminating work areas with intense, long-lasting and durable work lights. They are a simple, cost-effective, quality solution that are flexible in size and mounting. With the efficiency of LED long-lasting illumination, these work lights are an ideal replacement for fluorescent lighting.

- ▶ Energy-efficient LEDs produce three to four times more lumens per watt than incandescent bulbs
- ▶ Extremely bright LEDs last six times longer than CFLs and 40 times longer than incandescent light bulbs
- ▶ Simple, cost-effective, quality LEDs power up instantly for immediate use solutions
- ▶ Environmentally-friendly LEDs contain no mercury
- ▶ Banner LED lights have the same efficacy (lumens per watt) as fluorescents, but are more efficient in directing light to the work area
- ▶ Flexible in size and mounting

bannerengineering.com

BANNER[®]
more sensors, more solutions

WLS28-2 Work Light Strips

WLS28-2 work light strips provide bright, even, and efficient LED illumination for enclosures, machine lighting and work stations. The narrow profile metal housing allows lights to be mounted out of the way, while swivel brackets allow lights to be positioned exactly where needed. They are available in lengths from 145 mm to 1130 mm, and can be cascaded end-to-end to minimize wiring.

- Low-profile, 28 mm wide housing for use in industrial control cabinets or at work stations
- Rugged aluminum housing rated for IP50 (new models are available in waterproof housing rated IEC IP67 and IP69K)
- High-power LEDs for superior illumination with an even pattern of light and no shadows
- Swivel mounting brackets included
- Hi/Lo/OFF switch and non-switch models available
- Extremely long-lasting LED technology for greater than 50,000 hours of continuous working life
- Low power consumption; less than 9 watts per foot
- Cabled or quick-disconnect models for installation flexibility and convenient cascading of lights



Lumens* (Typical @ 25°C)

Length	Cool White
145	325
285	650
430	975
570	1300
710	1625
850	1950
990	2275
1130	2600

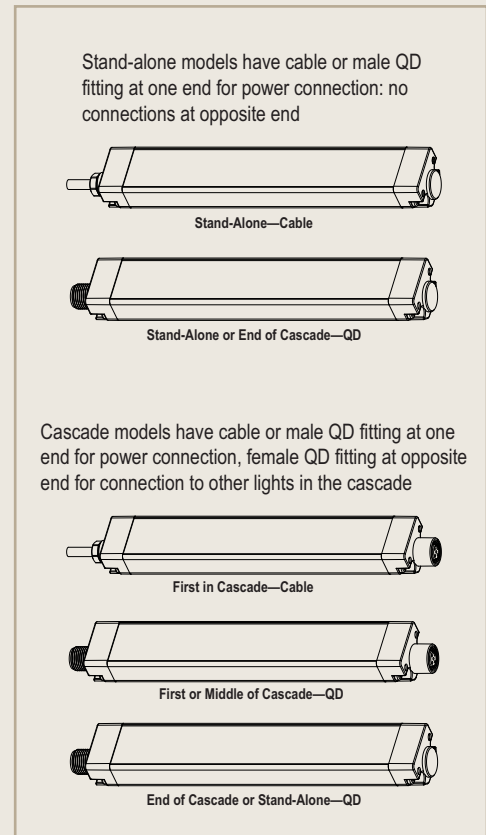
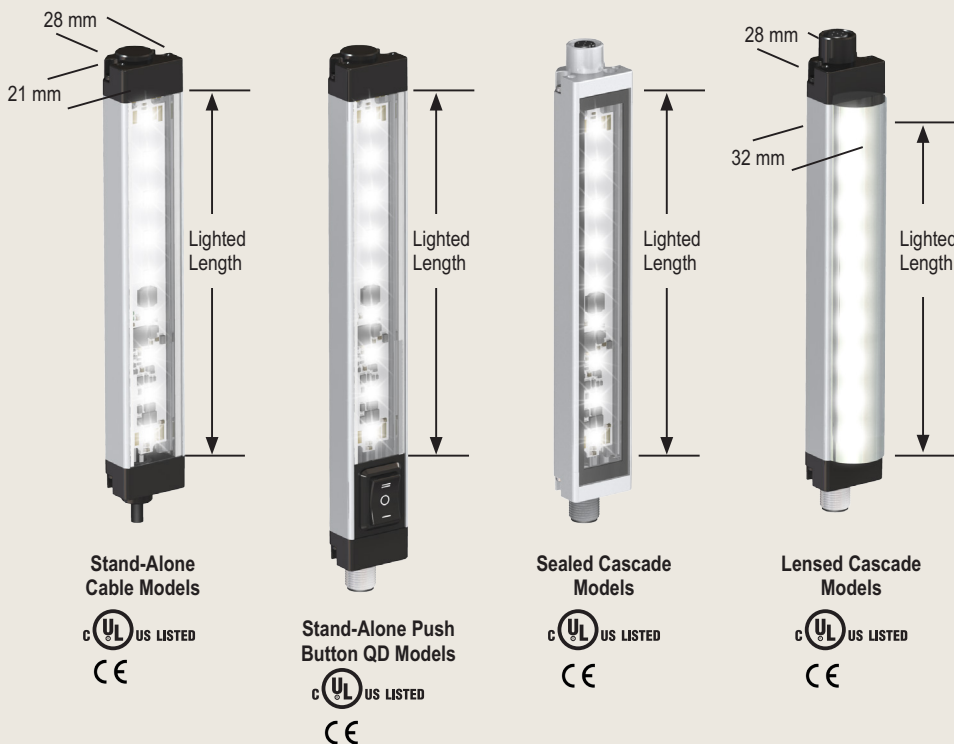
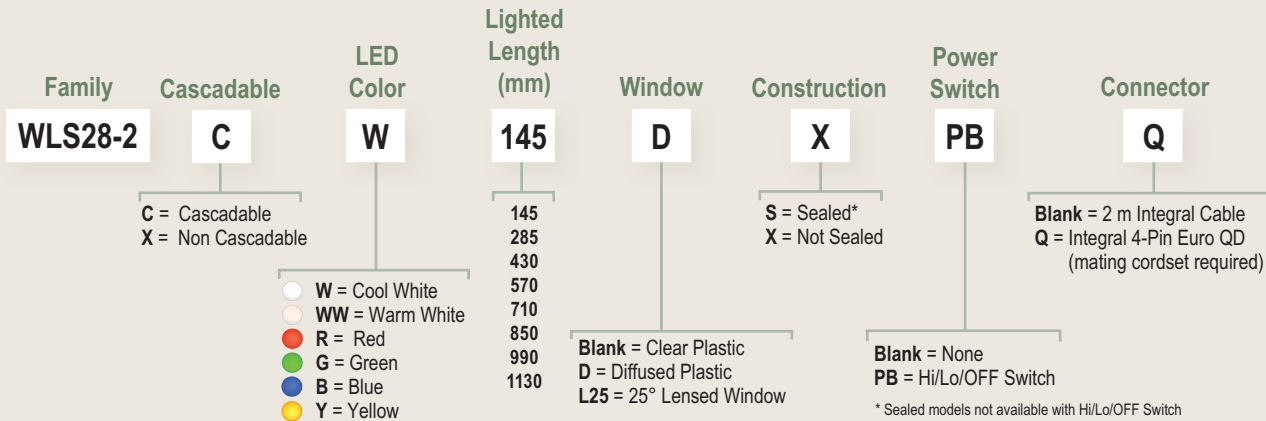

WLA Area Lights

WLA area lights are used in industrial work cells and areas exposed to liquids, such as food and beverage processing applications and machining centers. These rugged and energy-efficient work lights provide a bright, even pattern of cool white, warm white or colored light.

- High-power solid state LED array with cool white, warm white, red, green, blue or yellow light
- Illuminate a large area with an even pattern of light and no shadows
- Rugged thermoplastic housing rated to IP69K
- Encapsulated models available for enhanced resistance to chemicals, vibration and shock
- Available in four sizes
- Cabled and quick-disconnect models available
- Lensed models provide a concentrated, more intense beam pattern

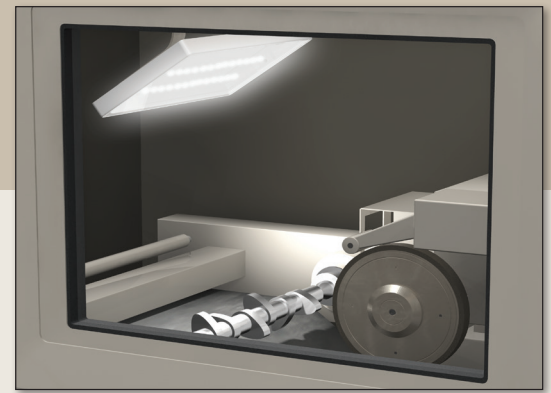

Lumens* (Typical @ 25°C)

Size	Cool White	Warm White	Green	Red	Yellow	Blue
105x180	650	515	385	145	325	110
190x180	1300	1030	770	290	650	220
275x180	1950	1545	1155	435	975	330
360x180	2600	2060	1540	580	1300	440

*Lumen values lowered by 35% on diffused windows models

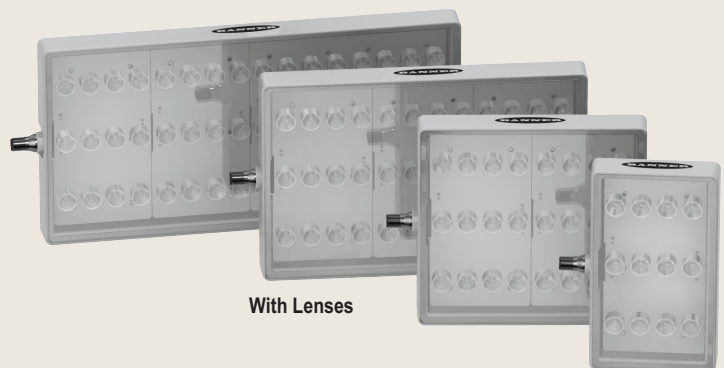
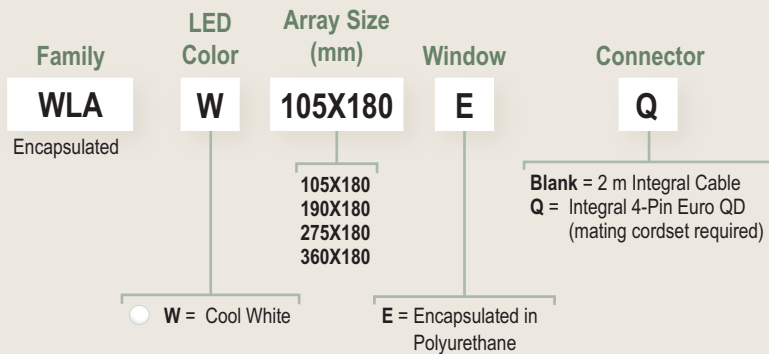
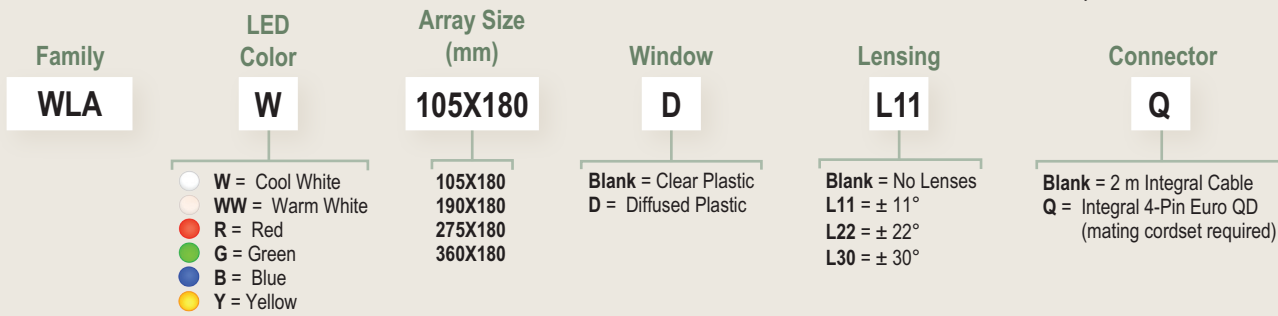

WL50-2 Work Lights

WL50 work lights provide bright, even illumination in areas where space is limited, including control cabinets and panels. The robust, sealed housing is ideal for lighting in wash-down and other rigorous industrial areas. Mounting on a flat surface is easy with the low-profile, flat-pack design and several mounting options.

- Extremely long-lasting LED technology for greater than 50,000 hours of continuous working life
- Low power consumption; less than 3 watts
- 12 to 30V dc operation
- Robust IP69K (standard) or IP67 (push-button models) for use in wet and dirty environments
- Shock, vibration and impact resistant
- Rugged, sealed polycarbonate housing

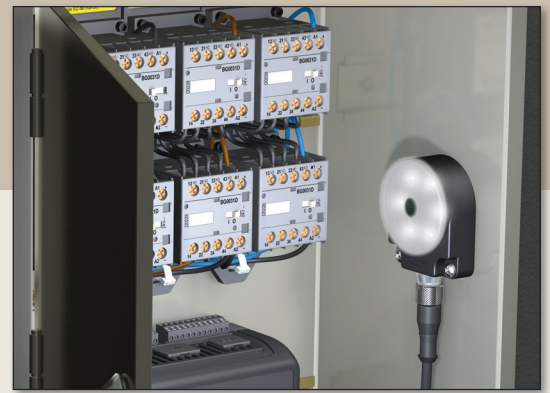

Lumens (Typical @ 25°C)

Cool White
185



Family

WL50-2

WL50-2 = 30 mm Mount
WL50F-2 = Flat Mount

Power Switch

PB

Blank = Standard
PB = ON/OFF Switch

Connector

Q

Blank = 2 m Integral Cable
Q = Integral 4-Pin Euro QD (mating cordset required)

Mounting Options

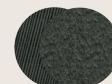

Velcro (included)

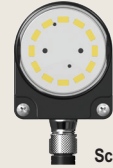

Screws

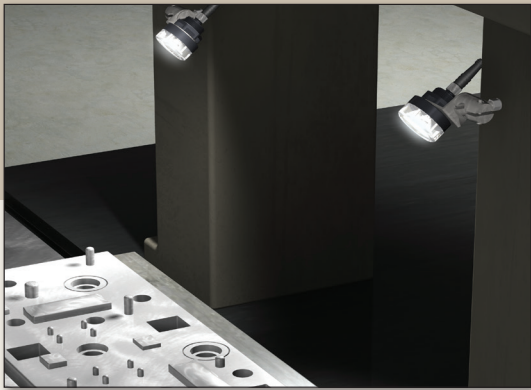

Lumens (Typical @ 25°C)

Lens	Cool White	Green	Red
±5°	295	210	110
±11°	285	200	105
±20°	270	190	100

WL50S Work Spot Lights

WL50S work spot lights illuminate a specific area with an even pattern of light and no shadows. Three versions of lens angles are available to ensure the area of concentration is covered. With three high-intensity LEDs, the WL50S work spot lights create impeccable illumination for use in specific work areas.

- Highly concentrated, focused light available in white, red and green
- Rugged sealed housing rated to IP69K
- 12 to 30V dc operation
- Cabled and quick-disconnect models available
- 50 mm diameter with a threaded 30 mm mounting base

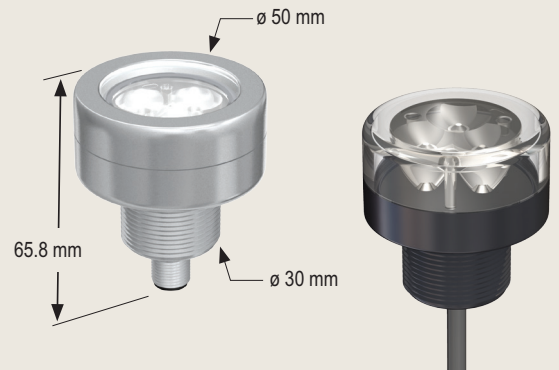

Family

WL50S

LED Color

W

- W = White
- G = Green
- R = Red

Lens Angle

L11

- L5 = ±5° (small)
- L11 = ±11° (large)
- L20 = ±20° (largest)

Connector

Q

Blank = 2 m Integral Cable
Q = Integral 4-Pin Euro QD (mating cordset required)

Family

WL50S

LED Color

W

- W = White
- G = Green
- R = Red

Housing

SS

SS = Stainless Steel

Window Material

G

Blank = Acrylic
G = Glass

Lens Angle

L11

- L5 = ±5° (small)
- L11 = ±11° (large)
- L20 = ±20° (largest)

Connector

Q

Blank = 2 m Integral Cable
Q = Integral 4-Pin Euro QD (mating cordset required)

Cordsets

Quick-Disconnect Cordsets—Double-Ended

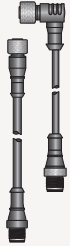

Model		Connection	Length	Used With
Straight/ Straight	Straight/ Right-Angle			
MQDEC-401SS	MQDEC-401RS	4-pin Euro-style	0.3 m	WLS28-2
MQDEC-403SS	MQDEC-403RS		0.91 m	
MQDEC-406SS	MQDEC-406RS		1.83 m	
MQDEC-412SS	MQDEC-412RS		3.66 m	
MQDEC-420SS	MQDEC-420RS		6.10 m	
MQDEC-430SS	MQDEC-430RS		9.14 m	
MQDEC-450SS	MQDEC-450RS		15.2 m	

Quick-Disconnect Cordsets

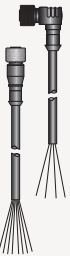

Model		Connection	Length	Used With
Straight	Right-Angle			
MQDC-406	MQDC-406RA	4-pin Euro-style	1.83 m	WL50
MQDC-415	MQDC-415RA		4.57 m	WLS28-8 WLA
MQDC-430	MQDC-430RA		9.14 m	WL50S

Quick-Disconnect Cordsets—Splitter



Model	Connection	Length		Used With
		Branches	Trunk	
CSB-M1240M1240	4-pin Euro-style	0 m	0 m	WL50 WLS28-2 WLA
CSB-M1240M1241		0.30 m	0 m	
CSB-M1241M1241		0.30 m	0.30 m	
CSB-M1248M1241		0.30 m	2.50 m	
CSB-M12415M1241		0.30 m	4.60 m	
CSB-M12425M1241		0.30 m	7.60 m	
CSB-UNT425M1241		0.30 m	7.60 m	

Additional Mounting Options

Description	
	SMBWLSMAG (Use with WLS28-2) Includes: 2 magnets, 2 M5 screws, 2 M5 nuts with lock rings
	SMBWLSMAGR (Use with WLS28-2) 2 rubber covers to prevent scratching
	SMBWLAMAG (Use with WLA) Includes: 4 magnets, 4 M5 screws
	SMBWLAMAGR (Use with WLA) 4 rubber covers to prevent scratching
	SMH1316 (use with WLS28-2) Allows the light to be mounted to a 13/16" Unistrut channel. The kit includes: • 2 X 10-32 spring nuts • 2 X 10-32 socket head cap screws • 2 X #10 lock washers

Brackets

Description	
<p>Use with: WL50, WL50S</p>	SMB30A • Curved slot for versatile orientation • 12-ga. stainless steel • 30 mm mounting hole
<p>Use with: WL50S</p>	SMB30FA • Swivel bracket with tilt and pan movement for precision adjustment • 30 mm mounting hole • Easy sensor mounting to extruded rail T-slot
<p>Use with: WL50, WL50S</p>	SMB30MM • Curved slots for versatility and orientation • 12-ga. stainless steel • 30 mm mounting hole
<p>Use with: WL50, WL50S</p>	SMB30SC • Swivel bracket with 30 mm mounting hole • Black reinforced thermoplastic polyester • Stainless steel mounting and swivel hardware included
<p>Use with: WL50S</p>	SMBAMS30P • Articulation slot for 90+° rotation • 12-ga. cold-rolled steel • 30 mm mounting hole
<p>Use with: WL50S</p>	SMBAMS30RA • Articulation slot for 90+° rotation • 12-ga. cold-rolled steel • 30 mm mounting hole
<p>Use with: WLS28-2</p>	SMBWLS28RA • Two replacement brackets for one light • 14-ga. zinc-plated steel • ± 45° rotation from center
<p>Use with: WLS28-2</p>	SMBWLS28SM • 14-ga. zinc-plated steel • ± 30° rotation from center
<p>Use with: WLA</p>	SMBBSSM • Set of two surface-mount brackets • 316 stainless steel hardware included
<p>Use with: WLA</p>	SMBBSRA • Swivel bracket for versatile orientation • 316 stainless steel bracket and hardware



FLX18 Flex Arm Mounts

Provide versatile mounting options to easily direct lighting where it is needed, whether in a work station or along a manufacturing line. Available for use with spot lights, work lights and vision spot lights.

Banner service and support

Industry experts and solutions for a wide range of applications across many industries



- Agriculture
- Assembly
- Automotive
- Food & Beverage
- Material Handling
- Packaging
- Pharmaceutical & Medical
- Process & Chemical
- Robotics
- Semiconductor
- Traffic
- Warehouse & Distribution

Contact a Banner Engineer about your application. Our highly skilled application engineers and industry experts are ready to support you wherever you are—worldwide.

www.bannerengineering.com • 1-888-373-6767

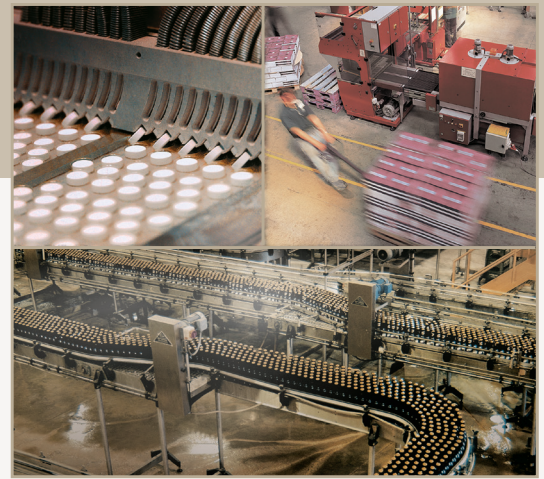

Access to the latest products and information anytime



Visit our online resource center
 Latest products
 Technical information
 Product literature
 Application examples

Find a distributor near you

Banner Insider eNewsletter
 Subscribe now for new product updates, helpful application information, answers to frequently asked questions and other valuable information at www.bannerengineering.com/insider



More products, more solutions in Banner's latest product catalog

Download or request a catalog online at www.bannerengineering.com/catalog or call 1.888.373.6767



For technical information



Banner Engineering Corp.

9714 Tenth Avenue North • Minneapolis, Minnesota 55441 • (763) 544-3164 • Fax: (763) 544-3213
 Toll-free: 888-373-6767 • www.bannerengineering.com • Email: sensors@bannerengineering.com

www.bannerengineering.com

