

VE Series LED High-Intensity Ring Light

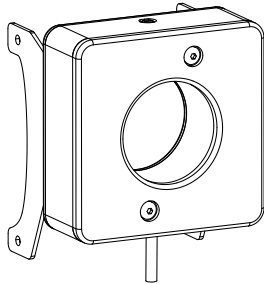

Datasheet

High-Intensity LED Ring Light for use with VE Series vision sensors



- Compact ring light for VE Series vision sensors
- Four extremely bright LEDs for illumination of targets from 0.15 meters to beyond 2 meters (0.49 feet to 6.56 feet)
- Continuous or strobed operation
- Optically isolated strobe signal
- Fixed or adjustable intensity, depending on model
- Maintenance-free, rugged construction
- Evenly and intensely illuminates a 610 millimeters (24 inches) diameter at 1 meter (3.28 feet)

Models

Model	LED Color	Intensity Adjustment	Connection
LEDRRV70XD5-XM	Visible red, 620 nm to 630 nm	Fixed	300 mm (12 in) cable with a threaded 3-pin Pico-style connector ¹
LEDWRV70XD5-XM	White, 5000 K to 8300 K		
LEDBRV70XD5-XM	Visible blue, 465 nm to 485 nm		
LEDGRV70XD5-XM	Visible green, 520 nm to 535 nm		
LEDIRV70XD5-XM	Infrared, 850 nm		
LEDUV395RV70XD5-XM	Ultraviolet, 395 nm		
LEDRRV70XD5-PM	Visible red, 620 nm to 630 nm	Potentiometer	
LEDWRV70XD5-PM	White, 5000 K to 8300 K		
LEDBRV70XD5-PM	Visible blue, 465 nm to 485 nm		
LEDGRV70XD5-PM	Visible green, 520 nm to 535 nm		
LEDIRV70XD5-PM	Infrared, 850 nm		
LEDUV395RV70XD5-PM	Ultraviolet, 395 nm		

The following caution applies to ultraviolet, 395 nm models:



CAUTION:

Risk Group 2: UV Emitted from this product.

Eye or skin irritation may result from exposure. Use appropriate shielding and eye protection. Risk Group 2 (RG 2) products generally do not pose a realistic optical hazard if aversion responses limit the exposure duration or where lengthy exposures are unrealistic.

- IEC 62471



NOTE: Ring lights are not compatible with VELC... Sealed Lens Covers. Use another lighting technique if an IP67 rating is needed for your application.

Install the Ring Light

1. Attach the ring light bracket to the sides of the VE Series vision sensor using the provided hardware kit.
2. Connect the cable to the sensor.

Light Intensity Adjustment

Turn the 270° intensity potentiometer with a small flat-blade screwdriver to adjust the light's intensity.

1. Apply power to the light and turn the potentiometer all the way clockwise for maximum intensity.
2. If the object to be sensed is too bright at maximum intensity, turn the potentiometer counterclockwise, a little at a time, testing with the target object, until the correct brightness is achieved.

¹ Connects directly to the VE Series vision sensors



Specifications

Light Source

Four high-intensity LEDs: see models table for wavelengths

Illumination

610 mm (24 in) diameter usable light pattern at 1 m (3.28 ft)

Strobe

Optically isolated

Supply Voltage and Current

Operating Voltage: 24 V dc $\pm 10\%$

Strobe Voltage: 5 V dc to 24 V dc @ 15 mA maximum

Current Draw at Full Intensity: 350 mA maximum

Built-in constant current regulator for LEDs

Potentiometer controls variable intensity for "P" models

Strobe Type

Active low

Connection

300 mm (12 in) cable with a threaded 3-pin Pico-style connector

Construction

Housing: Aluminum, black anodized

Window: Acrylic, clear with frosted diffusing surface on inside

Bracket: Cold-rolled steel with black gloss e-coat plating. Attaches the ring light directly to the VE 200 Series vision sensor with four included M3 x 6 mm screws

Useful Life

When operated within specifications, output decreases less than 30% after 50,000 hours for visible and IR models, 20,000 hours for UV models

Operating Conditions

Temperature: 0 °C to +50 °C (+32 °F to +122 °F)

Humidity: 90% maximum relative humidity (non-condensing)

Environmental Rating

IEC IP50

Certifications



Light Characteristics

Values shown are typical @ 25°C.

	Lumens				mWatts	
	Cool White	Green	Red	Blue	IR	UV395
LEDxR70	390	340	240	130	945	475

Optical Data

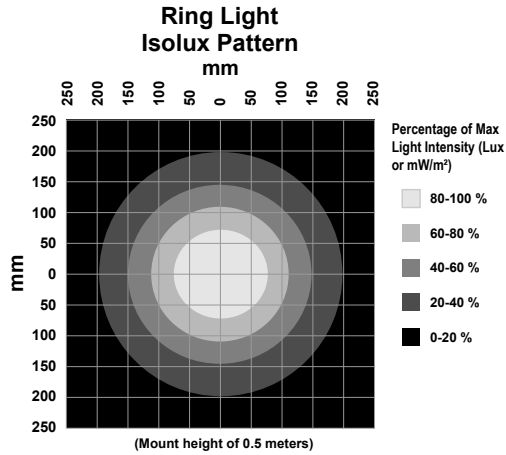

Values shown are typical at 25 °C.

Distance (m)	Max Center Beam Lux (lux)				Max Center Beam Irradiance (mW/m ²)		Beam Width (m)	
	Cool White	Green	Red	Blue	IR	UV395	Vertical (Spread 29.6°)	Horizontal (Spread 28.4°)
0.25	16,620	14,489	10,228	5,540	40,272	20,242	0.13	0.13
0.50	5,150	4,490	3,169	1,717	12,479	6,272	0.26	0.25
1.00	1,125	981	692	375	2,726	1,370	0.53	0.51

Dimensions

All measurements are listed in millimeters [inches], unless noted otherwise.

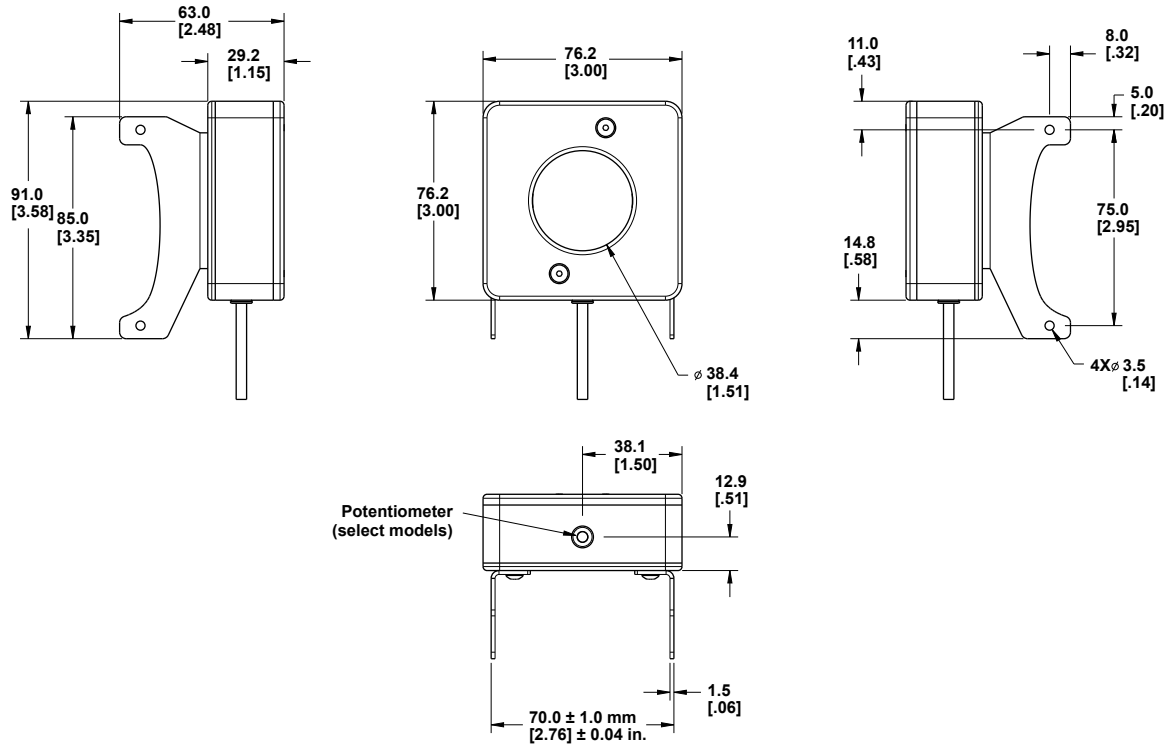

Clean the Light

Regularly remove dust, dirt, or fingerprints from the light source.

1. Blow off dust using anti-static compressed air.
2. If necessary, use a lens cloth and lens cleaner or window cleaner to wipe off remaining debris.



Important: Do not use any other chemicals for cleaning the light source.

Banner Engineering Corp. Limited Warranty

Banner Engineering Corp. warrants its products to be free from defects in material and workmanship for one year following the date of shipment. Banner Engineering Corp. will repair or replace, free of charge, any product of its manufacture which, at the time it is returned to the factory, is found to have been defective during the warranty period. This warranty does not cover damage or liability for misuse, abuse, or the improper application or installation of the Banner product.

THIS LIMITED WARRANTY IS EXCLUSIVE AND IN LIEU OF ALL OTHER WARRANTIES WHETHER EXPRESS OR IMPLIED (INCLUDING, WITHOUT LIMITATION, ANY WARRANTY OF MERCHANTABILITY OR FITNESS FOR A PARTICULAR PURPOSE), AND WHETHER ARISING UNDER COURSE OF PERFORMANCE, COURSE OF DEALING OR TRADE USAGE.

This Warranty is exclusive and limited to repair or, at the discretion of Banner Engineering Corp., replacement. IN NO EVENT SHALL BANNER ENGINEERING CORP. BE LIABLE TO BUYER OR ANY OTHER PERSON OR ENTITY FOR ANY EXTRA COSTS, EXPENSES, LOSSES, LOSS OF PROFITS, OR ANY INCIDENTAL, CONSEQUENTIAL OR SPECIAL DAMAGES RESULTING FROM ANY PRODUCT DEFECT OR FROM THE USE OR INABILITY TO USE THE PRODUCT, WHETHER ARISING IN CONTRACT OR WARRANTY, STATUTE, TORT, STRICT LIABILITY, NEGLIGENCE, OR OTHERWISE.

Banner Engineering Corp. reserves the right to change, modify or improve the design of the product without assuming any obligations or liabilities relating to any product previously manufactured by Banner Engineering Corp. Any misuse, abuse, or improper application or installation of this product or use of the product for personal protection applications when the product is identified as not intended for such purposes will void the product warranty. Any modifications to this product without prior express approval by Banner Engineering Corp will void the product warranties. All specifications published in this document are subject to change; Banner reserves the right to modify product specifications or update documentation at any time. Specifications and product information in English supersede that which is provided in any other language. For the most recent version of any documentation, refer to: www.bannerengineering.com.