

DIN MUTING MODULE

Types

MMD-TA-11B & MMD-TA-12B

For use with EZ-SCREEN® OSSD outputs, MINI-SCREEN®, MICRO-SCREEN®, MACHINE-GUARD™ or other safety devices with hard relay contact safety output(s) or +24 VDC (PNP) outputs

Instruction Manual

European UK English Version

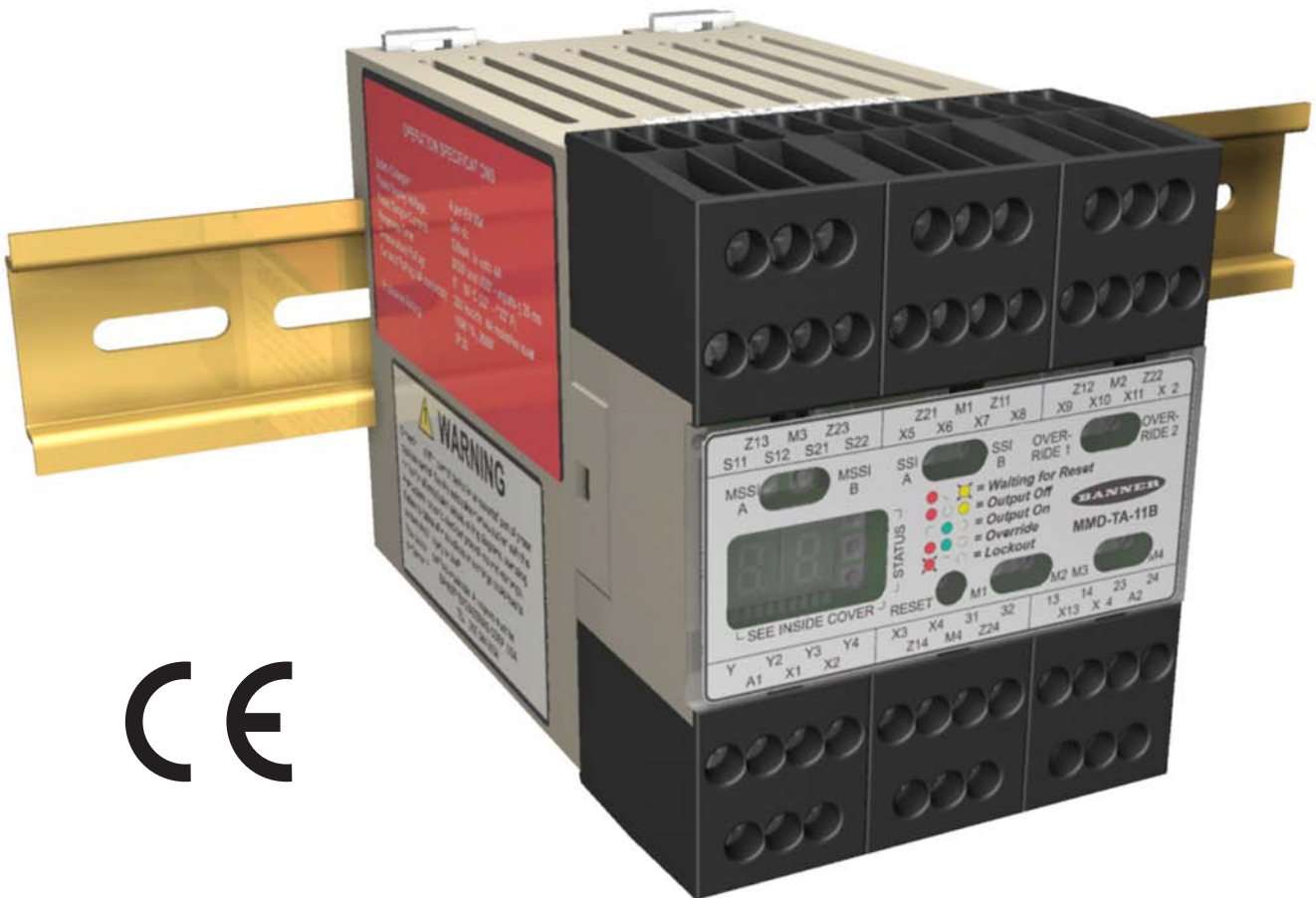

CE



more sensors, more solutions

All rights reserved.

No part of this publication may be reproduced or transmitted, in any form or by any means, without prior written permission.

© - Banner Engineering Corp., 9714 10th Avenue North, Minneapolis, MN 55441, USA.

132538 08.08.07

Intentionally left blank

Contents

1 SAFETY	1
1.1 SAFETY NOTICES	1
1.1.1 Types	1
1.1.1.1 Warnings	1
1.1.1.2 Cautions	1
1.1.1.3 Notes	1
1.2 PRODUCT SAFETY LABELLING INFORMATION	1
1.3 WARNINGS & NOTES IN THE MANUAL	1
1.4 SAFETY STANDARDS & EN DIRECTIVES	2
1.5 INGRESS PROTECTION RATINGS	2
1.6 ELECTRICAL SAFETY	2
1.7 CONDITIONS OF EQUIPMENT USE	3
1.7.1 Appropriate Applications	3
1.7.2 Non-Appropriate Applications	3
1.8 SECURITY PROTOCOL	3
1.9 DESIGNATED & QUALIFIED PERSONS	3
1.9.1 Designated Person	3
1.9.2 Qualified Person	3
1.10 CONTROL RELIABILITY	4
1.10.1 Redundancy & Self-Checking	4
1.11 DIN Muting Module(s) SAFETY FEATURES	4
1.11.1 Automatic or Monitored Manual Reset Select	4
1.11.1.1 Monitored Manual Reset	4
1.11.1.2 Automatic Reset	4
1.11.2 Lockout Conditions	4
1.11.3 Mutable Safety Stop Interface & Safety Safety (Protective) Stop Interface	5
1.11.3.1 Mutable Safety Stop Interface (MSSI)	5
1.11.3.2 Safety (Protective) Stop Interface (SSI)	5
1.11.4 Output Signal Switching Device (OSSD) Outputs	5
1.11.5 Auxiliary (Aux) Output	5
1.11.6 External Device Monitoring (EDM)	6
1.11.6.1 One Channel Monitoring	6
1.11.6.2 Two Channel Monitoring	6
1.11.6.3 No Monitoring	6
1.11.7 Mute Devices & Mute Inputs (M1-M4)	6
1.11.7.1 The Muting Function	6
1.11.7.2 Mute Devices	6
1.11.8 Mute Enable (ME)	7
1.11.8.1 Simultaneity Timer Reset Function	7
1.11.9 Mute Lamp Output (ML)	7
1.11.10 Mute On Power-Up	7
1.11.11 Override	8
1.11.12 One Way/Two Way Muting	8
1.11.13 Use of Corner Mirrors with Optical Safety Systems	8

Contents (cont'd)

1.11.14 PSSDs	8
1.11.15 Pass-Through Hazards	8
1.11.16 FSD Interfacing Connections	9
1.11.16.1 Safety (Protective) Stop Circuits	9
1.11.16.2 Dual-Channel Control	9
1.11.16.3 Single-Channel Control	9
1.12 DISCLAIMER INFORMATION	10
1.13 EQUIPMENT NOISE LEVELS	10
1.14 EQUIPMENT VIBRATION LEVELS	10
1.15 EQUIPMENT RADIATION LEVELS	10
1.15.1 Electromagnetic Immunity Levels	10
2 INTRODUCTION	11
2.1 PRODUCT FEATURES	11
2.2 ABOUT THIS MANUAL	11
2.3 SYSTEM DESCRIPTION	12
2.3.1 Operating LEDs & Diagnostic Display	12
2.3.2 Typical Muting Applications	13
2.3.2.1 Entry/Exit Applications	13
2.3.2.2 Robot Load/Unload Station Application	13
2.3.2.3 Home or Station Application	13
2.3.2.4 Turret Table Application	13
2.3.2.5 Power Press Application	13
3 GENERAL	15
3.1 PRODUCT	15
3.1.1 CE Marking / Product Identification Plate	15
3.1.2 Certificate of Adequacy	15
3.1.3 Declaration of Conformity	16
3.2 TECHNICAL DATA	17
3.2.1 Specifications	17
3.2.2 Model/Type Numbering	19
3.2.2.1 DIN Muting Module Model/Type Numbering	19
3.2.3 DIN Muting Module Dimensions	20
3.3 CUSTOMER SERVICE INFORMATION	20
4 INSTALLATION	21
4.1 PRE-INSTALLATION CONSIDERATIONS	21
4.1.1 Reducing or Eliminating Pass-Through Hazards	21
4.2 INSTALLING THE DIN MUTING MODULE(S)	21
4.3 DIN MUTING MODULE(S) CONFIGURATION	22
4.4 TERMINAL BLOCK CONNECTION & FUNCTIONS	23
4.5 CONNECTING INPUT DEVICES	25
4.5.1 Manual Reset Switch	25
4.5.1.1 Reset Routine	25
4.5.2 Muting Devices	25

Contents (cont'd)

4.5.2.1 General Muting Device Requirements	25
4.5.2.2 Examples of Muting Sensors & Switches	25
4.5.2.3 Muting Device Connection	25
4.5.3 Mute Lamp Output & Auxiliary Output	25
4.5.3.1 Mute Lamp Output (ML)	25
4.5.3.2 Auxiliary Output (AUX)	26
4.5.4 Override Switch Connection	26
4.5.5 SSI & MSSSI Interfacing	26
4.5.5.1 Safety Circuit Integrity & ISO 13849-1 (EN954-1)	26
4.5.5.2 Generic SSI & MSSSI Connection	27
4.5.5.3 SSI Emergency Stop (E-STOP) Switch Connection	28
4.5.5.4 SSI/MSSSI Interlocked Guard or Safety Gate Connection	29
4.5.5.5 SSI Supplementary Safety System Connection	30
4.6 INITIAL CONNECTION & CHECKOUT	31
4.6.1 GENERAL	31
4.6.2 Preparation	31
4.6.3 Initial Procedure	31
4.7 PERMANENT ELECTRICAL CONNECTION	33
4.7.1 Mute Enable (ME) Connection	33
4.7.2 EXTERNAL DEVICE MONITORING (EDM) Connection	33
4.7.3 OSSD Output Connections	34
4.7.4 FSD Interfacing Connections	34
4.8 COMMISSIONING CHECKOUT	35
4.8.1 Preparation	35
4.8.2 Safeguarding Device(s) Checkout	35
4.8.3 Muting Checkout	36
5 OPERATING	37
5.1 EQUIPMENT INDICATION & CONTROLS	37
5.1.1 Indications	37
5.1.2 Controls	37
5.1.2.1 Backdoor Timer	37
5.1.2.2 Manual Key Reset Switch (optionally supplied)	38
5.1.2.3 E-Stop Switch (optionally supplied)	38
5.2 NORMAL OPERATION	38
5.2.1 General	38
5.2.2 Normal Start-up	38
5.2.3 Running Procedures	38
5.2.3.1 Responding to a Lockout Condition	38
5.2.4 Shutdown Procedure	38
6 MAINTENANCE	39
6.1 PREVENTIVE MAINTENANCE	39
6.1.1 Warranty Service	39
6.1.2 Periodic Checkout Requirements	39

Contents (cont'd)

6.1.3 Schedule of Check-outs	39
6.1.3.1 Initial Checkout	39
6.1.3.2 Commissioning Checkout	39
6.1.3.3 Daily Checkout	39
6.1.3.4 Six Monthly Checkout	39
6.1.4 Initial Checkout	39
6.1.5 Commissioning Checkout	39
6.1.6 Daily/Shift Change Checkout	41
6.1.7 Six Monthly Checkout	43
6.1.7.1 Preparation	43
6.1.7.2 Safeguarding Device(s) Checkout	43
6.1.7.3 Muting Checkout	44
6.1.7.4 General	44
6.2 CORRECTIVE MAINTENANCE	45
6.2.1 Trouble Shooting	45
6.2.1.1 Lockout Conditions	45
6.2.1.2 Diagnostic Display	45
6.2.1.3 Effects of Electrical Noise	46
6.2.1.4 Circuit & Wiring Information	46
6.2.1.5 Repairs	46
6.3 SPARE PARTS	47
A1 WIRING & SCHEMATIC DIAGRAMS	49
A1.1 WARNINGS FOR WIRING & SCHEMATIC DIAGRAMS	49
A2 MUTE TIMING SEQUENCES	59
A3 TYPICAL MUTING APPLICATIONS	61
A4 GLOSSARY & ABBREVIATIONS	65
A5 CUSTOMER INFORMATION	69

List of Figures

Figure 1 Typical Reset Switch	4
Figure 2 DIN Muting Module Types MMD-TA-11B & -12B Display Layout	12
Figure 3 DIN Muting Module Type MMD-TA-11B & -12B CE Marking / Production Identification Plate	15
Figure 4 Declaration of Conformity for DIN Muting Module Type MMD-TA-11B & -12B	16
Figure 5 Declaration of Conformity for DIN Muting Module Type MMD-TA-11B & 12B Translated Version	16
Figure 6 DIN Muting Module MMD-TA-11B & -12B Dimensions	20
Figure 7 DIN Muting Module MMD-TA-11B & -12B Dip Switches Settings	22
Figure 8 DIN Muting Module Terminal Blocks Extended	23
Figure 9 Status Indicators & Diagnostic Display	37
Figure 10 E-Stop Switch	38
Figure 11 DIN Muting Module Types MMD-TA-11B and -12B with User Supplied Safety Light Screen Guarding System Schematic Layout	49
Figure 12 DIN Muting Module Generic Machine Interface Connection Module MMD-TA-12B, FSD with Two-Channel EDM	50
Figure 13 DIN Muting Module Generic Machine Interface Connection Module MMD-TA-12B, Interface Module with Two-Channel EDM	51
Figure 14 DIN Muting Module Generic Machine Interface Connection Module MMD-TA-12B, Interface Module with One-Channel EDM	52
Figure 15 DIN Muting Module Generic Machine Interface Connection, Model MMD-TA-11B: MPCE with 2-channel EDM ..	53
Figure 16 DIN Muting Module Generic Machine Interface Connection, Model MMD-TA-11B: MPCE with 1-channel EDM ..	53
Figure 17 Manual Reset Switch Connections	53
Figure 18 Relay (Hard Contact) Output Sensors	53
Figure 19 Four Limit Switches as M1, M2, M3 & M4	53
Figure 20 Two (or Four) Sensors Using Semiconductor Outputs	54
Figure 21 Mute Lamp Output Connections	54
Figure 22 AUX Output Connection – MMD-TA-11B	54
Figure 23 AUX Output Connection – MMD-TA-12B	54
Figure 24 Override Switch Connections	54
Figure 25 Interfacing Supplementary Safeguarding to Prevent Personnel from Entering the Hazardous Area During the Mute	55
Figure 26 MSSl & SSl Category 2 Interfacing: Positive Opening Switch	56
Figure 27 MSSl & SSl Category 2 Interfacing: Category 2 Safeguarding Device (for example EZ-SCREEN Type 2 or AOPD Type 2 per IEC 61496-1/-2)	56
Figure 28 MSSl & SSl Category 3 Interfacing: Two Positive Opening Switches per Single Guard	56
Figure 29 MSSl & SSl Category 3 Interfacing: Category 3 Safeguarding Device with Output Fault Monitoring (for example Type 3 Area Scanner AOPDDR per IEC 61496-1/-3)	56
Figure 30 MSSl & SSl Category 4 Interfacing: Two Positive-opening Switches Per Single Guard	56
Figure 31 MSSl & SSl Category 4 Interfacing: Category 4 Safeguarding Device with Output Fault Monitoring (for example EZ-SCREEN or AOPD Type 4 per IEC 61496-1/-2)	56
Figure 32 MSSl & SSl Category 4 Interfacing: Category 4 Safeguarding Device with Relay Outputs (for Example MINI-SCREEN or AOPD Type 4 per IEC 61496-1/-2)	57
Figure 33 SSl Category 2 Interfacing: Positive Opening E-Stop Switch(es)	57
Figure 34 SSl Category 3 Interfacing: Positive Opening E-Stop Switch(es)	57
Figure 35 SSl Category 4 Interfacing: Positive Opening E-Stop Switch(es)	57

List of Figures (cont'd)

Figure 36 MSSl or SSl Category 2 Interfacing: Positive Opening	57
Figure 37 MSSl or SSl Category 3 Interfacing: Positive Opening Interlocking Switch(es)	58
Figure 38 SSl Category 4 Interfacing: Positive Opening Interlocking Switch(es)	58
Figure 39 Mute Enable Connection	58
Figure 40 Muting Sequence with Two Devices	59
Figure 41 Muting Sequence with Four Devices	60
Figure 42 X-Pattern Entry/Exit System Using Two Pairs of Opposed-Mode Photoelectric Muting Devices	61
Figure 43 Horizontal Photoelectric Muting Devices Placed at Different Heights	61
Figure 44 Photoelectric Muting Devices Placed Diagonally	61
Figure 45 Entry/Exit System Using Whisker/Limit Switches as Muting Devices	62
Figure 46 An Entry/Exit System Using Four Photoelectric Sensors as M1, M2, M3 and M4	62
Figure 47 Robot Load/Unload Application with Two-Station Home-Position Muting, Using Polarized Retro Reflective Photoelectrics as Muting Devices	63

List of Tables

Table 1 Label Identification DIN Muting Module	1
Table 2 DIN Muting Module General Specifications	17
Table 3 DIN Muting Module	19
Table 4 DIP Switch Configuration	22
Table 5 MMD-TA-11B Terminal Connection Locations	23
Table 6 MMD-TA-12B Terminal Connection Locations	24
Table 7 DIN Muting Module Status Indication Breakdown	37
Table 8 Diagnostic Display Breakdown	45
Table 9 Accessories for DIN Muting Module	47
Table 10 Documentation	47

Intentionally Left Blank

1 SAFETY

This Chapter details all the necessary safety information relating to the DIN Muting Module and its intended use.

1.1 SAFETY NOTICES

1.1.1 Types

In order to install and operate the product in a safe and efficient way, safety notices are displayed on the product and throughout this Instruction Manual.

The Safety Notices are categorised as follows:

1.1.1.1 Warnings

WARNING!

This type of notice is posted:

- Where potential hazards or unsafe practices exist which COULD result in severe personal injury or death if the warning is ignored
- Where there is a risk of serious injury or death if instructions are not followed; e.g. warning to disconnect power before accessing the inside of an electrical cabinet



- The **WARNING!** is on a YELLOW background

1.1.1.2 Cautions

CAUTION!

This type of notice is posted:

- Where hazards or unsafe practices exist which could result in minor or moderate injury if the caution is ignored

The CAUTION is on a YELLOW background

The text in the notice contains the following information:

- The NATURE of the HAZARD (electrical, crushing, chemical, heat, fumes, dust, flying debris, toxic, overhead load, laser, radiation, magnetic field, biological, etc.)
- The MAGNITUDE OF HARM if the warning is ignored
- An instruction pointing out HOW TO AVOID the harm



☞ It should be noted that for operating and/or maintaining this particular apparatus detailed in this document, there are no relevant CAUTIONS necessary.

1.1.1.3 Notes



NOTE:

☞ This type of notice is posted where the information is purely advisory and is classified as a Note.

1.2 PRODUCT SAFETY LABELLING INFORMATION

Table 1 on Page 1 lists the safety labels used on the product together with their descriptions and locations.



Table 1 Label Identification DIN Muting Module

SYMBOL	LOCATION/MEANING
<p>Yellow background</p> <p>WARNING!</p> 	<p>Located on DIN Muting Module left side panel.</p>  <p>Indicates the following important information:</p> <p>WARNING!</p> <p>CORRECT USE OF THIS CONTROL DEVICE IS AN ESSENTIAL PART OF PROPER MACHINE CONTROL. SEE THE INSTRUCTION MANUAL PACKED WITH THIS DEVICE FOR ALL INSTALLATION DETAILS, WIRING DIAGRAM, OPERATING INSTRUCTIONS PERIODIC CHECKOUT PROCEDURES AND WARNINGS. FAILURE TO FOLLOW ALL INSTRUCTIONS OR WARNINGS COULD LEAD TO SERIOUS BODILY INJURY OR DEATH.</p> <p>THIS DEVICE IS NOT FIELD REPAIRABLE. ALL REPAIRS MUST BE PERFORMED BY:</p> <p>BANNER ENGINEERING CORP. USA</p> <p>TEL. +1 763 544 3164</p>

1.3 WARNINGS & NOTES IN THE MANUAL

Mandatory **WARNING!** notices are written and positioned prior to the information they are applicable to throughout the Manual to indicate potential danger or hazards.

There are two different types used in this Manual:

- General **WARNINGS!** indicated by the symbol  (see example [WARNING on page 3](#))
- Electrical Shock Hazard **WARNINGS!** indicated by the symbol  (see example [WARNING on page 23](#))

The User must read the relevant **WARNINGS!** appertaining to the event before proceeding further.

☞ Notes are also written and positioned prior to the information they are applicable throughout the Manual but are non-mandatory.

1.4 SAFETY STANDARDS & EN DIRECTIVES

 The list of standards below is included as a convenience for users of this Banner product. Inclusion of these standards does not imply that the product complies specifically with any standard, other than those listed in the Specifications of this manual (block 3.2.1 on page 17 refers).

ISO 12100-1 (2003) & -2 (2003)(EN 292-1 & -2)

Safety of Machinery – Basic Concepts, General Principles for Design

ISO 13850 (2006) (EN418)

Emergency Stop Devices, Functional Aspects – Principles for Design

ISO 13852 (1996)(EN 294)

Safety Distances - Upper Limbs

ISO/DIS 13851 (2002)(EN 574)

Two-Hand Control Devices – Functional Aspects – Principles for Design

ISO 13853 (1998) (prEN 811)

Safety Distances - Lower Limbs

ISO 13849-1 (2006)(EN 954-1)

Safety-Related Parts of Control Systems

ISO/DIS 13855 (2002)(EN 999)

The Positioning of Protective Equipment in Respect to Approach Speeds of Parts of the Human Body

ISO 14119 (1998) (EN 1088)

Interlocking Devices Associated with Guards – Principles for Design and Selection

ISO 14121 (1999)(EN 1050)

Principles of Risk Assessment

IEC/EN 60204-1 (2005-10)

Electrical Equipment of Machines Part 1: General Requirements

IEC/EN 61496-1 (2004-02), & IEC/EN 61496-2 (2006-04)

Electro-sensitive Protection Equipment

IEC 60529 (2001-02)

Degrees of Protection Provided by Enclosures

IEC/EN 60947-5-1 (2003-11)

Low Voltage Switch Gear – Electromechanical Control Circuit Devices

IEC/EN 60947-1 (2004-03)

Low Voltage Switch Gear – General Rules

IEC 61508-1 (1998-12)

Functional Safety

IEC 62061 (2005-01)

Machinery Functional Safety

1.5 INGRESS PROTECTION RATINGS

The DIN Muting Module meets the following Ingress protection class as per IEC 60529:

- IEC IP20*

*The DIN Muting Module must be installed inside an enclosure rated IEC IP54 or better for IP20 rating.

1.6 ELECTRICAL SAFETY



WARNINGS!

HIGH VOLTAGE SHOCK HAZARD FOR MODEL MMD-TA-11B ONLY
ALWAYS DISCONNECT ALL POWER FROM THE MUTING MODULE AND THE GUARDED MACHINE BEFORE MAKING ANY CONNECTIONS OR REPLACING ANY COMPONENT. USE EXTREME CAUTION TO AVOID ELECTRICAL SHOCK AT ALL TIMES. SERIOUS BODILY INJURY OR DEATH COULD RESULT.

PROPER ELECTRICAL CONNECTION

ELECTRICAL CONNECTION MUST BE MADE BY QUALIFIED PERSONNEL AND MUST COMPLY WITH LOCAL ELECTRICAL STANDARDS. DO NOT MAKE CONNECTIONS TO THE SYSTEM OTHER THAN THOSE DESCRIBED IN Chapter 4 on Page 21 OF THIS MANUAL. DOING SO COULD RESULT IN SERIOUS INJURY OR DEATH.

The DIN Muting Module has been designed to meet with the Electrical Safety Standards as detailed in block 3.1.3 on page 16.

1.7 CONDITIONS OF EQUIPMENT USE

WARNINGS

READ THIS SECTION CAREFULLY BEFORE INSTALLING THE SYSTEM

THE **BANNER MMD-TA-11B** OR **-12B DIN MUTING MODULE** IS AN ACCESSORY DEVICE THAT IS TYPICALLY USED IN CONJUNCTION WITH A MACHINE SAFEGUARDING DEVICE(S). ITS ABILITY TO PERFORM THIS FUNCTION DEPENDS UPON THE APPROPRIATENESS OF THE APPLICATION AND UPON THE **DIN MUTING MODULE'S** PROPER MECHANICAL AND ELECTRICAL INSTALLATION AND INTERFACING TO THE MACHINE TO BE SAFEGUARDED.

IF ALL MOUNTING, INSTALLATION, INTERFACING, AND CHECKOUT PROCEDURES ARE NOT FOLLOWED PROPERLY, THE **DIN MUTING MODULE** CANNOT PROVIDE THE PROTECTION FOR WHICH IT WAS DESIGNED. THE USER HAS THE RESPONSIBILITY TO ENSURE THAT ALL LOCAL, STATE, AND NATIONAL LAWS, RULES, CODES, OR REGULATIONS RELATING TO THE INSTALLATION AND USE OF THIS CONTROL SYSTEM IN ANY PARTICULAR APPLICATION ARE SATISFIED. EXTREME CARE SHOULD BE TAKEN TO ENSURE THAT ALL LEGAL REQUIREMENTS HAVE BEEN MET AND THAT ALL TECHNICAL INSTALLATION AND MAINTENANCE INSTRUCTIONS CONTAINED IN THIS MANUAL ARE FOLLOWED. READ ALL OF THE [Safety Information in Chapter 1](#) OF THIS MANUAL CAREFULLY BEFORE INSTALLING THE SYSTEM. FAILURE TO FOLLOW THESE INSTRUCTIONS COULD RESULT IN SERIOUS BODILY INJURY OR DEATH. THE USER HAS THE SOLE RESPONSIBILITY TO ENSURE THAT THE **BANNER DIN MUTING MODULE** IS INSTALLED AND INTERFACED TO THE SAFEGUARDED MACHINE BY A [Qualified Person as specified in block 1.9.2 on Page 3](#) IN ACCORDANCE WITH THIS MANUAL AND APPLICABLE SAFETY REGULATIONS.

STAND ALONE POINT OF OPERATION GUARDING

THE **DIN MUTING MODULE** IS NOT A STAND ALONE POINT OF OPERATION SAFEGUARDING DEVICE(S), AS DEFINED BY EUROPEAN SAFETY STANDARDS. IT IS THEREFORE NECESSARY TO INSTALL POINT OF OPERATION SAFEGUARDING DEVICE(S), SUCH AS SAFETY LIGHT SCREENS AND/OR FIXED GUARDS, TO PROTECT PERSONNEL FROM HAZARDOUS MACHINERY. FAILURE TO PROPERLY INSTALL POINT OF OPERATION SAFEGUARDING ON HAZARDOUS MACHINERY, AS INSTRUCTED BY THE APPROPRIATE INSTALLATION MANUALS, CAN RESULT IN A DANGEROUS CONDITION WHICH COULD LEAD TO SERIOUS INJURY OR DEATH.

USER RESPONSIBILITY FOR APPLICATION SAFETY

THE MUTING APPLICATION EXAMPLES DESCRIBED IN [appendix A3 on page 61](#) DEPICT GENERALIZED SAFEGUARDING SITUATIONS. EVERY SAFEGUARDING APPLICATION HAS A UNIQUE SET OF REQUIREMENTS. EXTREME CARE IS URGED TO ENSURE THAT ALL LEGAL REQUIREMENTS ARE MET AND THAT ALL INSTALLATION INSTRUCTIONS ARE FOLLOWED. IN ADDITION, ANY QUESTIONS REGARDING SAFEGUARDS SHOULD BE DIRECTED TO THE [Corporate Office as listed on page 69](#).

1.7.1 Appropriate Applications

The correct application of the MMD-TA-11B and -12B DIN Muting Modules are dependent on the type of machine and the safeguards that are to be interfaced with the Module. The Module is generally interfaced with safeguards that may be used only on machinery that is capable of stopping motion immediately upon receiving a stop signal and at any point in its machine cycle. It is the user's responsibility to verify whether the safeguards are appropriate for the application and are installed as instructed by the appropriate installation manuals.

1.7.2 Non-Appropriate Applications

Safety Light Screens, Single/Multiple Beam Safety Systems, or other Presence-Sensing Safeguarding Device(s) (PSSDs) generally may **NOT** be used for the following:

- With single stroke (also called "full revolution") clutched machinery, as this type of machinery is incapable of stopping immediately
- On certain other types of machinery, including any machine with inadequate or inconsistent stopping response time, or any machine that ejects materials or component parts through the defined area
- In any environment likely to adversely affect the efficiency of the safeguard(s) or the DIN Muting Module. For example, corrosive chemicals or fluids or unusually severe levels of smoke or dust, if not controlled, may degrade the efficiency of a safety light screen

If there is any doubt about whether or not your machinery is compatible with this DIN Muting Module, contact *Banner's* Application Engineers at the factory.

1.8 SECURITY PROTOCOL

The DIN Muting Module must be mounted inside a lockable enclosure or cabinet rated IP54 or better, both to protect the Module from environmental conditions and in order to prevent access by unauthorized personnel, if required by applicable standards.

The key (or combination) to the enclosure should be kept in the possession of a [Qualified Person as specified in block 1.9.2 on Page 3](#) and only they should have access to the configuration switches.

1.9 DESIGNATED & QUALIFIED PERSONS

1.9.1 Designated Person

A **Designated Person** ([designated person on page 65](#)) is identified and designated in writing, by the employer, as being appropriately trained and able to perform the specified checkout procedures on the DIN Muting Module.

1.9.2 Qualified Person

A **Qualified Person** ([qualified person on page 66](#)) by possession of a recognised degree or certificate of professional training, or by extensive knowledge, training and experience, has successfully demonstrated the ability to solve problems relating to the implementation of this safety system.

1.10 CONTROL RELIABILITY

1.10.1 Redundancy & Self-Checking

The DIN Muting Module microprocessor-based circuitry features a diverse-redundant design. In addition, the DIN Muting Module is extensively FMEA (Failure Mode and Effects Analysis) (see [FMEA on page 66](#)) tested to establish an extremely high probability that no system component will ever (even if it does fail) cause a failure to danger. This design philosophy aids machine designers to comply with U.S. control reliability and worldwide standards for the highest level of safety.

Redundancy requires that DIN Muting Module circuit components be “backed up” to the extent that, if the failure of a single component will prevent effective machine stopping action when needed, that component must have a redundant counterpart which will perform the same function. The microprocessor-controlled Muting Module is designed with diverse redundancy. Diverse-redundant components are of different designs, and microprocessor programs used by them run from different instruction sets.

Redundancy must be maintained for as long as the DIN Muting Module is in operation. Since a redundant system is no longer redundant once a component has failed, the Module is designed to be continuously self-checking. A component failure detected by or within the self-checking system causes a stop signal to be sent to the safeguarded machine and puts the Module into a lockout condition.

Recovery from this type of lockout condition requires replacement of the failed component (to restore redundancy) and the appropriate reset procedure (see [block 4.5.1.1 on page 25](#)). Possible causes are listed in [block 6.2.1 on page 45](#). The Diagnostic Display is used to diagnose causes of a lockout condition (see [block 6.2.1.1 on page 45](#) and [table 8 on page 45](#)).

1.11 DIN MUTING MODULE(S) SAFETY FEATURES

1.11.1 Automatic or Monitored Manual Reset Select

The selectable Automatic or Monitored Manual Reset (X1-X2) provides flexibility for the User who has applications in which the operator is continually sensed, or in applications where the operator can pass through and become clear of the sensing field. See [block 1.11.15 on page 8](#) *Pass-Through Hazards* or other applications requiring a manual reset.

The configuration is selected via two banks of DIP switches located under the DIN Muting Module's front cover (see [figure 7 on page 22](#)).

1.11.1.1 Monitored Manual Reset

Monitored Manual Reset is typically used in situations where the individual can pass through a sensing field and become clear of a Safeguarding Device(s), such that the device can no longer prevent hazardous motion; for example, perimeter guarding. The DIN Muting Module monitors the input for two transitions: from open-to-closed, and from closed-to-open within a certain time period. This prevents the reset button from being tied down or failing in a closed condition, and causing an unintended or automatic reset.

Upon power-up, when the Module has been configured for manual reset, for the OSSD (Output Switching Signal Device) outputs to turn ON, both the MSSI (Muteable Safety Stop Interfaces) and the SSI (Safety Stop Interfaces) must be active (closed) and a monitored manual reset must be accomplished. The reset is accomplished by closing the Reset input for a minimum of 1/4 second, but not longer than 2 seconds and then re-opening the input. The OSSD outputs turn ON once the open-closed-open action occurs.

In this configuration, the DIN Muting Module must be manually reset after power-up, lockouts, and after the cycling of either the MSSI (not muted) or the SSI. The location for the manual reset device (for example: a N.O. key switch) must comply with the [WARNING on page 38](#) and refer to that block for further information on key resets.

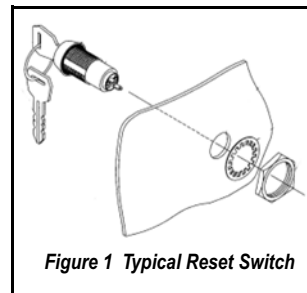

Figure 1 Typical Reset Switch

1.11.1.2 Automatic Reset

Upon power-up, when the DIN Muting Module is configured for automatic reset, the OSSD outputs automatically turn ON once power is applied, the self-test is accomplished, and the MSSI and the SSI are active (closed). The OSSD outputs also turn ON after either interface is de-activated and then re-activated. In either case, no external input or reset is required.

Automatic reset is typically used in situations where the individual is continually sensed by the defined area or in situations where supplementary guarding prevents the initiation of hazardous motion while an individual is within the safeguarded area (for example: point-of-operation guarding).

In either case, a Manual Reset must be performed to recover from a lockout condition.

In Automatic Reset mode, input X1-X2 stays open.

1.11.2 Lockout Conditions

A lockout condition of the DIN Muting Module causes both OSSD outputs to go OFF. A lockout condition is indicated by a flashing Red status indicator and an error number displayed on the Diagnostic Display.

A description of possible lockouts, their causes, troubleshooting hints, and a Manual Reset routine are listed in [block 6.2.1 on page 45](#).

1.11.3 Mutable Safety Stop Interface & Safety Safety (Protective) Stop Interface

WARNING

EMERGENCY STOP FUNCTIONS

DO NOT CONNECT ANY EMERGENCY STOP DEVICES TO THE MSSI INPUT; DO NOT MUTE OR BYPASS ANY EMERGENCY STOP DEVICE. IEC/EN 60204-1 REQUIRES THAT THE EMERGENCY STOP FUNCTION REMAINS ACTIVE AT ALL TIMES. MUTING OR BYPASSING THE SAFETY OUTPUTS RENDERS THE EMERGENCY STOP FUNCTION INEFFECTIVE.

1.11.3.1 Mutable Safety Stop Interface (MSSI)

The Mutable Safety Stop Interface (MSSI) input (S11-S12, S21-S22) is a specialised SSI that can be muted during the non-hazardous portion of the machine cycle.

The Module requires redundant input signals from the external primary guarding which is to be muted. These inputs typically are either two *Banner* solid-state safety outputs or two monitored forced-guided relay outputs from an appropriate safety device. See [table 2 on page 17](#), and [block 4.5.5 on page 26](#) for complete information.

1.11.3.2 Safety (Protective) Stop Interface (SSI)

The DIN Muting Module has a provision for an additional Safety (Protective) Stop Interface (X5-X6, X7-X8) to connect an optional device, such as a supplemental safeguard, E-stop button, or safety switch(es), to issue a stop command. This dual-channel interface is similar to the MSSI, but is always functional, even when the primary safety device is being muted. See [table 2 on page 17](#), and [block 4.5.5 on page 26](#) for complete information.

Safety Interlocking Switch Requirements

The following general requirements and considerations apply to the installation of interlocked guards and gates for the purpose of safeguarding. In addition, refer to the relevant regulations to be sure to comply with all necessary requirements.

Hazards guarded by the interlocked guard must be prevented from operating until the guard is closed; a stop command must be issued to the guarded machine if the guard opens while the hazard is present. Closing the guard must not, by itself, initiate hazardous motion; a separate procedure must be required to initiate the motion. The safety switches must not be used as a mechanical or end-of-travel stop.

The guard must be located an adequate distance from the danger zone (so that the hazard has time to stop before the guard is opened sufficiently to provide access to the hazard), and it must open either laterally or away from the hazard, not into the safeguarded area. The guard also should not be able to close by itself and activate the interlocking circuitry. In addition, the installation must prevent personnel from reaching over, under, around or through the guard to the hazard. Any openings in the guard must not allow access to the hazard (see EN 294, ISO 14120/EN953 or the appropriate standard). The guard must be strong enough and designed to protect personnel and contain hazards within the guarded area, which may be ejected, dropped or emitted by the machine.

The safety interlocking switches and actuators used with the Muting Module must be designed and installed so that they cannot be easily defeated. They must be mounted securely, so that their physical position can not shift, using reliable fasteners that require a tool to remove them.

Positive-Opening Safety Interlocking Switches

Safety interlock switches used with the Muting Module must satisfy several requirements. Each switch must provide electrically isolated contacts: at minimum, one normally closed (N.C.) contact from each individually mounted switch.

The contacts must be of “positive-opening” (direct-opening) design, as described by IEC 60947-5-1, with one or more normally closed contacts rated for safety. Positive-opening operation causes the switch to be forced open, without the use of springs, when the switch actuator is disengaged or moved from its home position (see the *Banner Safety Catalogue* for examples). In addition, the switches must be mounted in a “positive mode,” to move/disengage the actuator from its home position and open the normally closed contact, when the guard opens.

1.11.4 Output Signal Switching Device (OSSD) Outputs

The DIN Muting Module MMD-TA-12B has two solid-state safety outputs (Y5-Y6, Y7-Y8) and DIN Muting Module MMD-TA-11B has two normally open hard-contact safety outputs (13-14, 23-24), labelled “OSSD1” and “OSSD2” (see [figure 11 on page 49](#)). The solid-state safety outputs are actively monitored to detect short circuits to the supply voltage, to each other, and to other sources of electrical energy. If a failure is detected, the outputs switch to an OFF-state. For circuits requiring the highest level of safety and reliability, either OSSD must be capable of stopping the motion of the safeguarded machine in an emergency.

During the muted portion of the machine cycle, the MSSI inputs are ignored but OSSD 1 and OSSD 2 remain ON. During other portions (not muted) of the cycle, if the MSSI either opens or goes OFF, OSSD 1 and OSSD 2 go OFF.

In any case, if the SSI interface opens, OSSD1 and OSSD2 go OFF. See [appendix A2 on page 59](#) for timing diagrams.

1.11.5 Auxiliary (Aux) Output

The Auxiliary (Aux) monitoring PNP (Z3-Z4) output on the MMD-TA-12B and the parallel N.C. contact output on the -11B are intended for non-safety related purposes. The status of this auxiliary output is indicated by the green Status LED. See [block 1.11.9 on page 7](#) for more information.

1.11.6 External Device Monitoring (EDM)

Two inputs are provided (see [figure 12](#), [figure 13](#), [figure 14](#), [figure 15](#) & [figure 16](#)) for monitoring the state of external devices, such as MPCEs. These terminals are labelled EDM 1 (Y1-Y2) and EDM 2 (Y3-Y4). The Module's EDM inputs can be configured in three ways: One Channel, Two Channel, or No Monitoring (see [figure 7](#) on [page 22](#) for DIP switch settings and [block 4.7.2](#) on [page 33](#) for external connection). One Channel and Two Channel EDM is used when the OSSD outputs directly control the de-energizing of the MPCEs or external devices.

1.11.6.1 One Channel Monitoring

A series connection of closed monitor contacts that are forced-guided (mechanically linked) from each device controlled by the DIN Muting Module. The monitor contacts must be closed before the Module can be reset (either Manual or Automatic). After a reset is executed and the safety outputs (OSSDs) are closed, the status of the monitor contacts is no longer monitored. However, the monitor contacts must be closed within 200 milliseconds of the OSSD outputs going from ON to OFF.

1.11.6.2 Two Channel Monitoring

An independent connection of closed monitor contacts that are forced-guided (mechanically linked) from each device controlled by the DIN Muting Module. Both EDM inputs must be closed before the Module can be reset and the OSSDs can turn ON. While the OSSDs are ON, the inputs may change state (either both open, or both closed). If the inputs remain in opposite states for more than 200 ms, a lockout occurs. Additionally, both inputs must be closed 200 ms after the OSSD outputs go OFF or a lockout occurs.

1.11.6.3 No Monitoring

If no monitoring is desired, the 1-ch/2-ch selection switches must be configured for two-channel EDM, and Y1 must be jumpered to Y3. If the Module is set for No Monitoring, the user must ensure that any single failure of the external devices does not result in a hazardous condition and a successive machine cycle is prevented (see [block 1.10](#) on [page 4](#) Control Reliability).

1.11.7 Mute Devices & Mute Inputs (M1-M4)

1.11.7.1 The Muting Function

To mute the primary Safeguarding Device(s) appropriately, the design of a muting system must:

- Identify the non-hazardous portion of the machine cycle
- Involve the selection of the proper muting devices, and
- Include proper mounting and installation of those devices

The Module can monitor and respond to redundant signals that initiate the mute (M1: Z11-Z21; M2: Z12-Z22; M3: Z13-Z23; M4: Z14-Z24). The mute then suspends the safeguarding function by ignoring the state of the MSSl. This allows a person to interrupt the defined area to load and/or unload parts or an object to pass through the defined area of a safety light screen, without generating a stop command. (this should not be confused with blanking, which disables one or more beams in a safety light screen, resulting in larger minimum object sensitivity). See [appendix A2](#) on [page 59](#) for example: mute timing sequences.

The mute may be triggered by a variety of external devices. This feature provides a variety of options (see [block 1.11.7](#) on [page 6](#) and [block 1.11.9](#) on [page 7](#)) to tailor the System to the requirements of a specific application.

A pair of muting devices must meet be triggered simultaneously within 3 seconds of one another (see [block 1.11.8.1](#) on [page 7](#)). This reduces the chance of common mode failures or defeat.

1.11.7.2 Mute Devices



WARNINGS

MUTING LIMITATIONS

MUTING IS ALLOWED ONLY DURING THE NON-HAZARDOUS PORTION OF THE MACHINE CYCLE. A MUTING APPLICATION MUST BE DESIGNED SO THAT NO SINGLE COMPONENT FAILURE CAN PREVENT THE STOP COMMAND OR ALLOW SUBSEQUENT MACHINE CYCLES UNTIL THE FAILURE IS CORRECTED AS PER ISO/DIS 13855.

MUTE INPUTS MUST BE REDUNDANT

IT IS NOT ACCEPTABLE TO USE A SINGLE SWITCH, DEVICE, OR RELAY WITH TWO N.O. CONTACTS FOR THE MUTE INPUTS. THIS SINGLE DEVICE, WITH MULTIPLE OUTPUTS, MAY FAIL SO THAT THE SYSTEM IS MUTED AT AN INAPPROPRIATE TIME. THIS MAY RESULT IN A HAZARDOUS SITUATION.

The beginning and end of a mute cycle must be triggered by outputs from either pair of muting devices, depending on the application. The mute device pairs both must have normally open contacts, or have one device with a PNP output and one device with a NPN output, both of which fulfil the [General Muting Device Requirements](#) on [page 7](#). These contacts must close (conducting) when the switch is operated to initiate the mute, and must open (non-conducting) when the switch is not operated and in a power-OFF condition.

The Module monitors the mute devices to verify that their outputs turn ON within 3 s of each other. If the inputs do not meet this see simultaneity requirement ([Simultaneity Requirement](#), see [page 67](#)), a mute condition can not occur.

Several types and combinations of mute devices can be used, including, but not limited to: limit switches, photoelectric sensors, positive-drive safety switches, inductive proximity sensors, and whisker switches.

General Muting Device Requirements

The muting devices (typically sensors or switches) must, at a minimum, comply with the following requirements:

- There must be a minimum of two independent hard-wired muting devices
- The muting devices must either both have normally open contacts; or one device with a PNP output and one device with a NPN output, both of which must fulfil the input requirements listed in [table 2 on page 17](#). These contacts must close when the switch is operated, and must open (or not conduct) when the switch is not operated or in a power OFF condition
- The activation of the inputs to the muting function must be from separate sources. These sources must be mounted separately in order to prevent an unsafe muting condition resulting from maladjustment, misalignment, or a single common mode failure. (For example: physical damage to the mounting surface could cause both muting devices to be knocked out of alignment, resulting in false muting input signals.) Only one of these sources may pass through, or be affected by, a programmable logic controller (PLC) or similar device
- The muting devices must be installed so that they can not be easily defeated or bypassed
- The muting devices must be mounted so that their physical position and alignment can not be easily changed
- It must not be possible for environmental conditions to initiate a mute condition (for example: extreme airborne contamination)

The muting devices must not be set to use any delay or other timing functions (unless such functions are accomplished so that no single component failure prevents the removal of the hazard, subsequent machine cycles are prevented until the failure is corrected, and no hazard is created by extending the muted period).

1.11.8 Mute Enable (ME)

The Mute Enable (ME) input is a non-safety-rated input. When the input is closed (terminals X13-X14 jumpered), the Module allows a mute condition to occur; opening this input while the System is muted has no effect. The Module is factory-supplied with a jumper installed between terminals X13-X14. To disable the mute function, the jumper should be removed.

Typical uses for ME include:

- To allow the machine control logic to create a *window* for muting to begin
- To inhibit muting from occurring or
- To reduce the chance of unauthorized or unintended bypassing or defeat of the safety system

1.11.8.1 Simultaneity Timer Reset Function

The ME input can also be used to reset the Simultaneity Timer of the mute inputs. If one input is active for longer than 3 s before the second input becomes active, the Simultaneity Timer prevents a mute cycle from occurring. This could be due to a normal stoppage of an assembly line that may result in blocking one mute device and the simultaneity time running out.

If the ME input is cycled (closed-open-closed) while one mute input is active, the Simultaneity Timer is reset, and if the second mute input becomes active within 3 s, a normal mute cycle begins. The timing requirement for the closed-open-closed is similar to the manual reset

function. Initially, the input needs to be active (closed) for longer than 0,25 s, then open for longer than 0,25 s, but not longer than 2 s, and then must reclose to reset the Simultaneity Timer. The function can reset the timer only once per mute cycle (that is, all mute inputs M1-M4 must open before another reset can occur).

1.11.9 Mute Lamp Output (ML)

WARNING!

MUTE STATUS MUST BE READILY OBSERVABLE

INDICATION THAT THE SAFETY DEVICE IS MUTED MUST BE PROVIDED AND MUST BE READILY OBSERVABLE AS PER ISO/DIS 13855 (2002). FAILURE OF THIS INDICATION SHOULD BE DETECTABLE AND PREVENT THE NEXT MUTE, OR, THE OPERATION OF THE INDICATOR SHOULD BE VERIFIED AT SUITABLE INTERVALS.

Some applications require that a lamp (or other means) be used to indicate when the primary Safeguarding Device(s) (for example: light screen) is muted. The DIN Muting Module provides for this (X3-X4 see [WARNING on page 7](#)). This indication is selectable between a monitored or a non-monitored output signal (NPN sinking). The monitored output prevents the initiation of a mute after an indicator failure is detected (current draw falls below 10 mA or goes above 360 mA).

1.11.10 Mute On Power-Up

WARNING!

MUTE ON POWER-UP

THE MUTE ON POWER-UP FUNCTION SHOULD ONLY BE USED IN APPLICATIONS WHERE MUTING THE SYSTEM (M1 AND M2 CLOSED) WHEN POWER IS APPLIED IS REQUIRED, AND USING IT, MUST NOT IN ANY SITUATION, EXPOSE PERSONNEL TO ANY HAZARD.

Mute Enable must be closed to allow Mute on Power-Up. (see [WARNING on page 7](#)) If selected, the Mute on Power-Up function initiates a mute when power is applied, the Mute Enable input is closed, the MSS1 inputs are active (closed), and either M1-M2 or M3-M4 (but not all four) are closed.

If Auto Reset is configured, the Module allows 10 s for the MSS1 and SSI to become active (closed), to accommodate systems that may not be immediately active at power-up.

If Manual Reset is configured, the first valid reset after the MSS1 and SSI are active (closed) results in a mute cycle if all other conditions are satisfied.

1.11.11 Override

WARNING!

LIMITING USE OF OVERRIDE FUNCTION

THE OVERRIDE FUNCTION IS NOT FOR MACHINE SETUP OR PRODUCTION. IT IS TO BE USED ONLY TO CLEAR THE PRIMARY SAFEGUARDING DEVICE(S), SUCH AS IF MATERIAL BECOMES STUCK IN THE DEFINED AREA OF A SAFETY LIGHT SCREEN. WHEN OVERRIDE IS USED, IT IS THE USER'S RESPONSIBILITY TO INSTALL AND USE IT ACCORDING TO CURRENT SAFETY STANDARDS (SEE [block 1.4 on page 2](#)). IN ADDITION, THE REQUIREMENTS LISTED IN STANDARD IEC/EN60204-1 BLOCK 9.2.4 MUST BE SATISFIED.

The Override function (X9-X10, X11-X12) allows the User to manually force the OSSD outputs ON for up to 30 s in a situation such as an object becoming stuck in the defined area of a safety light screen after the mute ends (for example: a car body on a transfer line entering a work cell). The feature is intended to allow the User to dislodge the part out of the defined area. The need to perform an Override is indicated by a flashing mute lamp.

This input requires two normally open switches, both of which must be closed within 3 s of each other. The Override cycle lasts a maximum of 30 s, after which the Override input must be released for at least 0,5 s prior to the next Override cycle. An Override can be initiated only after tripping of the MSS1 inputs causes the Module to latch its OSSDs OFF.

 A stop command issued by the SSI cannot be overridden.

When Override is used, the following precautions must be taken:

- Prevent exposure to any hazard during an Override cycle
- Provide a readily observable indication of an Override
- Provide supplementary guarding, per IEC/EN60204-1 Block 9.2.4

The Override switches must be supervised and must prevent automatic operation. Also, one or more of the following must be true:

- Motion is initiated by a hold-to-run or similar device
- If a portable control station (for example: an enabling device) with an emergency stop device is used, motion may be initiated only from that station
- Motion, speed, or power of the machine is limited
- The machine's range of motion is limited

1.11.12 One Way/Two Way Muting

One-way (directional) muting allows the Safeguarding Device(s) to be muted only if mute devices are operated in the order M1, M2 (mute initiated), M3 and M4. This method allows for a single-direction material flow and reduces the possibility of intentional defeat of the muting devices.

Two-way (non-directional) muting allows the Safeguarding Device(s) to be muted any time the actuation of M1-M2 or M3-M4 meets the 3 second [Simultaneity Requirement](#), see [page 67](#). This allows the flow of material from either direction (two-way material flow).

 When using four mute devices (M1, M2, M3 and M4), in order to extend the mute until the light screen is clear, the object must activate all four of the devices at one time during the mute cycle.

1.11.13 Use of Corner Mirrors with Optical Safety Systems

WARNING!

GUARDING MULTIPLE AREAS

DO NOT GUARD MULTIPLE AREAS, WITH MIRRORS OR MULTIPLE SENSING FIELDS, IF PERSONNEL CAN ENTER THE HAZARDOUS AREA WHILE THE SYSTEM IS MUTED, AND NOT BE DETECTED BY SUPPLEMENTARY GUARDING THAT ISSUES A STOP COMMAND TO THE MACHINE (SEE [block 1.11.15 on page 8](#), PASS THROUGH HAZARDS).

Mirrors are typically used with safety light screens and single-/multiple-beam safety systems to safeguard multiple sides of a hazardous area. If the safety light screen is muted, the safeguarding function is suspended on all sides. It must not be possible for an individual to enter the safeguarded area without being detected and a stop command issued to the machine control. This supplementary guarding is normally provided by an additional device(s) that remains active while the Primary guarding is muted and could be interfaced with the SSI input. Therefore, **mirrors are typically not allowed for muting applications.**

1.11.14 PSSDs

Muting multiple PSSDs (see [page 65](#)) or a PSSD with multiple sensing fields is not recommended unless it is not possible for an individual to enter the safeguarded area without being detected and a stop command issued to the machine control. As with the use of corner mirrors (see above), if multiple sensing fields are muted, the possibility exists that personnel could move through a muted area or access point to enter the safeguarded area without being detected.

For example: in an entry/exit application where a pallet initiates the mute cycle by entering a cell, if both the entry and the exit PSSDs are muted, it may be possible for an individual to access the safeguarded area through the exit of the cell. An appropriate solution would be to mute the entry and the exit with separate Safeguarding Device(s).

1.11.15 Pass-Through Hazards

WARNING!

PASS-THROUGH HAZARDS, PSSD & MUTING

IF THE PSSD (see [page 65](#)) IS SAFEGUARDING AN APPLICATION IN WHICH PERSONNEL HAVE ACCESS INTO THE SENSING AREA OR FIELD (FOR EXAMPLE: A MACHINE OPERATOR AT THE POINT OF OPERATION) WHILE THE PSSD IS MUTED, ALL PASS-THROUGH HAZARDS MUST BE ELIMINATED. THE INDIVIDUAL MUST BE SENSED CONTINUALLY WHILE IN THE SAFEGUARDED AREA. THIS PREVENTS INITIATION OF A MACHINE CYCLE IF THE MUTE ENDS WHILE THE INDIVIDUAL IS WITHIN THE HAZARDOUS AREA. SEE [appendix A3 on page 61](#) FOR EXAMPLES. IF THE PASS-THROUGH HAZARD CANNOT BE ELIMINATED, AS IN ENTRY/EXIT APPLICATIONS, THE INDIVIDUAL MUST BE DETECTED ENTERING THE SAFEGUARDED AREA AND THE HAZARDOUS MOTION MUST STOP IMMEDIATELY.

A pass-through hazard is associated with applications where personnel may pass through a safeguard (at which point the hazard stops or is removed) and then may continue into the hazardous area. Subsequently, their presence is no longer detected, and the safeguard can not prevent the start or restart of the machine. The related danger is the unexpected start or restart of the machine while personnel are within the hazardous area.

In the use of safety light screens, a pass-through hazard typically results from large MINIMUM SAFETY DISTANCES calculated from long stopping times, large defined area resolutions, reach over, reach through, or other installation considerations.

A pass-through hazard can be generated with as little as 75 mm between the defined area and the machine frame or fixed guarding.

1.11.16 FSD Interfacing Connections

FSDs can take many forms, though the most common are captive contact, forced-guided relays or Interfacing Modules. The mechanical linkage between the contacts allow the device to be monitored by the external device monitoring circuit for certain failures.

Dependent on the application, the use of FSDs can facilitate controlling voltage and current that differs from the OSSD outputs of the Module. FSDs can also be used to control an additional number of hazards by creating multiple safety stop circuits.

1.11.16.1 Safety (Protective) Stop Circuits

A safety stop allows for an orderly cessation of motion or hazardous situation for safeguarding purposes, which results in a stop of motion and removal of power from the MPCEs (assuming this does not create additional hazards). A safety stop circuit typically comprises a minimum of two normally open contacts from forced-guided (mechanically linked) relays, which are monitored to detect certain failures such that the loss of the safety function does not occur (that is External Device Monitoring). Such a circuit can be described as a safe switching point.

Typically, safety stop circuits are either single channel (a series connection of at least two N.O. contacts); or dual channel (a parallel connection of two N.O. contacts). In either method, the safety function relies on the use of redundant contacts to control a single hazard, so that if one contact fails ON, the second contact arrests the hazard and prevents the next cycle from occurring.

Interfacing safety stop circuits must be wired so that the safety function can not be suspended, overridden, or defeated, unless accomplished in a manner at the same or greater degree of safety as the machine's safety-related control system that includes the Module.

The normally open outputs from an IM-T-9A or -11A interfacing module are a series connection of redundant contacts that form safety stop circuits and can be used in either single-channel or dual-channel control methods (see figure 13 on page 51 and figure 14 on page 52).

1.11.16.2 Dual-Channel Control

Dual-Channel (or two-channel) control has the ability to electrically extend the safe switching point beyond the FSD contacts. With proper monitoring (that is, EDM), this method of interfacing is capable of detecting certain failures in the control wiring between the safety stop circuit and the MPCEs. These failures include a short-circuit of one channel to a secondary source of energy or voltage, or the loss of the switching action of one of the FSD outputs. The result could lead to the loss of redundancy or a complete loss of safety if not detected and corrected.

The possibility of a failure to the wiring increases as the physical distance between the FSD safety stop circuits and the MPCEs increase, as the length or the routing of the interconnecting wires increases, or if the FSD safety stop circuits and the MPCEs are located in different enclosures. Thus, dual-channel control with EDM monitoring should be used in any installation where the FSDs are located remotely from the MPCEs.

1.11.16.3 Single-Channel Control

Single-channel (or one-channel) control, as mentioned, uses a series connection of FSD contacts to form a safe switching point. After this point in the machine's safety-related control system, failures can occur that would result in the loss of the safety function (e.g., a short-circuit to a secondary source of energy or voltage).

Thus, this method of interfacing should only be used in installations where FSD safety stop circuits and the MPCEs are physically located within the same control panel, adjacent to each other, and are directly connected to each other; or where the possibility of such a failure can be excluded. If this can not be achieved, then two-channel control should be used.

Methods to exclude the possibility of these failures include, but are not limited to:

- Physically separating interconnecting control wires from each other and from secondary sources of power
- Routing interconnecting control wires in separate conduit, runs, or channel
- Routing interconnecting control wires with low voltage or neutral that can not result in energizing the hazard
- Locating all elements (modules, switches, devices under control, etc.) within the same control panel, adjacent to each other and directly connected with short wires
- Properly installing multi-conductor cabling and multiple wires that pass through strain-relief fittings. Over-tightening of a strain-relief can cause short-circuits at that point
- Using positive-opening or direct-drive components installed and mounted in a positive mode

1.12 DISCLAIMER INFORMATION

WARNING!

IMPORTANT... READ THIS BLOCK BEFORE PROCEEDING!

WHETHER OR NOT ANY PARTICULAR DIN MUTING MODULE INSTALLATION MEETS ALL APPLICABLE REQUIREMENTS DEPENDS UPON FACTORS THAT ARE BEYOND THE CONTROL OF *BANNER ENGINEERING CORP.* THESE FACTORS INCLUDE THE DETAILS OF HOW THE DIN MUTING MODULE IS APPLIED, INSTALLED, WIRED, OPERATED, AND MAINTAINED. IT IS THE RESPONSIBILITY OF THE PURCHASER AND USER TO APPLY THIS DIN MUTING MODULE IN FULL COMPLIANCE WITH ALL RELEVANT APPLICABLE REGULATIONS AND STANDARDS. DIN MUTING MODULE CAN ONLY SAFEGUARD AGAINST ACCIDENTS WHEN THEY ARE PROPERLY INSTALLED/INTEGRATED INTO THE MACHINE, PROPERLY OPERATED, AND PROPERLY MAINTAINED. *BANNER ENGINEERING CORP.* HAS ATTEMPTED TO PROVIDE COMPLETE APPLICATION, INSTALLATION, OPERATION, AND MAINTENANCE INSTRUCTIONS.

THE USER HAS THE RESPONSIBILITY TO ENSURE THAT ALL LOCAL, STATE, AND NATIONAL LAWS, RULES, CODES, AND REGULATIONS RELATING TO THE USE OF THIS SAFEGUARDING SYSTEM IN ANY PARTICULAR APPLICATION ARE SATISFIED.

EXTREME CARE IS URGED TO ENSURE THAT ALL LEGAL REQUIREMENTS HAVE BEEN MET AND THAT ALL INSTALLATION AND MAINTENANCE INSTRUCTIONS CONTAINED IN THIS MANUAL ARE FOLLOWED.

FOR A LIST OF EUROPEAN & INTERNATIONAL STANDARDS APPERTAINING TO THIS EQUIPMENT, REFER TO [block 1.4 on page 2](#).

1.13 EQUIPMENT NOISE LEVELS

The DIN Muting Module does not generate noise and is therefore in compliance with:

- IEC/EN 61000-6-1
- EN 55011 (CISPR11)

1.14 EQUIPMENT VIBRATION LEVELS

For shock and vibration levels, the DIN Muting Module is in compliance with:

- IEC 61496-1

1.15 EQUIPMENT RADIATION LEVELS

1.15.1 Electromagnetic Immunity Levels

For electro-magnetic levels, the DIN Muting Module is in compliance with IEC 61496-1.

2 INTRODUCTION

This Chapter details information of an introductory nature to the equipment.

2.1 PRODUCT FEATURES

- Compact, 67.5 mm DIN-mounted housing with plug-in terminal blocks
- For use with EZ-SCREEN® Output Signal Switching Device (OSSD) outputs or MINI-SCREEN®, MICRO-SCREEN®, MACHINE-GUARD™, or other safety devices with hard relay contact safety output(s) or +24V dc (PNP) outputs
- Monitors two or four inputs to automatically suspend the safety function of a safeguarding device or system
- Safety (protective) Stop Interface (SSI) for connection of supplemental safeguarding devices, E-stops, or other devices
- Selectable External Device Monitoring (EDM)
- Selectable Automatic or Monitored Manual Reset provides flexibility for point-of-operation, area, or perimeter guarding
- Two N.O. safety contacts (model MMD-TA-11B) or diverse-redundant solid-state safety outputs (model MMD-TA-12B)
- Status LEDs and two-digit Diagnostic Display indicate module status
- Easy configuration for:
 - Auto/manual reset
 - One-/two-channel EDM
 - One-/two-direction muting
 - Selectable mute enable
 - Monitored/non-monitored mute lamp
 - Selectable backdoor timer
 - Selectable mute on power-up

2.2 ABOUT THIS MANUAL

This Manual consists of a number of Chapters.

A block numbering system is also used in the Manual to assist in easy location and readability of information in a logical way.

Chapters are numbered 1, 2, 3 and so forth.

Block numbering is broken down into up to 4 levels of information as follows:

Level	1	Title in upper Case 13 pt
Level	1.1	Title in upper Case 10 pt
Level	1.1.1	Title in Title Case 10 pt
Level	1.1.1.1	Title in Title Case 8 pt



Illustrations are numbered 1, 2, 3, 4, etc. throughout the Manual.

Tables are numbered 1, 2, 3, 4, etc. throughout the Manual.

For ON LINE versions of the Manual, there is an interactive Table of Contents (Bookmarks) on the left hand side, which breaks down into 4 block levels as well as Figure and Table Listings.

If the bookmarks are not visible when the document is opened: they may be activated by clicking Window then Bookmarks from the menu. Clicking a bookmark directs the Reader to the information.

For printed versions of this document, there is a conventional Table of Contents at the beginning of this document.

For Readers of the ON LINE version of this document, Cross References are identified in blue type and are hypertexted. That is to say, when scrolling through the document using the mouse, the cursor changes from  to . At this point if the mouse is clicked, the Reader is routed directly to that particular reference. The Reader can return to the original place in the document by clicking on the **Bookmark**  then selecting **Go to Bookmark** or alternatively clicking on the highlighted bookmark.

In general emphasis is used to emphasize information of medium importance such as Machine functions etc.

In general **bold emphasis** is used to emphasize information of particular importance such as Machine commands, titles etc.

Change bars are also used in the document to indicate revisions. They are positioned in the left or right hand margins adjacent to the change.

At the end of the Manual there are a number of Appendices.

2.3 SYSTEM DESCRIPTION

The *Banner* MMD-TA-11B or MMD-TA-12B DIN Muting Module shown in [figure 2 on page 12](#), are an accessory component of a safeguarding system, which may incorporate such primary safeguards as safety light screens, safety interlocked gates/guards, or other presence-sensing safeguarding devices (PSSDs). The Module allows the machine to mute the primary safeguard by monitoring redundant inputs (two or four) and automatically suspend the safeguarding function of a safeguarding device during the non-hazardous portion of the machine cycle.

In this manual, the term “muting” refers to the automatic suspension of the safeguarding function of the primary safety device during a

non-hazardous portion of the machine cycle where personnel are not exposed to harm. A typical schematic layout is shown in [figure 11 on page 49](#). The muting function allows material to be manually or automatically fed into or removed from a machine process, without tripping the primary safeguard. The Module accomplishes this by using diverse-redundant microprocessors that monitor the status of inputs and outputs, so that a single fault causes the Module to issue a stop command to the machine. The Module, like all *Banner* safety products, is extensively FMEA (Failure Mode and Effects Analysis) tested to establish an extremely high degree of confidence that no internal component will, even if it does fail, cause a failure to danger. This design philosophy aids machine designers to comply with worldwide standards of control reliability for the highest level of safety.

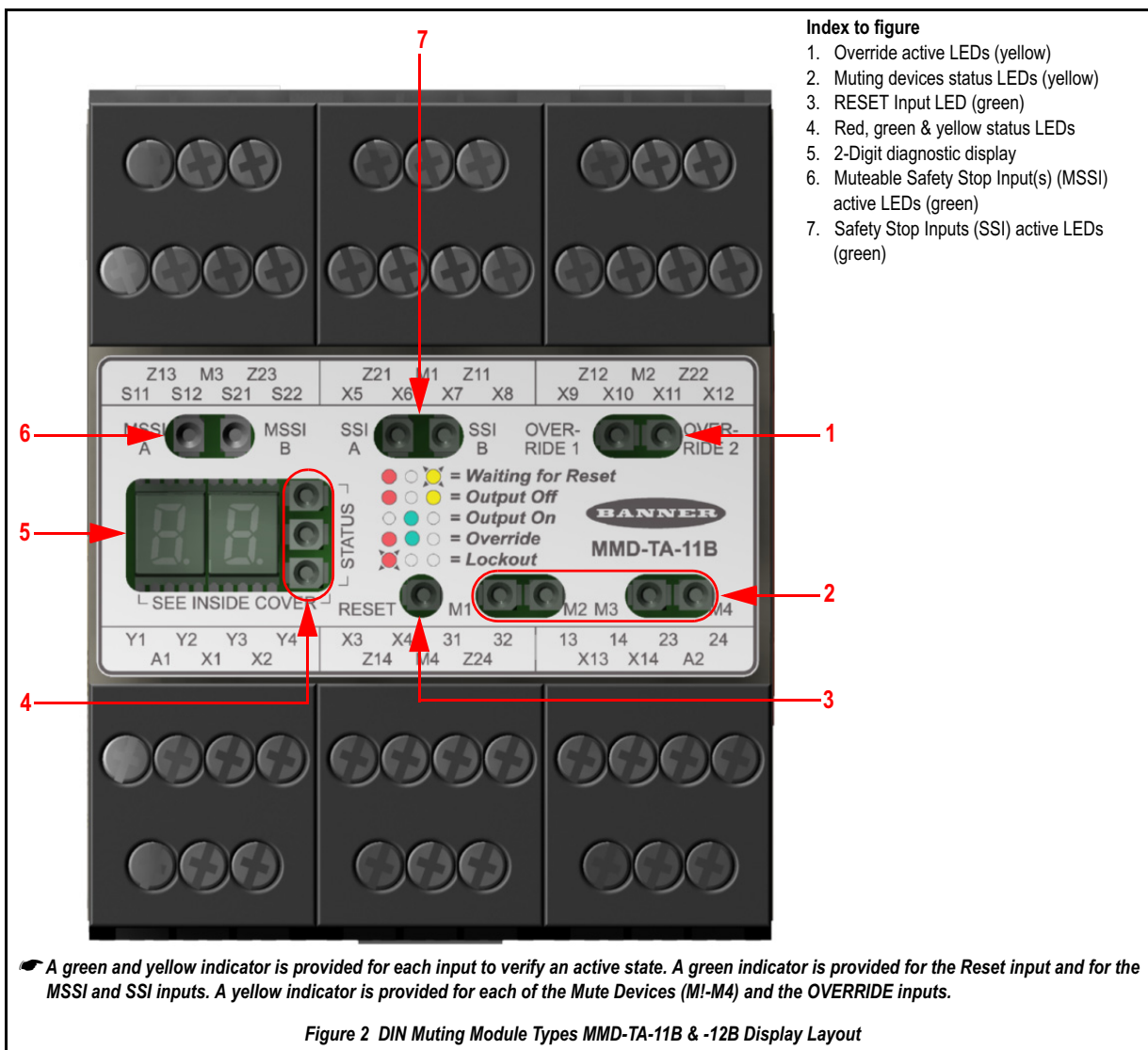

2.3.1 Operating LEDs & Diagnostic Display

The Module has three Operating Status LEDs (one each red, yellow and green), plus a 2-digit Diagnostic Display, visible through a window in the front cover. The individual LEDs provide constant, ongoing system status information at a glance. The Diagnostic Display provides error codes that correspond to the cause of a fault or configuration error which results in a lockout, and other more detailed conditions. See [Chapter 5 on Page 37](#) and [block 6.2.1 on page 45](#) for further information.

2.3.2 Typical Muting Applications

WARNING!

MUTING LIMITATIONS

MUTING IS ALLOWED ONLY DURING THE NON-HAZARDOUS PORTION OF THE MACHINE CYCLE. A MUTING APPLICATION MUST BE DESIGNED SO THAT NO SINGLE COMPONENT FAILURE CAN PREVENT THE STOP COMMAND OR ALLOW SUBSEQUENT MACHINE CYCLES UNTIL THE FAILURE IS CORRECTED AS PER ISO/DIS 13855 (2002).

USER IS RESPONSIBLE FOR SAFE APPLICATION OF THIS PRODUCT

THE MUTING APPLICATION EXAMPLES DESCRIBED IN [appendix A3 on page 61](#) DEPICT GENERALIZED GUARDING SITUATIONS. EVERY SAFEGUARDING APPLICATION HAS A UNIQUE SET OF REQUIREMENTS. EXTREME CARE IS URGED TO ENSURE THAT ALL LEGAL REQUIREMENTS ARE MET AND THAT ALL INSTALLATION INSTRUCTIONS ARE FOLLOWED. IN ADDITION, ANY QUESTIONS REGARDING SAFEGUARDING SHOULD BE DIRECTED TO THE [Corporate Office as listed on page 69](#).

The following are typical applications where muting is used. See [appendix on page 61](#) for more detailed information.

2.3.2.1 Entry/Exit Applications

The muting devices are placed to allow the entry or exit of a pallet or cart of work materials to enter or exit a workstation without tripping the safety light screen, and without allowing the entrance of personnel into the hazardous area (see [Entry/Exit Applications on page 61](#)).

2.3.2.2 Robot Load/Unload Station Application

The Station muting application uses independent safety light screen circuits, each with its own muting circuit and sensors to protect work locations. When a robot is active in Station A, for example: Station B safety light screen is muted (see [Robot Load/Unload Applications on page 63](#)).

2.3.2.3 Home or Station Application

The muting devices must be placed to mute the safety light screen only when a hazard does not exist or is in another area so that personnel are not exposed to any hazard.

2.3.2.4 Turret Table Application

A "Turret Table" application is similar to the Robot Load/Unload Station muting application, except that any movement of the table ends the mute.

2.3.2.5 Power Press Application

The muting devices are placed so that the mute is initiated only during the non-hazardous, opening portion of the cycle (typically the machine upstroke).

Intentionally Left Blank

3 GENERAL

This Chapter details information of a general nature on the equipment.

3.1 PRODUCT

This block details product information such as CE and Product Identification Plates together with their location.

3.1.1 CE Marking / Product Identification Plate

The CE information is combined with Product Identification Information as shown in figure 3 on page 15.

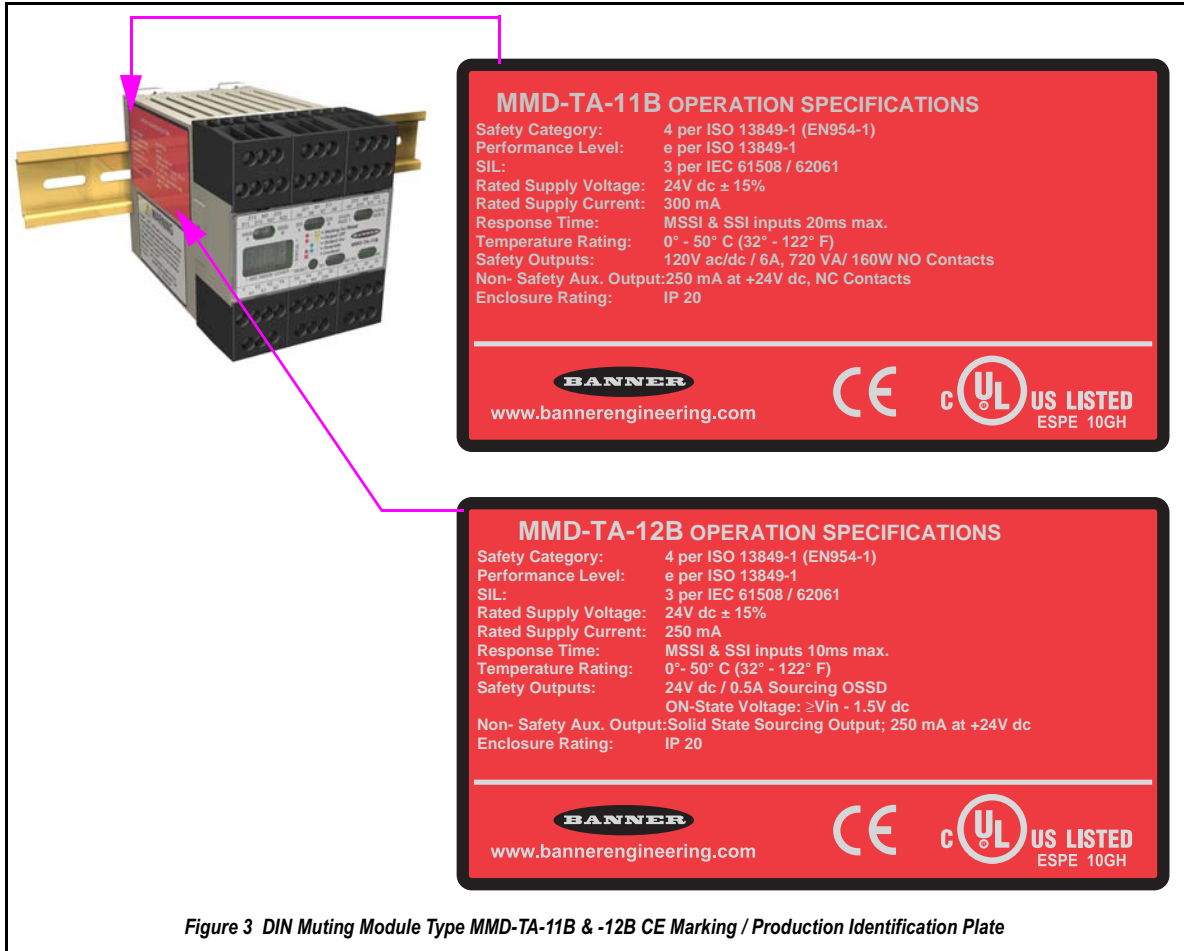

3.1.2 Certificate of Adequacy

The DIN Muting Module Instruction Manual (Part No. 132538 Dated 01.08.07) satisfies the requirements of: Machine Directive 98/37/EC, Safety of Machinery, Block 1.7.4 - Instructions.

3.1.3 Declaration of Conformity

The DIN Muting Module is delivered with a Declaration of Conformity as shown in figure 4 on page 16. This declaration is delivered to the Customer to certify that the product complies with the CE-Norm.

<h2 style="text-align: center; margin: 0;">Declaration of Conformity</h2> <table style="width: 100%; border: none;"> <tr> <td style="width: 50%; border: none;"> <p>Manufacturer: Address:</p> </td> <td style="width: 50%; border: none;"> <p>Banner Engineering Corp. 9714 10th Ave N. Minneapolis, MN 55441 USA</p> </td> </tr> <tr> <td style="border: none;"> <p>Herewith declares that:</p> <p>- is in conformity with the provisions of the Machinery Directive (Directive 98/37/EEC), and all Essential Health and Safety Requirements have been met.</p> <p>- is in conformity with the provisions of the following other EEC Directives:</p> </td> <td style="border: none;"> <p>Muting Module DIN</p> <p>89/336/EEC, 73/23/EEC</p> </td> </tr> <tr> <td style="border: none;"> <p>and that:</p> <p>- the following (parts/clauses of) harmonized standards, national technical standards and specifications have been used:</p> </td> <td style="border: none;"> <p>IEC 61496-1: 2004 ISO 13849-1: 2006 (Category 4, PL e) EN 954-1: 1996 (Category 4) EN 60204-1: 2006 EN 50178: 1997 IEC 61508 Part 1-7: 1998 and 2000 (SIL 3) IEC 62061: 2005 (SIL CL 3)</p> </td> </tr> <tr> <td style="border: none;"> <p>Approval Agency:</p> </td> <td style="border: none;"> <p>TUV Rheinland Industry Service GmbH Certificate: #968/EL 460.00/07 6/28/07</p> </td> </tr> </table> <p style="font-size: small; margin-top: 10px;">I, the undersigned, hereby declare that the equipment specified above conforms to the above Directive(s) and Standard(s).</p> <div style="display: flex; justify-content: space-between; margin-top: 10px;"> <div style="text-align: center;"> _____ <small>R. Eagle / Engineering Manager</small> </div> <div style="text-align: center;"> <p>07 09 2007</p> _____ <small>Date</small> </div> </div>	<p>Manufacturer: Address:</p>	<p>Banner Engineering Corp. 9714 10th Ave N. Minneapolis, MN 55441 USA</p>	<p>Herewith declares that:</p> <p>- is in conformity with the provisions of the Machinery Directive (Directive 98/37/EEC), and all Essential Health and Safety Requirements have been met.</p> <p>- is in conformity with the provisions of the following other EEC Directives:</p>	<p>Muting Module DIN</p> <p>89/336/EEC, 73/23/EEC</p>	<p>and that:</p> <p>- the following (parts/clauses of) harmonized standards, national technical standards and specifications have been used:</p>	<p>IEC 61496-1: 2004 ISO 13849-1: 2006 (Category 4, PL e) EN 954-1: 1996 (Category 4) EN 60204-1: 2006 EN 50178: 1997 IEC 61508 Part 1-7: 1998 and 2000 (SIL 3) IEC 62061: 2005 (SIL CL 3)</p>	<p>Approval Agency:</p>	<p>TUV Rheinland Industry Service GmbH Certificate: #968/EL 460.00/07 6/28/07</p>	<h2 style="text-align: center; margin: 0;">Declaration of Conformity</h2> <h3 style="text-align: center; margin: 5px 0;">Attached Schedule</h3> <p style="text-align: center; margin: 0;">Muting Module Din</p> <table style="width: 100%; border: none; margin-top: 10px;"> <tr> <td style="width: 50%; border: none; vertical-align: top;"> <p>Models covered by this Declaration of Conformity:</p> </td> <td style="width: 50%; border: none; vertical-align: top;"> <p>MMD-TA-11B MMD-TA-12B</p> </td> </tr> </table>	<p>Models covered by this Declaration of Conformity:</p>	<p>MMD-TA-11B MMD-TA-12B</p>
<p>Manufacturer: Address:</p>	<p>Banner Engineering Corp. 9714 10th Ave N. Minneapolis, MN 55441 USA</p>										
<p>Herewith declares that:</p> <p>- is in conformity with the provisions of the Machinery Directive (Directive 98/37/EEC), and all Essential Health and Safety Requirements have been met.</p> <p>- is in conformity with the provisions of the following other EEC Directives:</p>	<p>Muting Module DIN</p> <p>89/336/EEC, 73/23/EEC</p>										
<p>and that:</p> <p>- the following (parts/clauses of) harmonized standards, national technical standards and specifications have been used:</p>	<p>IEC 61496-1: 2004 ISO 13849-1: 2006 (Category 4, PL e) EN 954-1: 1996 (Category 4) EN 60204-1: 2006 EN 50178: 1997 IEC 61508 Part 1-7: 1998 and 2000 (SIL 3) IEC 62061: 2005 (SIL CL 3)</p>										
<p>Approval Agency:</p>	<p>TUV Rheinland Industry Service GmbH Certificate: #968/EL 460.00/07 6/28/07</p>										
<p>Models covered by this Declaration of Conformity:</p>	<p>MMD-TA-11B MMD-TA-12B</p>										

Figure 4 Declaration of Conformity for DIN Muting Module Type MMD-TA-11B & -12B

Not Applicable to UK English Version

Figure 5 Declaration of Conformity for DIN Muting Module Type MMD-TA-11B & 12B Translated Version

3.2 TECHNICAL DATA

This block details the most important technical data for the product.

3.2.1 Specifications

Table 2 on Page 17 lists the specifications for the DIN Muting Module.

Table 2 DIN Muting Module General Specifications

Nomenclature	Value/Meaning
System Power Requirements	<p>Model MMD-TA-11B: +24 VDC ±15% @ 300 mA max (SELV/PELV) Model MMD-TA-12B: +24 VDC ±15% @ 250 mA max (SELV/PELV) (not including draw of the MSSl power, AUX, ML, M1-M4 and OSSD connections) The external voltage supply must be capable of buffering brief mains interruptions of 20 ms, as specified in IEC/EN 60204-1.</p>
Overvoltage Category	III (IEC 60664-1)
Pollution Degree	2
Supply Protection Circuitry	All inputs and outputs are protected from short circuit to +24 VDC or DC common.
Response Time (MSSI and SSI)	<p>Model MMD-TA-11B: (relay output) 20 ms max. Model MMD-TA-12B: (solid-state output) 10 ms max.</p>
Safety Outputs (see WARNING on page 33 & WARNING on page 49)	<p>Model MMD-TA-11B: 2 normally open contact output channels and 1 normally closed auxiliary contact output channel: Each normally open output channel is a series connection of contacts from two forced-guided (positive-guided) relays, K1-K2. The normally closed AUX contact (non-safety) 31-32 is a parallel connection of contacts from K1-K2. Contacts: AgNi, 5 µm gold-plated</p> <div style="border: 2px solid red; padding: 10px; text-align: center; margin: 10px 0;">  <p>WARNING! THE 5 µm GOLD-PLATED CONTACTS ALLOW THE SWITCHING OF LOW CURRENT/LOW VOLTAGE</p> </div> <p>To preserve the gold plating on the contacts, the following max. values should not be exceeded at any time: Low Current Rating: In these low-power applications, multiple contacts can also be switched in series (e.g., "dry switching"). Min. voltage: 1 VAC/DC Max. voltage: 60V Min. current: 5 mA AC/DC Max. current: 300 mA Min. power: 5 mW (5 mVA) Max. power: 7 W (7 VA)</p> <p>High Current Rating: If higher loads must be switched through one or more of the contacts, the minimum and maximum values of the contact(s) changes to: Min. voltage: 15 VAC/DC Max. voltage: 120 VAC/DC Min. current: 30 mA AC/DC Max. current: 6 A Min. power: 0,45 W (0,45 VA) Max. power: 160 W (720 VA)</p> <p>Mechanical life: 50,000,000 operations Electrical life: 20,000 operations (typical, @ 144 W [1,380 VA] switched power, resistive load) ⚡ <i>Transient suppression is recommended when switching inductive loads. Install suppressors across load. Never install suppressors across output contacts (see WARNINGS OSSD Interfacing, Proper Wiring, High Voltage Shock Hazard for Model MMD-TA-11B and Use of Transient Suppressors on page 49).</i></p>
	<p>Model MMD-TA-12B: 2 diverse-redundant solid-state safety outputs: 24 VDC, 0,5 A sourcing OSSD (output signal switching device) ON-State voltage: > Vin-1,5 VDC OFF-State voltage: 1,2 VDC max. (0 VDC-1,2 VDC) Max. load capacitance: 1,0 µF Max. load inductance: 10 H Leakage current: 0,50 mA maximum Cable resistance: 10 ohms maximum OSSD test pulse width: less than 100 µs OSSD test pulse period: more than 100 milliseconds Switching current: 0 A-0,5 A</p>

Table 2 DIN Muting Module General Specifications



Nomenclature	Value/Meaning
Non-Safety Outputs	<p>Model MMD-TA-11B: Aux. output 31–32 is a parallel connection of two N.C. contacts from internal relays K1 and K2. Contact: AgNi, 5 μ gold-plated</p> <div style="border: 2px solid red; padding: 5px; text-align: center; margin: 10px 0;">  WARNING! THE 5 μM GOLD-PLATED CONTACTS ALLOW THE SWITCHING OF LOW CURRENT/LOW VOLTAGE. </div> <p>To preserve the gold plating on the contacts, the following max. values should not be exceeded at any time: Low Current Rating: Min. voltage: 1 VAC/DC Max. voltage: 24 VAC/DC Min. current: 5 mA AC/DC Max. current: 250 mA AC/DC Min. power: 5 mW (5 mVA) Max. power: 6W (6 VA)</p> <p>High Current Rating: For higher loads, the min. and max. values of the contact(s) changes to: Min. voltage: 15 VAC/DC Max. voltage: 24 VAC/DC Min. current: 30 mA AC/DC Max. current: 250 mA AC/DC Min. power: 0,45 W (0,45 VA) Max. power: 6 W (6 VA)</p> <p>Mechanical life: 50,000,000 operations Electrical life: >10 x 10⁶ cycles</p> <p>Model MMD-TA-12B: Z4–Z3 = Aux. 24V / 250 mA PNP output follows the two OSSD safety outputs.</p>
Status Indicator LEDs	<p>Status Indicator LEDs x3 (red, green and yellow): indicate waiting for Reset, Lockout, Override, and OSSD status Yellow and Green LEDs adjacent to individual inputs/interfaces indicate status (ON = active/closed)</p>
Diagnostic Code Display	<p>Diagnostic Display is a two-digit numeric display that indicates the cause of lockout conditions and the amount of time remaining for the backdoor timer.</p>
Muting Lamp Output	<p>A monitored or non-monitored (selectable) sinking output. If monitoring has been selected, the current draw must be 10 mA to 360 mA. Interconnect wire resistance < 30 ohms. Maximum Switching Voltage: 30 VDC Maximum Switching Current: 360 mA Minimum Switching Current: 10 mA Saturation Voltage: < 1,5 VDC @ 10 mA; < 5 VDC @ 360 mA</p>
Controls and Adjustments	<p>Configured on x2 redundant banks of DIP switches: Manual/auto reset One-way/two-way muting Monitored/non-monitored mute lamp output One channel/two channel/no EDM Backdoor timer Mute on power-up enable</p>
Inputs	<p>The MSSI and the SSI can be interfaced with external devices that have either hard contact outputs or solid state sourcing outputs. When connecting the MSSI (S11–S12, S21–S22) or SSI (X5–X6, X7–X8) inputs to relay outputs or hard contacts, these contacts must be capable of switching 15 VDC–30 VDC at 10 mA–50 mA.</p> <p>Operating Range for MSSI and SSI Inputs OFF State: -3 V to +5 V, 0 to 2 mA ON State: 15 V–30 V, 10–50 mA</p> <p>Muteable Safety Stop Interface (MSSI) This input consists of two channels (MSSI-A and MSSI-B), and can be muted when the requirements for a mute cycle have been met. When muted, the OSSDs remain ON, independent of the MSSI status. If not muted, anytime either or both channels open, the OSSD outputs go OFF. Maximum external resistance per channel must not exceed 400 Ω. (See block 4.5.5 on page 26 for further information.)</p> <p>Safety Stop Interface (SSI) This input consists of two channels (SSI-A and SSI-B), and is always active. Any time either or both channels open, the OSSD Outputs go OFF. Maximum external resistance per channel must not exceed 400 Ω. (See block 4.5.5 on page 26 for further information.)</p>
External Device Monitoring EDM	<p>Two pairs of terminals are provided to monitor the state of external devices controlled by the OSSD outputs. Each device must be capable of switching 15 VDC to 30 VDC at 10 mA to 50 mA.</p>
Muting Device Inputs	<p>The muting devices work in pairs (M1 and M2, M3 and M4) and are required to be “closed” within 3 s of each other (Simultaneity Requirement, see page 67 /synchronous actuation) to initiate a mute (assuming all other conditions are met). Each muting device must be capable of switching 15 VDC–30 VDC at 10 mA–50 mA.</p>

Table 2 DIN Muting Module General Specifications

Nomenclature	Value/Meaning
Mute Enable Input	The Mute Enable input must have +24 VDC applied in order to start a mute; opening this input after mute has begun has no effect. If Mute Enable is disabled, this input is ignored and a mute cycle can occur regardless of the state of the mute enable input. The switching device must be capable of switching 15 VDC–30 VDC at 10 mA–50 mA.
Override Inputs	The two-channel inputs must be closed within 3 s of each other (Simultaneity Requirement, see page 67 /synchronous action requirement) and held closed during the 30-second Override. To initiate a subsequent Override, open both channels, wait 3 s, and then re-close both channels (within 3 s). The switching devices must be capable of switching 15 VDC–30 VDC at 10 mA–50 mA.
Reset Input	Terminals must be closed for a minimum of 0,25 s and not more than 2,0 s in order to guarantee a reset. The switching device must be capable of switching 15 VDC to 30 VDC at 10 mA to 50 mA.
Mounting	Mounts to standard 35 mm DIN-rail track; see figure 6 on page 20 .
Vibration Resistance	10 to 55 Hz @ 0,35 mm displacement per IEC 68-2-6.
Construction	Polycarbonate housing. See block 3.2.3 on page 20 for dimensions.
Environmental Rating	Rated IEC IP20. Safety Module must be installed inside an enclosure rated IEC IP54 or better.
Connections	Removable terminal blocks; see figure 8 on page 23 and table 3 on page 19 for terminal locations.
Operating Conditions	Temperature range: 0° C to +50° C Max. Relative Humidity: 95% (non-condensing) Heat Dissipation Considerations: See block 4.2 on page 21 "Installing the Module".
Safety Category*	Safety Category 4 per ISO 13849-1 (EN954-1) compliance, dependent on connection. See block 4.5.5 on page 26 .
Safety Integrity Level (SIL)*	SIL 3 as per IEC 61508 Part 1-7 & SIL CL 3 as per IEC 62061
Certifications	
Application Notes	Mute Timing Sequences: See appendix A1 on page 49 Typical Muting Applications: See appendix A2 on page 59 Application Standards: See block 1.4 on page 2

*Contact the factory for IEC 61508/62061 and ISO 13849-1 data.

3.2.2 Model/Type Numbering

Refer to [table 3 on page 19](#).

Included with the DIN Muting Module are the following documents (for order numbers see [table 10 on page 47](#)):

- Instruction Manual (this document)

3.2.2.1 DIN Muting Module Model/Type Numbering

Table 3 DIN Muting Module

Model No.	Description	Order No.	Model
MMD-TA-11B	DIN Muting Module relay output (Category 4 per EN 954-1)	30 750 90	
MMD-TA-12B	DIN Muting Module solid state output (Category 4 per EN 954-1)	30 750 91	

3.2.3 DIN Muting Module Dimensions

figure 6 on page 20 gives the dimensions for the DIN Muting Module Types MMD-TA-11B & -12B.

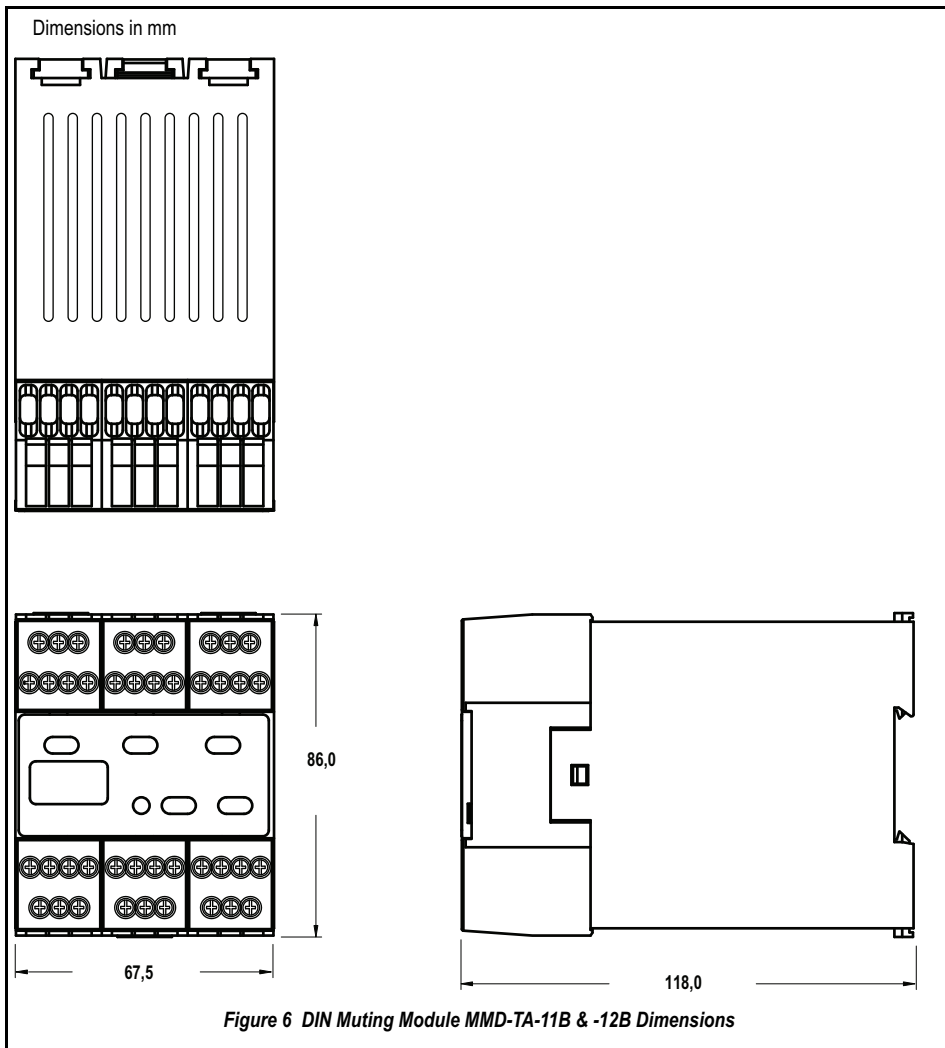

3.3 CUSTOMER SERVICE INFORMATION

For Customer service information refer to [appendix A5 on page 69](#).

4 INSTALLATION

WARNINGS!

BEFORE OPERATING THE EQUIPMENT

READ THE SAFETY INFORMATION CONTAINED IN [Chapter 1 on Page 1](#).

BEFORE INSTALLING THE EQUIPMENT

READ THE SAFETY INFORMATION CONTAINED IN [Chapter 1 on Page 1](#).

READ THIS SECTION CAREFULLY BEFORE INSTALLING THE SYSTEM

THE **BANNER DIN MUTING MODULE** IS AN ACCESSORY DEVICE THAT IS TYPICALLY USED IN CONJUNCTION WITH POINT OF OPERATION MACHINE SAFEGUARDING DEVICE(S). ITS ABILITY TO PERFORM THIS FUNCTION DEPENDS UPON THE APPROPRIATENESS OF THE APPLICATION AND UPON THE **DIN MUTING MODULE'S (MMD-TA-11B)** PROPER MECHANICAL AND ELECTRICAL INSTALLATION AND INTERFACING TO THE MACHINE TO BE SAFEGUARDED.

IF ALL MOUNTING, INSTALLATION, INTERFACING, AND CHECKOUT PROCEDURES ARE NOT FOLLOWED PROPERLY, THE **DIN MUTING MODULE** CANNOT PROVIDE THE PROTECTION FOR WHICH IT WAS DESIGNED. THE USER HAS THE RESPONSIBILITY THEREFORE TO ENSURE THAT ALL LOCAL, STATE, AND NATIONAL LAWS, RULES, CODES, OR REGULATIONS RELATING TO THE INSTALLATION AND USE OF THIS CONTROL SYSTEM IN ANY PARTICULAR APPLICATION ARE SATISFIED. EXTREME CARE SHOULD BE TAKEN TO ENSURE THAT ALL LEGAL REQUIREMENTS HAVE BEEN MET AND THAT ALL TECHNICAL INSTALLATION AND MAINTENANCE INSTRUCTIONS CONTAINED IN THIS MANUAL ARE FOLLOWED. READ [Chapter 4 on Page 21](#) (AND ITS SUBSECTIONS) OF THIS MANUAL CAREFULLY BEFORE INSTALLING THE SYSTEM. FAILURE TO FOLLOW THESE INSTRUCTIONS COULD RESULT IN SERIOUS BODILY INJURY OR DEATH. THE USER HAS THE SOLE RESPONSIBILITY TO ENSURE THAT THE **BANNER DIN MUTING MODULE** IS INSTALLED AND INTERFACED TO THE SAFEGUARDED MACHINE BY A [Qualified Person as specified in block 1.9 on Page 3](#).

4.1 PRE-INSTALLATION CONSIDERATIONS

4.1.1 Reducing or Eliminating Pass-Through Hazards

WARNING!

PASS-THROUGH HAZARDS, PSSDs & MUTING

IF THE **PSSD** (see [page 65](#)) IS SAFEGUARDING AN APPLICATION IN WHICH PERSONNEL HAVE ACCESS INTO THE SENSING AREA OR FIELD (FOR EXAMPLE: A MACHINE OPERATOR AT THE POINT OF OPERATION) WHILE THE **PSSD** IS MUTED, ALL PASS-THROUGH HAZARDS MUST BE ELIMINATED. THE INDIVIDUAL MUST BE SENSED CONTINUALLY WHILE IN THE SAFEGUARDED AREA. THIS PREVENTS INITIATION OF A MACHINE CYCLE IF THE MUTE ENDS WHILE THE INDIVIDUAL IS WITHIN THE HAZARDOUS AREA. SEE [appendix A2 on page 59](#) FOR EXAMPLES. IF THE PASS-THROUGH HAZARD CANNOT BE ELIMINATED, AS IN ENTRY/EXIT APPLICATIONS, THE INDIVIDUAL MUST BE DETECTED ENTERING THE SAFEGUARDED AREA AND THE HAZARDOUS MOTION MUST STOP IMMEDIATELY. SEE ALSO [block 1.11.15 on page 8](#).

Measures must be taken to eliminate or reduce pass-through hazards. One solution is to ensure that personnel are continually sensed while within the hazardous area. This can be accomplished by using supplementary guarding, including: safety mats, area scanners, and horizontally mounted safety light screens. While it is recommended to eliminate the pass-through hazard altogether, this may not be possible due to cell or machine layout, machine capabilities, or other application considerations.

An alternate method is to ensure that once the Safeguarding Device(s) is tripped it latches, and requires a deliberate manual action to reset. This type of supplementary guarding relies upon the location of the Reset Switch as well as safe work practices and procedures to prevent an unexpected start or restart of the safeguarded machine.

The Reset switch or actuating control must be positioned outside the safeguarded area, and provide the switch operator with a full unobstructed view of the entire safeguarded area and any associated hazards as the reset is performed. The Reset switch or actuating control must not be reachable from within the safeguarded area and must be protected (through the use of rings or guards) against unauthorized or inadvertent operation. A key-operated reset switch provides some operator control, as it can be removed by the operator and taken into the safeguarded area. However, this does not prevent unauthorized or inadvertent resets due to spare keys in the possession of others, or additional personnel entering the Safeguarding Device(s) area unnoticed.

The reset of a Safeguarding Device(s) must not initiate hazardous motion. Also, before each reset, safe work procedures require that a start-up procedure be followed and that the individual performing the reset verifies that the entire hazardous area is clear of all personnel. If any areas can not be observed from the Reset switch location, additional supplementary guarding must be used; at a minimum, visual and audible warnings of machine start-up.

4.2 INSTALLING THE DIN MUTING MODULE(S)

The DIN Muting Module mounts to a standard 35 mm DIN-rail track. The Module must be installed inside an enclosure rated IEC IP 54 or better. It can be mounted in any orientation. It must be used with a properly installed and applied safeguard (e.g., safety light screen, interlocked barrier guard). The user must comply with all instructions contained within product manuals and relevant regulations.

For reliable operation, the user must ensure that the operating specifications are not exceeded. The enclosure must provide adequate heat dissipation, so that the air closely surrounding the Module does not exceed its maximum operating temperature. Methods to reduce heat build-up include venting, forced air flow (e.g., exhaust fans), adequate enclosure exterior surface area, and spacing between Modules and other sources of heat (see Specifications, [Operating Conditions on page 19](#)).

Mount the Module in a convenient location that is free from heavy impulse force and high-amplitude vibration.

 *Electrostatic Discharge (ESD) can cause damage to electronic equipment. To prevent this, follow proper ESD handling practices such as:*

- *Wear an approved wrist strap or other approved grounding products.*
- *Touch a grounded object before handling the Module.*

For further information about managing ESD, refer to IEC 61340-5-1.

- 1) Mount DIN Muting Module in a convenient location that is free from heavy impulse force and high-amplitude vibration.

4.3 DIN MUTING MODULE(S) CONFIGURATION

The DIN Muting Module should be configured before Initial Checkout and use. Two banks of DIP switches are located under the front cover (figure 7 on page 22).

Because the DIN Muting Module has redundant microprocessors, two DIP switch banks (Bank A and Bank B) must be set identically. Failure to set Bank A and Bank B identically results in a lockout condition.

Power must be OFF when changing DIP switch settings. Changing settings while power is ON causes a lockout condition.

The parameters to be manually configured are shown in table 4 on page 22.

To configure the DIP switches:

- 1) Ensure power is OFF to DIN Muting Module.

- 2) Using a screwdriver, gently ease off front cover.



- 3) Set both banks of DIP switches on factory default settings as shown in figure 7 on page 22.

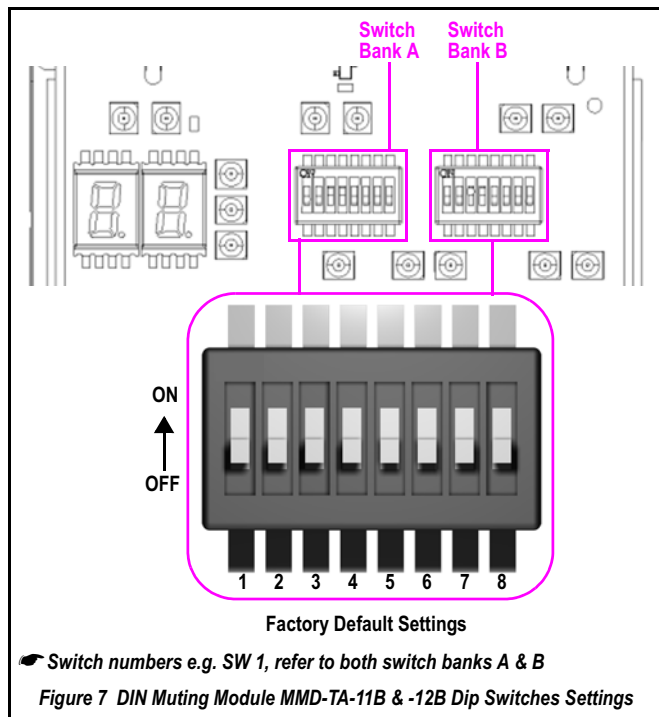

Table 4 DIP Switch Configuration

Function	ON Position	OFF Position
1 Auto/Manual MSSl Reset (see block 1.11.1 on page 4).	MSSl Auto Reset	MSSl Manual Reset*
2 Auto/Manual SSl Reset (see block 1.11.1 on page 4).	SSl Auto Reset	SSl Manual Reset*
3 One-Way or Two-Way Mute Initiate Sequence (see block 1.11.12 on page 8)	Two-way muting	One-way muting*
4 One-Channel or Two-Channel EDM (see block 1.11.6 on page 6)	One-Channel EDM	Two-Channel EDM*
5-6 Backdoor Time-Out (see block 5.1.2.1 on page 37)	5 ON, 6 ON	5 ON, 6 OFF
	No backdoor time-out (infinite)	30 min. backdoor time-out
	5 OFF, 6 ON	5 OFF, 6 OFF
	60 s backdoor time-out	30 s backdoor time-out*
7 Non-Monitored Mute Lamp Output (see block 1.11.9 on page 7)	Mute lamp not monitored	Mute lamp monitored*
8 Mute on Power-Up (see block 1.11.10 on page 7)	Mute on power-up	No mute on power up*

* Factory default setting

4.4 TERMINAL BLOCK CONNECTION & FUNCTIONS

⚡ WARNINGS!

HIGH VOLTAGE SHOCK HAZARD FOR MODEL MMD-TA-11B ONLY

ALWAYS DISCONNECT ALL POWER FROM THE MUTING MODULE AND THE GUARDED MACHINE BEFORE MAKING ANY CONNECTIONS OR REPLACING ANY COMPONENT. USE EXTREME CAUTION TO AVOID ELECTRICAL SHOCK AT ALL TIMES. SERIOUS BODILY INJURY OR DEATH COULD RESULT.

PROPER ELECTRICAL CONNECTION

ELECTRICAL CONNECTION MUST BE MADE BY QUALIFIED PERSONNEL AND MUST COMPLY WITH LOCAL ELECTRICAL STANDARDS. DO NOT MAKE CONNECTIONS TO THE SYSTEM OTHER THAN THOSE DESCRIBED IN Chapter 4 on Page 21 OF THIS MANUAL. DOING SO COULD RESULT IN SERIOUS INJURY OR DEATH.

The DIN Muting Module is electrically connected via the x6 removable terminal blocks as shown in figure 8 on page 23.

The terminal blocks can be removed for connection by gently easing out with a screwdriver.

Identification of the terminals are shown in table 5 on page 23 and table 6 on page 24).

To disable the SSI, terminal X5 (SS1b) must be jumpered to terminal X6 (SS1a), and terminal X7 (SS1d) must be jumpered to terminal X8 (SS1c) (factory default).

Do **not** short Channel A to Channel B.

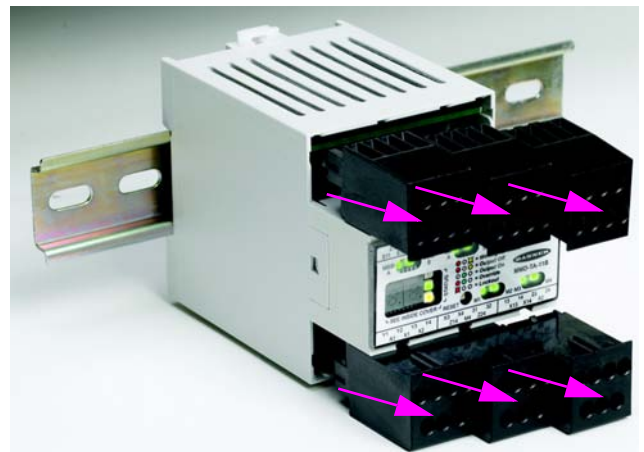

Figure 8 DIN Muting Module Terminal Blocks Extended

Table 5 MMD-TA-11B Terminal Connection Locations

Terminal	Function	Terminal	Function	Terminal	Function
Z13	M3, 0 V	Z21	M1, 24V	Z12	M2, 0V
M3	Muting 3 In (PNP)	M1	Muting 1 In (PNP)	M2	Muting 2 In (NPN)
Z23	M3, 24 V	Z11	M1, 0V	Z22	M2, 24V
S11	MSSI b (ch A)	X5	SSI b (ch A)	X9	Override a (ch A)*
S12	MSSI a (ch A)	X6	SSI a (ch A)	X10	Override b (ch A)*
S21	MSSI d (ch B)	X7	SSI d (ch B)	X11	Override c (ch B)*
S22	MSSI c (ch B)	X8	SSI c (ch B)	X12	Override d (ch B)*
Y1	EDM 1 a Out (24V)	X3	Mute Lamp Out (24V)	13	OSSD 1 a (Relay)
Y2	EDM 1 b In	X4	Mute Lamp In	14	OSSD 1 b (Relay)
Y3	EDM 2 b In	31	AUX a (Relay)	23	OSSD 2 a (Relay)
Y4	EDM 2 a Out (24V)	32	AUX b (Relay)	24	OSSD 2 b (Relay)
A1	+24V dc	Z14	M4, 0V	X13	Mute Enable Out (24 V)
X1	Reset In	M4	Muting 4 In (NPN)	X14	Mute Enable In
X2	Reset Out (24V)	Z24	M4, 24V	A2	0 VDC

*Contacts only

All terminals are low voltage except for those indicated otherwise

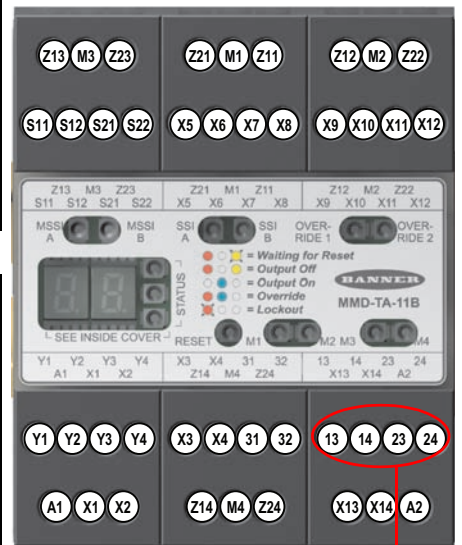

Potential high voltage terminals

Table 6 MMD-TA-12B Terminal Connection Locations

Terminal	Function	Terminal	Function	Terminal	Function
Z13	M3, 0 V	Z21	M1, 24V	Z12	M2, 0V
M3	Muting 3 In (PNP)	M1	Muting 1 In (PNP)	M2	Muting 2 In (NPN)
Z23	M3, 24 V	Z11	M1, 0V	Z22	M2, 24V
S11	MSSI b (ch A)	X5	SSI b (ch A)	X9	Override a (ch A)*
S12	MSSI a (ch A)	X6	SSI a (ch A)	X10	Override b (ch A)*
S21	MSSI d (ch B)	X7	SSI d (ch B)	X11	Override c (ch B)*
S22	MSSI c (ch B)	X8	SSI c (ch B)	X12	Override d (ch B)*
Y1	EDM 1 a Out (24V)	X3	Mute Lamp Out (24V)	Y5	OSSD 1 a Out
Y2	EDM 1 b In	X4	Mute Lamp In	Y6	OSSD 1 b 0 V
Y3	EDM 2 b In	Z3	AUX a (Relay)	Y7	OSSD 2 b 0 V
Y4	EDM 2 a Out (24V)	Z4	AUX b (Relay)	Y8	OSSD 2 a Out
A1	+24V dc	Z14	M4, 0V	X13	Mute Enable Out (24 V)
X1	Reset In	M4	Muting 4 In (NPN)	X14	Mute Enable In
X2	Reset Out (24V)	Z24	M4, 24V	A2	0 VDC

*Contacts only

All terminals are low voltage

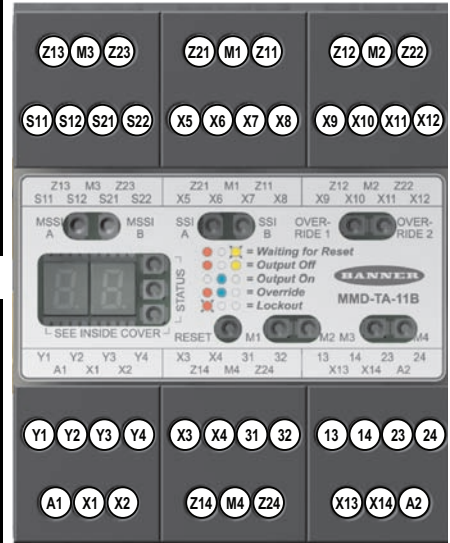

4.5 CONNECTING INPUT DEVICES

4.5.1 Manual Reset Switch

Refer to [block 5.1.2.2 on page 38](#).

4.5.1.1 Reset Routine

The DIN Muting Module requires a Manual Reset to clear a latch condition and resume operation following a stop command.

To reset the system proceed as follows:

- 1) If using a non *Banner* supplied Reset Switch, close Reset Switch for 0,25 s to 2 s, then open switch again. If using a *Banner* supplied Reset Switch (type MGA-KS0-1 [table 9 on page 47](#) refers), turn key 1/4 turn clockwise, hold for 0,25 s to 2 s, then turn key counter clockwise to its original position.

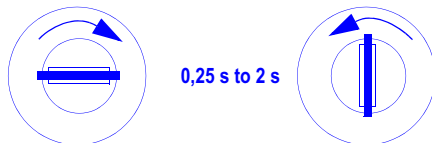

Internal lockout conditions also require a Manual Reset to return the system to RUN mode after the failure has been corrected and the input correctly cycled.

4.5.2 Muting Devices

The User is required by European standards to arrange, install, and operate the safety system so as to protect personnel and minimize the possibility of defeating the Safeguarding Device(s).

Indication that the Safeguarding Device(s) is muted must be provided and be readily observable (as per ISO/DIS 13855). Failure of this indication should be detectable and prevent the DIN Muting Module from initiating a mute cycle. If this is not possible, the operation of the indicator should be verified at suitable intervals. Mute devices must meet the [Simultaneity Requirement](#), see [page 67](#) to activate muting.

4.5.2.1 General Muting Device Requirements

See [General Muting Device Requirements on page 7](#).

4.5.2.2 Examples of Muting Sensors & Switches

WARNING!

AVOID HAZARDOUS INSTALLATIONS

TWO OR FOUR INDEPENDENT POSITION SWITCHES (AT M1-M2 OR M3-M4) MUST BE PROPERLY ADJUSTED OR POSITIONED SO THAT THEY CLOSE ONLY AFTER THE HAZARD NO LONGER EXISTS, AND OPEN AGAIN WHEN THE CYCLE IS COMPLETE OR THE HAZARD IS AGAIN PRESENT. IF IMPROPERLY ADJUSTED OR POSITIONED, INJURY OR DEATH COULD RESULT. THE USER HAS THE RESPONSIBILITY TO SATISFY ALL LOCAL, STATE, AND NATIONAL LAWS, RULES CODES, AND REGULATIONS RELATING TO THE USE OF SAFETY EQUIPMENT IN ANY PARTICULAR APPLICATION. IT IS EXTREMELY IMPORTANT TO BE SURE THAT ALL APPROPRIATE AGENCY REQUIREMENTS HAVE BEEN MET AND THAT ALL INSTALLATION AND MAINTENANCE INSTRUCTIONS CONTAINED IN THE APPROPRIATE MANUALS ARE FOLLOWED.

Photoelectric Sensors (Opposed Mode)

Opposed-mode sensors, which initiate the muted condition when the beam path is blocked, should be configured for dark operate and have open (non-conducting) output contacts in a power OFF condition.

 Both the Emitter and Receiver from each pair should be powered from the same source, to eliminate common mode failures.

Photoelectric Sensors (Polarized Retro reflective Mode)

The User must ensure that false proxing (activation due to shiny or reflective surfaces) is not possible. *Banner* LP sensors with linear polarization can greatly reduce or eliminate this effect.

Configure sensors for Light Operate (LO or N.O.) if initiating a mute when the retro reflective target or tape is detected (for example: home position). Configure sensors for Dark Operate (DO or N.C.) when a blocked beam path initiates the muted condition (for example: entry/exit). Both situations must have open (non-conducting) output contacts in a power OFF condition.

Positive-opening Safety Switches

Two (or four) independent switches, each with a minimum of one closed safety contact to initiate the mute cycle are typically used. An application using a single switch with a single actuator and two closed contacts could result in an unsafe situation.

Inductive Proximity Sensors

Typically, inductive proximity sensors are used to initiate a muted cycle when a metal surface is detected. Due to excessive leakage current causing false ON conditions, two-wire sensors are **not** to be used. Only three- or four-wire sensors that have discrete PNP, NPN, or hard-contact outputs that are separate from the input power can be used.

4.5.2.3 Muting Device Connection

The DIN Muting Module provides supply voltage, if required, and input connections for the muting devices. One or two pairs of muting devices (typically sensors or switches) must be used; these pairs are designated M1-M2 and M3-M4. The M1 and M3 inputs are PNP (sourcing). The M2 and M4 inputs are NPN (sinking). Also available are terminals to supply power (+24 VDC) to the muting devices.

The current draw of all devices must not exceed 500 mA.

Typical examples are shown in [figure 18 on page 53](#), [figure 19 on page 53](#) and [figure 20 on page 54](#).

4.5.3 Mute Lamp Output & Auxiliary Output

The DIN Muting Module provides connection terminals for the Mute Lamp (ML) output and an Auxiliary output (AUX) (see [figure 21 on page 54](#), [figure 22 on page 54](#) & [figure 23 on page 54](#)).

4.5.3.1 Mute Lamp Output (ML)

The Mute Lamp output provides for the visible indication that the safety device's safeguarding function is muted. This indication must be readily observable. Failure of this indication should be detectable and prevent the safeguard from being muted, or the operation of the indicator should be verified at suitable intervals (see [block 1.11.9 on page 7](#)). The Mute Lamp output also flashes to indicate an Override condition (see also [block 1.11.11 on page 8](#)).

The DIN Muting Module can be configured for a Monitored or Non-Monitored mute lamp (ML) (see [table 4 on page 22](#)). This output may also be used as an input to control logic (for example: a PLC) if Non-Monitored is selected (SW7 = ON, bank A and bank B). The current draw of the mute lamp must not exceed 360 mA (see [figure 21 on page 54](#)). See also [block 1.11.9 on page 7](#).

4.5.3.2 Auxiliary Output (AUX)

Model MMD-TA-11B: The non-safety-related output on this model is a 24V ac/dc, 250 mA normally-closed relay contact. See Specifications [table 2 on page 17](#). See [figure 22 on page 54](#).

Model MMD-TA-11B: A non-safety-related PNP output is available at terminals Z3–Z4. This monitoring output is for light-duty, non-safety-related control functions, such as an input to a PLC. This output follows the OSSD outputs. Maximum current draw of the AUX output is 250 mA (see [figure 23 on page 54](#)).

4.5.4 Override Switch Connection

WARNING!

LIMITING USE OF OVERRIDE FUNCTION

THE OVERRIDE FUNCTION IS NOT FOR MACHINE SETUP OR PRODUCTION. IT IS TO BE USED ONLY TO CLEAR THE PRIMARY SAFETY DEVICE, SUCH AS IF MATERIAL BECOMES STUCK IN THE DEFINED AREA OF A SAFETY LIGHT SCREEN. WHEN OVERRIDE IS USED, IT IS THE USER'S RESPONSIBILITY TO INSTALL AND USE IT ACCORDING TO CURRENT SAFETY STANDARDS (SEE [block 1.4 on page 2](#)). IN ADDITION, THE REQUIREMENTS LISTED IN STANDARD IEC/EN60204-1 BLOCK 9.2.4 MUST BE SATISFIED.

The DIN Muting Module provides connection terminals for the Override switches (see [figure 24 on page 54](#)). See [block 1.11.11 on page 8](#) before connecting switches.

4.5.5 SSI & MSSSI Interfacing

WARNING!

EMERGENCY STOP FUNCTIONS

DO NOT CONNECT ANY EMERGENCY STOP DEVICES TO THE MSSSI INPUT; DO NOT MUTE OR BYPASS ANY EMERGENCY STOP DEVICE. IEC/EN 60204-1 REQUIRES THAT THE EMERGENCY STOP FUNCTION REMAINS ACTIVE AT ALL TIMES. MUTING OR BYPASSING THE SAFETY OUTPUTS RENDERS THE EMERGENCY STOP FUNCTION INEFFECTIVE.

The SSI provides for easy integration of Safeguarding Device(s). This interface consists of two input channels (A & B), which are compatible with *Banner* safety devices that have solid-state OSSD outputs or other devices with sourcing +24V dc outputs. SSI is also compatible with devices that have normally open hard contacts or relay outputs (voltage-free).

The MSSSI input is a specialized SSI that can be muted during the non-hazardous portion of the machine cycle and provides +24 VDC supply power to the primary Safeguarding Device(s) that is to be muted.

The input channels (A & B) must meet the [Simultaneity Requirement, see page 67](#) of 3 s upon closing and opening. A mismatch of more than 3 seconds results in a lockout. A lockout that is due to a failure to meet the [Simultaneity Requirement, see page 67](#) can only be cleared by:

- Cycling the MSSSI (or the SSI, depending on which failed) with simultaneity being met, and then
- Providing the Module is configured for Manual Reset, performing a reset routine

The MSSSI and the SSI can be interfaced with devices with solid-state OSSD outputs, safety interlocking switches, E-stop buttons, rope/cable pull devices, and other machine control devices that switch +24Vdc. To be interfaced with a safety mat, a safety mat controller must be connected between the mat and the interface (see [figure 25 on page 55](#)).

 *If the SSI is not to be used, the input channels must be jumpered (see [block 4.4 on page 23](#)).*

4.5.5.1 Safety Circuit Integrity & ISO 13849-1 (EN954-1)

WARNING!

SSI AND MSSSI SAFETY CATEGORIES

THE LEVEL OF SAFETY CIRCUIT INTEGRITY CAN BE GREATLY IMPACTED BY THE DESIGN AND INSTALLATION OF THE SAFETY DEVICES AND THE MEANS OF INTERFACING OF THOSE DEVICES. A RISK ASSESSMENT MUST BE PERFORMED TO DETERMINE THE APPROPRIATE SAFETY CIRCUIT INTEGRITY LEVEL OR SAFETY CATEGORY AS DESCRIBED BY ISO 13849-1 (EN 54-1) TO ENSURE THAT THE EXPECTED RISK REDUCTION IS ACHIEVED AND THAT ALL RELEVANT REGULATIONS ARE COMPLIED WITH.

Safety Circuit Principles

Safety circuits involve the safety-related functions of a machine that minimize the level of risk of harm. These safety-related functions can prevent initiation, or they can stop or remove a hazard. The failure of a safety-related function or its associated safety circuit usually results in an increased risk of harm.

The integrity of a safety circuit depends on several factors, including fault tolerance, risk reduction, reliable and well-tried components, well-tried safety principles, and other design considerations.

Depending on the level of risk associated with the machine or its operation, an appropriate level of safety circuit performance (i.e., integrity) must be incorporated into the design. The standards that details safety performance levels is ISO 13849-1 (EN954-1) Safety-Related Parts of a Control System.

Safety Circuit Integrity Levels

Safety circuits in International and European standards have been segmented into categories, depending on their ability to maintain their integrity in the event of a failure. The most recognized standard that details safety circuit integrity levels is ISO 13849-1 (EN954-1), which establishes five levels: Categories B, 1, 2, 3, and the most stringent, Category 4.

If the requirements described by ISO 13849-1 (EN954-1) are to be implemented, a risk assessment must first be performed to determine the appropriate category, in order to ensure that the expected risk reduction is achieved. This risk assessment must also take into account national regulations, such as European "C" level standards, to ensure that the minimum level of performance that has been mandated is complied with.

Fault Exclusion

An important concept within the category requirements of ISO 13849-1 (EN954-1) is the “probability of the occurrence of the failure,” which can be decreased using a technique termed “fault exclusion.” The rationale (underlying reasons) assumes that the possibility of certain well-defined failure(s) can be reduced to a point where the resulting fault(s) can be, for the most part, disregarded—that is, “excluded.”

Fault exclusion is a tool a designer can use during the development of the safety-related part of the control system and the risk assessment process. Fault exclusion allows the designer to design out the possibility of various failures and justify it through the risk assessment process to meet the intent requirements of Category 2, 3 or 4. See ISO 13849-1/-2 for further information.

4.5.5.2 Generic SSI & MSSl Connection

To fully understand category requirements, refer to standard ISO 13849-1 (EN954-1). The following is general in nature and is intended to provide only basic guidance. Each guarding application has its unique set of requirements; it is the user's responsibility to ensure that all local, state, and national laws, rules, codes, and regulations are satisfied.

In addition to the use of well-tried, tested, and robust components, and generally accepted principles (including fault exclusion), the safety function depends on the use of safety-rated devices. These devices are specially designed to reduce the probability of failing to an unsafe condition, and typically are third-party certified to a recognized safety standard.

Category 2

To meet the requirements of a Category 2 application, any device connected to the SSI and MSSl inputs must meet certain criteria. For example, a “type 2” light screen (curtain) that meets IEC 61496-1/-2 is a device that meets Category 2 requirements.

A Category 2 safety function must be tested/checked at suitable intervals, the frequency determined by the application's risk assessment. It should be noted that a single fault may cause the loss of the safety function.

The principle of fault exclusion must be incorporated into the design and installation to either eliminate, or reduce to an acceptable (minimal) level of risk, the possibility of undetected faults or failures that can result in the loss of the safety function.

For generic Category 2 typical Interfacing connections, refer to [figure 26 on page 56](#) and [figure 27 on page 56](#).

Category 3

To meet the requirements of a Category 3 application, any device connected to the SSI and MSSl inputs must meet certain criteria. For example, a “type 3” laser area scanner that meets IEC 61496-1/-3 is a device that meets Category 3 requirements.

In a Category 3 safety application, a single fault must not cause the loss of the safety function. This is usually accomplished by using redundant safety inputs or outputs from the safety-rated device. Faults should be detected whenever reasonably practicable, although a short circuit between input channels or safety outputs may not be detected. It should be noted that an accumulation of faults may cause the loss of the safety function.

The principle of fault exclusion must be incorporated into the design and installation to either eliminate, or reduce to an acceptable (minimal) level of risk, the possibility of undetected faults or catastrophic failures that could result in the loss of the safety function.

For generic Category 3 typical Interfacing connections, refer to [figure 28 on page 56](#) and [figure 29 on page 56](#).

Category 4

To ensure a Category 4 application, any device connected to the SSI and MSSl inputs must meet certain criteria. For example, a “Type 4” safety light screen that meets IEC 61496-1/-2 is a device that meets Category 4 requirements.

In a Category 4 application, a single fault must not cause the loss of the safety function. The fault must be detected at or before the next demand of the safety function, and an accumulation of faults also must not cause the loss of the safety function.

This is usually accomplished by the use of redundant safety inputs or outputs from the safety-rated device that are monitored to detect certain faults. These faults include:

- Increased response time
- Prevention of one or more safety outputs (OSSDs) going to the OFF-state
- A short circuit between channels
- ☛ *Solid-state safety outputs, such as those from EZ-SCREEN Type 4 safety light screens, typically achieve this level of fault tolerance by self-monitoring a pulsing of the outputs. Safety devices with hard-contact or relay outputs must be connected in a “4-wire” method as shown in [figure 31 on page 56](#).*

The principle of fault exclusion must be incorporated into the design and installation to either eliminate, or reduce to an acceptable (minimal) level of risk, the possibility of catastrophic failures/faults that could result in the loss of the safety function.

For generic Category 4 typical Interfacing connections, refer to [figure 30 on page 56](#), [figure 31 on page 56](#) and [figure 32 on page 57](#).

4.5.5.3 SSI Emergency Stop (E-STOP) Switch Connection

Safety Circuit Integrity Levels and Emergency Stop functions

! WARNINGS!**EMERGENCY STOP FUNCTIONS**

DO NOT CONNECT ANY DEVICE TO THE MSS I INPUT THAT IS USED FOR AN EMERGENCY STOP FUNCTION. NEVER MUTE OR BYPASS ANY EMERGENCY STOP DEVICE (E.G., A BUTTON OR ROPE PULL). IEC/EN 60204-1 REQUIRES THAT THE EMERGENCY STOP FUNCTION REMAINS ACTIVE AT ALL TIMES.

MUTING OR BYPASSING THE SAFETY OUTPUTS RENDERS THE EMERGENCY STOP FUNCTION INEFFECTIVE.

RESET ROUTINE REQUIRED

INTERNATIONAL STANDARDS REQUIRE THAT A RESET ROUTINE BE PERFORMED AFTER RETURNING THE E-STOP SWITCH TO ITS CLOSED-CONTACT POSITION (WHEN ARMING THE E-STOP SWITCH). WHEN AUTOMATIC RESET IS USED, AN ALTERNATE MEANS MUST BE ESTABLISHED TO REQUIRE A RESET ROUTINE, AFTER THE E-STOP SWITCH IS ARMED. ALLOWING THE MACHINE TO RESTART AS SOON AS THE E-STOP SWITCH IS ARMED CREATES AN UNSAFE CONDITION WHICH COULD RESULT IN SERIOUS INJURY OR DEATH.

! WARNING!**MULTIPLE E-STOP SWITCHES**

- CONTACTS OF THE CORRESPONDING POLE OF EACH SWITCH MUST BE CONNECTED TOGETHER IN SERIES. NEVER CONNECT THE CONTACTS OF MULTIPLE EMERGENCY STOP SWITCHES IN PARALLEL TO ONE MODULE. SUCH A PARALLEL CONNECTION DEFEATS THE SWITCH CONTACT MONITORING ABILITY OF THE MODULE AND CREATES AN UNSAFE CONDITION WHICH COULD RESULT IN SERIOUS INJURY OR DEATH
- EACH SWITCH MUST BE INDIVIDUALLY ACTUATED (ENGAGED), THEN RE-ARMED AND THE MODULE RESET. THIS ALLOWS THE CONTROLLER TO CHECK EACH SWITCH AND ITS WIRING TO DETECT FAULTS. FAILURE TO TEST EACH SWITCH INDIVIDUALLY IN THIS MANNER COULD RESULT IN UNDETECTED FAULTS AND CREATE AN UNSAFE CONDITION WHICH COULD RESULT IN SERIOUS INJURY OR DEATH. THIS CHECK MUST BE PERFORMED DURING PERIODIC CHECK-OUTS (SEE block 6.1.2 on page 39)

Emergency Stop Push Button Switches

The E-stop switch must provide one or two contacts for safety which are closed when the switch is armed as shown in [figure 33 on page 57](#), [figure 34 on page 57](#) and [figure 35 on page 57](#). Once activated, the E-stop switch must open all its safety-rated contacts, and must require a deliberate action (such as twisting, pulling, or unlocking) to return to the closed-contact, armed position. The switch should be a "positive-opening" (or direct-opening) type, as described by IEC 60947-5-1. A mechanical force applied to such a button (or switch) is transmitted directly to the contacts, forcing them open. This ensures that the switch contacts open whenever the switch is activated.

Standards IEC/EN 60204-1 and ISO 13850 specify additional emergency stop switch device requirements, including the following:

- Emergency Stop push buttons shall be located at each operator control station and at other operating stations where emergency shutdown is required
- Stop and Emergency Stop push buttons shall be continuously operable and readily accessible from all control and operating stations where located. Do not connect E-stop buttons to the MSS I
- Actuators of Emergency Stop devices shall be coloured Red. The background immediately around the device actuator shall be coloured Yellow. The actuator of a push-button-operated device shall be of the palm or mushroom-head type
- The Emergency Stop actuator shall be a self-latching type

 Some applications may have additional requirements. The user must comply with all relevant regulations.

As part of the required risk assessment for the machine, IEC/EN 60204-1 states that the safety performance (integrity) must reduce the risk from identified hazards as determined by the risk assessment. See [block 4.5.5.1 on page 26](#) and [block 4.5.5.2 on page 27](#) for guidance if the requirements as described by ISO 13849-1 (EN954-1) are to be implemented.

In addition to the requirements stated above, the design and the installation of the emergency stop device (e.g., switch, button, or rope-pull) must be such that the possibility of a catastrophic failure of the device resulting in the loss of the safety function must be excluded (designed out). As per requirement in ISO 13849-2, electromechanical devices that have contacts designed in accordance with IEC 60947-5-1 Annex K and that are installed as per manufacturer's instructions are expected to open when the emergency stop device is actuated.

Category 2

A single-channel emergency stop application typically provides a category 2 level of circuit performance, because a short circuit could cause the loss of the safety function. The principle of fault exclusion must be incorporated into the design and installation to either eliminate, or reduce to an acceptable (minimal) level of risk, the possibility of undetected faults or failures that can result in the loss of the safety function. For an SSI E-stop Category 2 typical interface connection, refer to [figure 33 on page 57](#).

Category 3

A dual-channel connection switching +24 VDC is typically a Category 3 application, because a single failure does not result in a loss of safety. Loss of the switching action in one channel is detected by the actuation of the E-stop button, the opening of the second channel, and the monitoring function of the SSI inputs. However, a short circuit between input channels or safety outputs may not be detected. It should be noted that an accumulation of faults may cause the loss of the safety function (refer to [figure 38 on page 58](#)).

The principle of fault exclusion must be incorporated into the design and installation to either eliminate, or reduce to an acceptable (minimal) level of risk, the possibility of undetected faults or catastrophic failures that could result in the loss of the safety function. For an SSI E-stop Category 3 typical interface connection, refer to [figure 34 on page 57](#).

Category 4

The self-monitoring SSI inputs can be interfaced to achieve a category 4 application. The principle of fault exclusion must be incorporated into the design and installation to either eliminate, or reduce to an acceptable (minimal) level of risk, the possibility of catastrophic failures or faults that could result in the loss of the safety function. For an SSI E-stop Category 4 typical interface connection, refer to [figure 35 on page 57](#).

4.5.5.4 SSI/MSSI Interlocked Guard or Safety Gate Connection



WARNING!

FIXED GUARDING

IT MUST NOT BE POSSIBLE FOR PERSONNEL TO REACH ANY HAZARD POINT THROUGH AN OPENED GUARD (OR ANY OPENING) BEFORE HAZARDOUS MACHINE MOTION HAS COMPLETELY STOPPED AS STATED IN STANDARD ISO 13852.

The SSI (or MSSI) may be used to monitor interlock safety gates or guards.

Requirements vary widely for the level of control reliability or safety category per ISO 13849-1 (EN954-1) in the application of interlocked guards. While *Banner Engineering* always recommends the highest level of safety in any application, it is the responsibility of the User to safely install, operate and maintain each safety system and comply with all relevant laws and regulations.

The safety performance (integrity) must reduce the risk from identified hazards as determined by the machine's risk assessment. See [block 4.5.5.1 on page 26](#) and [block 4.5.5.2 on page 27](#) for guidance if the requirements as described by ISO 13849-1 (EN954-1) are to be implemented.

In addition to the requirements stated in this section, the design and installation of the interlocking device should comply with ISO 14119.

Safety Interlocking Switch Requirements

See [Safety Interlocking Switch Requirements on page 5](#).

Positive-opening Safety Interlocking Switches Requirements

See [Positive-opening Safety Interlocking Switches Requirements on page 5](#).

Monitoring Series-Connected Safety Interlocking Switches

When monitoring two individually mounted safety switches (as shown in [figure 38 on page 58](#)), a faulty switch is detected if it fails to switch as the guard opens. In this case, the DIN Muting Module de-energizes its safety outputs (OSSDs) and disable its reset function until the input requirements are met (i.e., the faulty switch is replaced). However, when a series of safety interlocking switches is monitored by a single DIN Muting Module, the failure of one switch in the system may be masked or not detected at all (refer to [figure 36 on page 57](#) and [figure 37 on page 58](#)).

Series-connected interlock switch circuits may not meet ISO13849 (EN954-1) Safety Category 4 requirements because of the potential of an inappropriate reset or a potential loss of the safety stop signal. This is due to the typical inability to fault exclude the failure of the safety interlock switch. A multiple connection of this type should not be used in applications where loss of the safety stop signal or an inappropriate reset can lead potentially to serious injury or death. The following two scenarios assume two positive-opening safety switches on each guard:

Masking of a Failure If a guard is opened but a switch fails to open, the redundant safety switch opens and causes the DIN Muting Module to de-energize its outputs. If the faulty guard is then closed, both DIN Muting Module input channels also close, but because one channel did not open, the DIN Muting Module does not reset. However, if the faulty switch is not replaced and a second good guard is cycled, opening and then closing both of the DIN Muting Module's input channels, the DIN Muting Module considers the failure to be corrected. With the input requirements apparently satisfied, the DIN Muting Module allows a reset. This system is no longer redundant and, if the second switch fails, may result in an unsafe condition (i.e., the accumulation of faults results in the loss of the safety function).

Non Detection of a Failure If a good guard is opened, the DIN Muting Module de-energizes its outputs (a normal response). But, if a faulty guard is then opened and closed before the good guard is re-closed, the failure on the faulty guard is not detected. This system also is no longer redundant and may result in a loss of safety if the second safety switch fails to switch when needed.

The systems in either scenario do not inherently comply with the safety standard requirements of detecting single faults and preventing the next cycle. In multiple-guard systems using series-connected safety switches, it is important to periodically check the functional integrity of each interlocked guard individually. **Operators, maintenance personnel, and others associated with the operation of the machine must be trained to recognize such failures and be instructed to correct them immediately.**

Monitoring Procedure

- 1) Open and close each Safeguarding Device(s) separately while verifying that DIN Muting Module outputs operate correctly throughout check procedure.
- 2) If necessary, after closing each Safeguarding Device(s), select a Manual Reset.

☞ *If a contact set fails, the DIN Muting Module does not enable its Reset function. If the DIN Muting Module does not reset, a switch may have failed; that switch must be immediately replaced.*

This check must be performed and all faults must be cleared, at a minimum, during periodic check-outs. If the application can not exclude these types of failures and such a failure could result in serious injury or death, then the series connection of safety switches must not be used.

Category 2

A single-channel interlocked guard application typically provides a Category 2 level of circuit performance, because a short circuit could cause the loss of the safety function. The principle of fault exclusion must be incorporated into the design and installation to either eliminate, or reduce to an acceptable (minimal) level of risk, the possibility of undetected faults or failures that can result in the loss of the safety function.

For an SSI/MSSI Interlocked Guard or Safety Gate Category 2 typical interface connection, refer to [figure 36 on page 57](#).

Category 3

A dual-channel connection switching +24 VDC is typically a Category 3 application, because a single failure does not result in a loss of safety. Loss of the switching action in one channel is detected by the actuation of opening and closing the guard, allowing the monitoring function of the MSSI or SSI inputs to detect the discrepancy between the channels. However, a short circuit between input channels or safety outputs may not be detected. It should be noted that an accumulation of faults may cause the loss of the safety function.

The principle of fault exclusion must be incorporated into the design and installation to either eliminate, or reduce to an acceptable (minimal) level of risk, the possibility of undetected faults or catastrophic failures that could result in the loss of the safety function.

For an SSI/MSSI Interlocked Guard or Safety Gate Category 3 typical interface connection, refer to [figure 37 on page 58](#).

Category 4

The self-monitoring MSSI or SSI inputs can be interfaced to achieve a Category 4 application. The principle of fault exclusion must be incorporated into the design and installation to either eliminate, or reduce to an acceptable (minimal) level of risk, the possibility of catastrophic failures/faults that could result in the loss of the safety function.

For an SSI/MSSI Interlocked Guard or Safety Gate Category 4 typical interface connection, refer to [figure 38 on page 58](#).

4.5.5.5 SSI Supplementary Safety System Connection

A variety of safety systems can be interfaced with the MSSI and the SSI. Each safety application has a unique set of application requirements; the User is responsible to ensure proper installation, and use, and that all relevant standards and regulations are complied with. [figure 25 on page 55](#) is a generic example of the flexibility of the SSI.

Entry/Exit Application with Multiple Beam Safety System (muted) & Safety Mat System

This application is widely used in a variety of situations, including manufacturing cell, robotic cells, palletizers, and de-stackers (see [appendix A3 on page 61](#) for more information). One of the many requirements of this muting application is that it must not be possible for personnel to walk in front of, behind, or next to the muted object (for example: the carrier basket) without being detected and stopping the hazardous motion.

[Figure 25 on Page 55](#) shows how supplementary guarding (such as a safety mat system or horizontal safety light screen) can be interfaced to prevent personnel from entering the hazardous area during a mute condition.

4.6 INITIAL CONNECTION & CHECKOUT

4.6.1 GENERAL

Model MMD-TA-11B provides two normally open safety relay output contacts (13-14 and 23-24) to connect external MPCE1 and MPCE2 (see [figure 15 on page 53](#) and [figure 16 on page 53](#)).

Model MMD-TA-12B provides two PNP solid-state safety outputs, OSSD1 and OSSD2 (Y5-Y6 and Y7-Y8) see [figure 12 on page 50](#), [figure 13 on page 51](#), and [figure 14 on page 52](#).

For monitoring external devices (both models), normally closed contacts of these devices must be connected to EDM 1 (Y1-Y2) and EDM 2 (Y3-Y4).

Before proceeding, ensure that power has been removed from machine or ensure that power is not available to the machine controls or actuators, and ensure that the machine control (MPCEs) are not connected to or controlled by the OSSD or relay safety outputs at this time. Permanent connections are made after Module initial checkout (see [block 4.7 on page 33](#)).

The Initial Checkout must be performed by a [Qualified Person as specified in block 1.9.2 on Page 3](#). It must be performed only after configuring the Module and after properly installing and configuring the safety systems connected to its MSSl and the SSl inputs (as per [Chapter 4 on Page 21](#)).

The Initial Checkout should be carried out for the following events:

- To ensure proper installation when the System is first installed
- To ensure proper System functionality whenever any maintenance or modification is performed on the System or on the machinery being guarded by the System (see [block 6.1.2 on page 39](#) for a schedule of required check-outs)

For the initial checkout, the Muting Module and associated safety systems must be checked without power being available to the guarded machine. Final interface connections to the guarded machine cannot take place until these systems have been checked out.

4.6.2 Preparation

Verify the following:

- 1) That power has been removed from machine or ensure that power is not available to machine controls or actuators.
- 2) That machine control circuit is not connected to the OSSD outputs at this time (permanent connections are made following this initial checkout), and that the OSSD leads are isolated (i.e. not shorted together, not shorted to power or ground).
- 3) That EDM has been configured for No Monitoring (SW4 = OFF or 2 CH) and EDM 1 (Y1-Y2) and EDM 2 (Y3-Y4) are jumpered.
- 4) That other than EDM and Mute Enable, check proper DIN Muting Module DIP switch configuration for specified application.
- 5) That all input connections have been made per appropriate sections for Mute Input Devices (M1-M4), SSl, MSSl, Manual Reset Switch, Mute Lamp, AUX Output, and Override Input.

This allows the DIN Muting Module and the associated safety systems to be checked out stand alone before permanent connection is made to the safeguarded machine.

4.6.3 Initial Procedure

☛ All wiring must comply with local wiring codes.

- 1) Connect DC power to system at terminals A1(+24VDC) and A2 (0 VDC) (see [block 4.4 on page 23](#) and [table 5 on page 23](#)).
- 2) Leaving power to safeguarded machine OFF, power up DIN Muting Module and safety systems connected to MSSl and SSl inputs.
- 3) Perform system checkout procedures for external safety systems connected to MSSl and SSl inputs as described in appropriate manuals.



Do not proceed further until all checkout procedures are completed successfully and all problems have been corrected.

- 4) Verify that external safety systems are providing a Green/GO signal to MSSl and SSl inputs (that is, *Banner* OSSD sourcing signal or a closed contact connected to the Signal pin of each interface).
- 5) Verify that Channel indicators A and B on DIN Muting Module show steady green.



☛ If the SSl is not used, terminals X5-X6 and X7-X8 must be jumpered. Do not short Channel A to Channel B see [block 4.5.5 on page 26](#).

Auto Reset Configuration

- 6) Verify that status LED shows steady green, indicating that OSSD outputs are ON, and that a  appears on Diagnostic Display. If not, or if red status indicator begins to flash  at any

time, refer to [block 6.2.1 on page 45](#) for troubleshooting information.

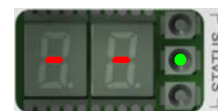

Manual Reset Configuration

- 7) Verify that status LED is flashing yellow to indicate that a reset is being requested, and that a  appears on the Diagnostic Display.

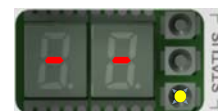

If not, or if the status indicator shows flashing red  at any time, refer to [block 6.2.1 on page 45](#) for troubleshooting information.

- 8) Perform a manual reset as detailed in [block 4.5.1 on page 25](#).

- 9) Verify that status indicator shows steady green .

☛ OSSD Outputs should already be ON at this stage.

- 10) Cycle MSSSI and SSI individually and ensure that status indicator LEDs show green OFF with red and yellow ON and that a Reset is possible after Interface is closed.



If any of these checks fail, do not attempt to use the system until the reason for the failure(s) is identified and corrected.

☛ If the Muting function is not used, proceed to [block 4.7 on page 33](#).

- 11) Verify (if possible) that power has been removed or is otherwise not available to machine controls responsible for hazardous motion.

During the initial checkout procedure of the Muting feature, if possible, verify that the power has been removed or is otherwise not available to the machine actuators responsible for hazardous motion. At all times ensure that personnel are not exposed to any hazard.

- 12) Mute system by blocking (or activating) both mute devices (typically M1- M2) simultaneously (within 3 s).
 13) If used, verify that Mute indicator(s) show steady green. If not, check indicator(s) and wiring. Check also Diagnostic Display for error codes.

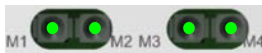

- 14) Generate a **stop** command from Safeguarding Device(s) connected to MSSSI (for example, interrupt defined area of a safety light screen). Verify that MSSSI Channel A and B green Status indicators are OFF.



☛ If the 30 or 60-second Backdoor Timer feature has been selected, the Diagnostic Display begins to count down in seconds. If the 30-minute Backdoor Timer feature is selected, the timer countdown is in minutes. If Backdoor Timer is OFF (infinite), a flashing dash appears on the display.



- 15) Clear Stop command (before Backdoor Timer expires) and verify that MSSSI Channel A and B indicators come ON. Clear (deactivate) mute devices before Backdoor Timer expires and verify Mute indicator goes OFF. Green status indicator should remain ON.



- 16) Verify that it is not possible for a single individual to initiate a mute condition by triggering mute devices (for example, by blocking both photoelectric beams or actuating both switches) and being able to pass through safeguard without being detected and without issuing a stop command to machine.

Do not expose any individual to hazard while attempting to mute the system.

- 17) Verify that it is not possible for personnel to pass in front of, behind, or next to the muted object without being detected and without issuing a stop command to machine.
 18) If one-way (directional) muting has been selected, verify that system can not be muted by blocking (or activating) M3-M4 before M1-M2.

Do not expose any individual to hazard while attempting to mute the system.

If any of these checks fail, do not attempt to use the system until the reason for the failure(s) is identified and corrected.

4.7 PERMANENT ELECTRICAL CONNECTION

WARNING!

HIGH VOLTAGE SHOCK HAZARD FOR MODEL MMD-TA-11B

ALWAYS DISCONNECT ALL POWER FROM THE DIN MUTING MODULE AND THE GUARDED MACHINE BEFORE MAKING ANY CONNECTIONS OR REPLACING ANY COMPONENT. USE EXTREME CAUTION TO AVOID ELECTRICAL SHOCK AT ALL TIMES. SERIOUS BODILY INJURY OR DEATH COULD RESULT.

WARNING!

SHOCK HAZARD FOR MODEL MMD-TA-12B

ALWAYS DISCONNECT POWER FROM THE DIN MUTING MODULE, SAFETY SYSTEM AND THE SAFEGUARDED MACHINE BEFORE MAKING ANY CONNECTIONS OR REPLACING ANY COMPONENT. USE EXTREME CAUTION TO AVOID ELECTRICAL SHOCK AT ALL TIMES. SERIOUS BODILY INJURY OR DEATH COULD RESULT.

WARNING!

PROPER WIRING

THE GENERALIZED WIRING CONFIGURATION SHOWN IN [figure 12 on page 50](#), [figure 13 on page 51](#), [figure 14 on page 52](#), [figure 15 on page 53](#), AND [figure 16 on page 53](#) ARE PROVIDED ONLY TO ILLUSTRATE THE IMPORTANCE OF PROPER INSTALLATION. THE PROPER WIRING OF THE SAFETY SYSTEM TO ANY PARTICULAR MACHINE IS THE SOLE RESPONSIBILITY OF THE INSTALLER AND END USER.

 *The Supply Power, External Reset Switch, and other inputs (as required by each application) should have been previously connected at this point.*

The following permanent connections should now be made:

- ME
- EDM
- MPCE
- OSSD outputs
- FSD Interfacing

4.7.1 Mute Enable (ME) Connection

The DIN Muting Module provides a Mute Enable (ME, X13-X14)(see [block 1.11.8 on page 7](#)). ME gives the user the ability to frame or create a window of opportunity when a mute can occur. When configured, the ME input is a contact that must be closed before the Safeguarding Device(s) can be muted. After the Safeguarding Device(s) is muted, opening of the ME input has no effect, but it must be re-closed before the Safeguarding Device(s) can be muted again.

To connect a device (sensor or PLC output) with a solid state output, see optional connection in [figure 39 on page 58](#).

 *If ME is not used, leave the connection open.*

4.7.2 EXTERNAL DEVICE MONITORING (EDM) Connection

WARNINGS!

EDM CONFIGURATION

IF THE APPLICATION DOES NOT REQUIRE THIS FUNCTION, THE TERMINAL Y1 OF EDM 1 MUST BE JUMPED TO Y3 OF EDM 2 (SEE [block 4.7.2 on page 33](#)). IT IS THE USER'S RESPONSIBILITY TO ENSURE THAT THIS DOES NOT CREATE A HAZARDOUS SITUATION.

NOTICE REGARDING EDM CONNECTION

IT IS STRONGLY RECOMMENDED THAT ONE NORMALLY CLOSED (NC), FORCED-GUIDED, MONITORING CONTACT OF EACH MPCE OR EXTERNAL DEVICE BE WIRED IN ORDER TO MONITOR THE STATE OF THE MPCEs (AS SHOWN IN [figure 12](#), [figure 13](#), [figure 14](#), [figure 15](#) & [figure 16 on page 53](#)). IF THIS IS DONE, PROPER OPERATION OF THE MPCEs IS VERIFIED. MPCE MONITORING CONTACTS MUST BE USED IN ORDER TO DETECT IMPROPER FUNCTIONING OF THE MPCEs.

The DIN Muting Module provides connection terminals for the EDM input (EDM 1—Y1–Y2 and EDM 2—Y3–Y4).

- 1) Connect EDM in one of three configurations as follows:

One Channel Monitoring

SW4 Bank A & Bank B = ON or 1CH

(see [figure 14](#) and [figure 16 on page 53](#))

 *EDM 2 input must be left open.*

Two-Channel Monitoring

SW4 Bank A & Bank B = OFF or 2 CH

(see [figure 12](#), [figure 13](#) and [figure 15 on page 53](#))

No Monitoring

SW4 Bank A & Bank B = OFF or 2 CH

 *Terminal Y1 of EDM 1 must be jumpered to Y3 of EDM 2*

After the initial checkout has been successfully completed, the EDM configuration that disabled the monitoring function must be properly re-configured. The External Device Monitoring inputs then must be properly connected to the closed monitoring contacts of the MPCEs (see [block 1.11.6 on page 6](#)). Refer to the **NOTICE** Regarding MPCE Monitoring Connection and [figure 12](#), [figure 13](#), [figure 14](#), [figure 15](#) and [figure 16 on page 53](#).

4.7.3 OSSD Output Connections

WARNING!

OSSD INTERFACING

TO ENSURE PROPER OPERATION, THE DIN MUTING MODULE OUTPUT PARAMETERS AND MACHINE INPUT PARAMETERS MUST BE CONSIDERED WHEN INTERFACING THE DIN MUTING MODULE SOLID-STATE OSSD OUTPUTS TO THE MACHINE INPUTS. MACHINE CONTROL CIRCUITRY MUST BE DESIGNED SO THAT:

- THE MAXIMUM CABLE RESISTANCE VALUE BETWEEN THE DIN MUTING MODULE SOLID-STATE SAFETY OUTPUTS AND THE MACHINE INPUTS IS NOT EXCEEDED
- THE DIN MUTING MODULE SOLID-STATE SAFETY OUTPUT MAXIMUM OFF-STATE VOLTAGE DOES NOT RESULT IN AN ON CONDITION
- THE DIN MUTING MODULE SOLID-STATE SAFETY OUTPUT MAXIMUM LEAKAGE CURRENT, DUE TO THE LOSS OF 0 V, DOES NOT RESULT IN AN ON CONDITION

Failure to properly interface the OSSD outputs to the guarded machine could result in serious bodily injury or death.

 Before making OSSD connections and interfacing of the DIN Muting Module to the machine, refer to the Output Specifications (table 2 on page 17).

- 1) Connect OSSD outputs such that machine's safety related control system interrupts circuit or power to MPCE, resulting in a **non-hazardous** condition.

This applies equally to the safety relays of the model **MMD-TA-11B** and the solid-state output of the model **MMD-TA-12B**.

FSDs typically accomplish this when OSSDs go to an OFF state (see figure 12 on page 50).

4.7.4 FSD Interfacing Connections

See block 1.11.16 on page 9.

4.8 COMMISSIONING CHECKOUT

Perform this checkout procedure as part of Safeguarding Device(s) System installation (after the System has been interfaced to the safeguarded machine as described in [block 4.6 on page 31](#) and [block 4.7 on page 33](#)), or whenever changes are made to the System (either a new configuration of the DIN Muting Module, devices connected to it, or changes to the machine). A [Qualified Person as specified in block 1.9.2 on Page 3](#) must perform this procedure. Checkout results should be recorded and kept on or near the safeguarded machine.

4.8.1 Preparation

Prepare the DIN Muting Module for this checkout as follows:

- 1) Referring to [figure 7 on page 22](#) and [table 4 on page 22](#) verify configuration is the same as for required machine operation. □

4.8.2 Safeguarding Device(s) Checkout

- 1) Examine safeguarded machine to verify that it is of a type and design compatible with Safeguarding Device(s) system that has been installed (see [block 1.12 on page 10](#)). □
- 2) Verify system(s) checkout procedures for external safety systems connected to MSSI and SSI inputs as described by appropriate manuals. Do not proceed until all checkout procedures are completed successfully and all problems have been corrected. □
- 3) Verify that:
 - Access to any dangerous parts of safeguarded machine is not possible from any direction not protected by Safeguarding Device(s) system, fixed guarding, or supplementary Safeguarding Device(s)
 - Supplementary Safeguarding Device(s) and fixed guarding, as described by appropriate safety standards, are in place and functioning correctly □
- 4) Verify that Reset Switch is mounted outside safeguarded area, out of reach of anyone inside safeguarded area, and that means of preventing inadvertent use is in place. □
- 5) Examine electrical wiring connections between the Module's OSSD outputs and safeguarded machine's control elements to verify that wiring meets requirements stated in [block 4.7 on page 33](#). □
- 6) Ensure that power to safeguarded machine is OFF. □
- 7) Apply power to DIN Muting Module. □
- 8) Verify that external safety systems are providing a green/Go signal to MSSI and SSI inputs and that Green MSSI and SSI indicators (two pairs of LEDs located near each terminal) are ON. □



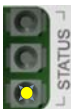

When configured for a Manual Reset, yellow status indicator is

flashing.  □

- 9) Perform a Manual Reset as detailed in [block 4.5.1.1 on page 25](#).

Verify that green status indicator is ON steady.  □

 A Red flashing status indicator signifies a lockout condition. Refer to [block 6.2.1 on page 45](#) for information.  □

- 10) In a non-muted condition, generate a stop command from safeguarding device connected to MSSI (for example, interrupt defined area of a safety light screen). □
- 11) Verify that MSSI Channels A and B LEDs are OFF and status indicator LEDs show green OFF with red and yellow ON. □



- 12) In order, reset safeguard and then Module (in Manual Reset). □
- 13) Generate a stop command from safeguarding device connected to SSI (for example, actuate E-stop button). □
- 14) Verify that SSI Channels A and B go OFF and status indicator LEDs show green OFF with red and yellow ON. □



- 15) In order, reset safeguard and then Module (in Manual Reset). □
- 16) Apply power to guarded machine and verify that machine does not start up. □
- 17) Generate a stop command from safeguarding device connected to SSI and MSSI in a non-muted condition. □
- 18) Verify that it is not possible for the guarded machine to be put into motion while either stop commands are present. □
- 19) In order, reset safeguard and then Module (in Manual Reset). □
- 20) Initiate machine motion of guarded machine and while it is moving, as in [Step 17](#)) above, generate a stop command from each safeguarding device. □

 Do not attempt to insert anything into dangerous parts of machine.

- 21) Upon issuing stop command, check that dangerous parts of machine come to a stop with no apparent delay. □
- 22) Upon reset of safeguard and Module, verify that machine does not automatically restart, and that initiation devices must be engaged to restart machine. □
- 23) Remove electrical power from Module. □
- 24) Check all OSSD outputs immediately turn OFF and should not be capable of turning ON until power is re-applied and a reset is accomplished. □
- 25) Test machine stopping response time, using an instrument designed for that purpose, to verify that it is same or less than overall system response time specified by machine manufacturer. (Banner's Applications Engineering Department may be able to recommend a suitable instrument.) □

Do not continue operation until the entire checkout procedure is complete and all problems are corrected.

4.8.3 Muting Checkout

- 1) Verify that DIN Muting Module has been Reset and Status indicator shows steady green.



If Status indicator is flashing yellow (indicating DIN Muting Module is waiting for a Reset of a latched condition), perform a Manual Reset as detailed in [block 4.5.1.1 on page 25](#).



If at any time red status indicator begins to flash, a lockout condition exists. Refer to [block 6.2.1.1 on page 45](#) to determine cause of lockout.



At all times ensure that personnel are not exposed to any hazard.

- 2) Mute system by blocking (or activating) both mute devices (typically M1- M2) simultaneously (within 3 s).
- 3) Verify that Mute indicator(s) show steady green. If not, check indicator(s) and wiring.



Check also Diagnostic Display for error codes.

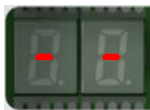

- 4) Generate a **stop** command from Safeguarding Device(s) connected to MSSl. Verify that MSSl Channel A and B are OFF and green Status indicator is ON.



If the 30 or 60-second Backdoor Timer feature has been selected, the Diagnostic Display begins to count down; otherwise a flashing dash appears on the display.



- 5) Clear or Reset Safeguarding Device(s) (before Backdoor Timer expires) and verify MSSl channel indicators are steady green.



Clear (deactivate) Mute devices before Backdoor Timer expires and verify Mute indicator(s) go OFF.



Status indicator should remain steady green.



- 6) Verify that it is not possible for a single individual to initiate a mute condition by triggering Mute devices (for example, by blocking both photoelectric beams or actuating both switches) and access hazard without being detected and issuing a stop command to machine (where status indicator LEDs show green

OFF with red and yellow ON, and a Reset of latch condition is required).



At all times ensure that personnel are not exposed to any hazard.

- 7) Verify that it is not possible for personnel to pass in front of, behind, or next to the muted object without being detected and without issuing a stop command to machine.
- 8) If one-way (directional) muting has been selected, verify that system can not be muted by blocking (or activating) M3-M4 before M1-M2.

WARNING!

DO NOT ATTEMPT TO USE THE SYSTEM

IF ANY OF THESE CHECKS FAIL, DO NOT ATTEMPT TO USE THE SYSTEM UNTIL THE REASON FOR THE FAILURE(S) IS IDENTIFIED AND CORRECTED.

5 OPERATING

WARNINGS!

BEFORE OPERATING THE EQUIPMENT

READ THE SAFETY INFORMATION CONTAINED IN [Chapter 1 on Page 1](#).

VERIFY PROPER OPERATION

THE DIN MUTING MODULE AND SAFETY SYSTEMS CAN ONLY DO THE JOB FOR WHICH THEY WERE DESIGNED IF THEY AND THE MACHINE THEY SAFEGUARD ARE OPERATING PROPERLY, BOTH SEPARATELY AND TOGETHER. IT IS THE USER'S RESPONSIBILITY THEREFORE TO VERIFY PROPER OPERATION ON A REGULAR BASIS AS INSTRUCTED IN [block 6.1.2 on page 39](#). IF THE DIN MUTING MODULE, SAFETY SYSTEMS, AND THE SAFEGUARDED MACHINE DO NOT PERFORM EXACTLY AS OUTLINED IN THE CHECKOUT PROCEDURES, THE CAUSE OF THE PROBLEM MUST BE FOUND AND CORRECTED BEFORE THE SYSTEM IS PUT BACK INTO SERVICE. FAILURE TO CORRECT SUCH PROBLEMS CAN RESULT IN SERIOUS BODILY INJURY OR DEATH.

POWER FAILURES

POWER FAILURES OR OTHER MODULE LOCKOUT CONDITIONS SHOULD ALWAYS BE INVESTIGATED IMMEDIATELY BY A [Qualified Person](#) as specified in [block 1.9 on Page 3](#). A LOCKOUT IS A DEFINITE INDICATION OF A PROBLEM AND SHOULD BE INVESTIGATED AT ONCE. ATTEMPTS TO CONTINUE TO OPERATE MACHINERY BY BY-PASSING THE MODULE ARE DANGEROUS AND COULD RESULT IN SERIOUS BODILY INJURY OR DEATH.

5.1 EQUIPMENT INDICATION & CONTROLS

5.1.1 Indications

A breakdown of the DIN Muting Module three status LEDs and diagnostic displays on the front, are shown in [figure 9 on page 37](#) and [table 7 on page 37](#).

 See also [figure 2 on page 12](#) for an overview of indications.

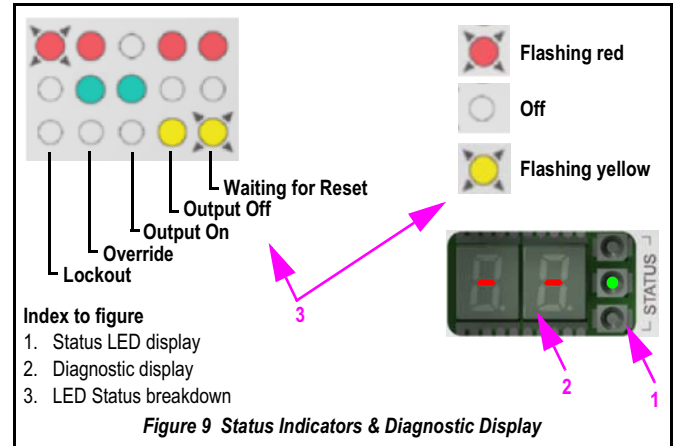

















Table 7 DIN Muting Module Status Indication Breakdown

Status Indicator	Waiting for Reset*	Output OFF	Output ON	Override	Lockout
Red	 ON	 ON	 OFF	 ON	 Flashing
Green	 OFF	 OFF	 ON	 ON	 OFF
Yellow	 Flashing	 ON	 OFF	 OFF	 OFF

*If either MSSl or SSl is set to MANUAL, the red Status LED is OFF at power-up.

5.1.2 Controls

5.1.2.1 Backdoor Timer

WARNINGS!

BACKDOOR TIMER

AN INFINITE TIME FOR THE BACKDOOR TIMER (I.E., DISABLING) SHOULD BE SELECTED ONLY IF THE POSSIBILITY OF AN INAPPROPRIATE OR UNINTENDED MUTE CYCLE IS MINIMIZED, AS DETERMINED AND ALLOWED BY THE MACHINE'S RISK ASSESSMENT. IT IS THE USER'S RESPONSIBILITY TO ENSURE THAT THIS DOES NOT CREATE A HAZARDOUS SITUATION.

The Backdoor Timer allows the User to select a maximum period of time that muting is allowed to occur. This feature delays the intentional defeat of the muting devices to initiate an inappropriate mute. It is also useful for detecting a common mode failure that would affect all mute devices in the application.

The timer begins when the second muting device makes the simultaneity requirement ([Simultaneity Requirement, see page 67](#))(within 3 s of the first device), and allows a mute to continue for the predetermined time. After the timer expires, the mute ends – no matter what the signals from the mute devices indicate. If the MSSl is open, the OSSD outputs turn OFF and must be manually reset (if Module is configured for Manual Reset). The Override function can be activated (see [block 1.11.11 on page 8](#)) to force the OSSDs to switch ON in order to clear the obstruction.

If the Backdoor Timer expires, a 50 error code is displayed until all mute device inputs are open and the MSSl is active/closed.

The Backdoor Timer can be disabled (i.e., set for infinite time). See [table 4 on page 22](#) and configure DIP switches 5 and 6 for Backdoor Time-Out OFF.

5.1.2.2 Manual Key Reset Switch (optionally supplied)

WARNING!

LOCATION OF THE MANUAL RESET SWITCH

THE Reset Switch MUST BE LOCATED OUTSIDE OF AND NOT BE ACCESSIBLE FROM WITHIN, THE AREA OF DANGEROUS MOTION, AND IT MUST BE POSITIONED SO THAT THE AREA OF DANGEROUS MOTION MAY BE OBSERVED BY THE SWITCH OPERATOR DURING THE RESET OPERATION.



The Manual Reset Switch connects to terminals X1 and

X2 of the Reset connector (see figure 17 on page 53).

Any reset switches must be located so that a Reset is possible only from outside, and in full view of, the hazardous area. The switch must also be out of reach from within the safeguarded space. If any hazardous areas are out of view from the switch location, additional means of guarding must be provided.

The switch should be protected from accidental or unintended actuation (for example: through the use of rings or guards).

Using a key switch provides some level of personal control, because the key may be removed. This delays a Reset while the key is under the control of an individual, but must not be relied upon solely to guard against accidental or unauthorized reset. Spare keys in the possession of others, or additional personnel entering the safeguarded area unnoticed may create a hazardous situation.

For information on the Reset Routine see block 4.5.1.1 on page 25.

5.1.2.3 E-Stop Switch (optionally supplied)

Used for an emergency situation only to stop the safeguarded machine in conjunction with the DIN Muting Module.

The Emergency Stop is activated by pressing the Push Button Switch (figure 10 on page 38).

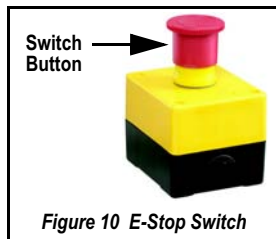

The Push Button Switch has a reset function for the Emergency Stop circuit also.

For typical connection layouts refer to figure 33 on page 57, figure 34 on page 57 and figure 35 on page 57.

5.2 NORMAL OPERATION

5.2.1 General

During normal operation, the Module's three status indicators (red, green and yellow) are as shown in figure 9 on page 37 and table 7 on page 37. In addition, green or yellow indicators adjacent to each of the Module's inputs/interfaces come ON to verify an active state of that circuit.

During normal operation, the Diagnostic Display reads — solid or, if during the mute cycle, flashing —. If the 30 s or 60 s Backdoor Timer feature is selected, the Diagnostic Display begins to count down in seconds. If the 30 min. Backdoor Timer feature is selected, the timer countdown is in minutes. A flashing dash — appears on the display if the Backdoor Timer is OFF (infinite). If the Red status indicator be-



gins to flash —, the number that appears in the Display signifies

an error; see block 6.2.1.2 on page 45 for more information.

See block 4.5.1 on page 25 for information on the reset routine.

5.2.2 Normal Start-up

- 1) Carry out procedures as detailed in block 6.1.7.2 on page 43 and block 6.1.7.3 on page 44.

5.2.3 Running Procedures

5.2.3.1 Responding to a Lockout Condition

Refer to block 6.2.1.1 on page 45.

5.2.4 Shutdown Procedure

- 1) Remove power from DIN Muting Module.

6 MAINTENANCE

WARNINGS!

BEFORE CARRYING OUT MAINTENANCE ON THE EQUIPMENT
READ THE SAFETY INFORMATION CONTAINED IN [Chapter 1 on Page 1](#).

SHUT DOWN MACHINERY BEFORE SERVICING

THE MACHINERY CONNECTED TO THE MODULE MUST NOT BE OPERATING AT ANY TIME DURING THIS PROCEDURE. YOU MAY BE WORKING CLOSE TO A HAZARDOUS AREA OF YOUR MACHINERY WHILE SERVICING THE MODULE. SERVICING THE MODULE WHILE THE HAZARDOUS MACHINERY IS OPERATING COULD RESULT IN SERIOUS BODILY INJURY OR DEATH.

6.1 PREVENTIVE MAINTENANCE

6.1.1 Warranty Service

Banner Engineering Corp. warrants its products to be free from defects for one year. *Banner Engineering Corp.* will repair or replace, free of charge, any product of its manufacture found to be defective at the time it is returned to the factory during the warranty period. This warranty does not cover damage or liability for the improper application of *Banner* products. This warranty is in lieu of any other warranty either expressed or implied.

 Do not attempt any repairs to the DIN Muting Module. It contains no field-replaceable components. Return the Module to the factory for warranty replacement.

If it becomes necessary to return a system component to the factory, contact the *Banner Corporate Office* as listed on [page 69](#).

The *Banner* Factory Application Engineering group will try to determine what the fault or problem is. If it is concluded that a component is defective and must be returned, an RMA (Return Merchandise Authorization) number for the paperwork will be sent, together with the shipping address for returning the defective component(s).

The component(s) should be packed carefully. Damage which occurs during return shipping is not covered by warranty.

6.1.2 Periodic Checkout Requirements

WARNING!

VERIFY PROPER OPERATION

THE MUTING MODULE AND SAFETY SYSTEMS CAN DO THE JOB FOR WHICH IT WAS DESIGNED ONLY IF IT AND THE MACHINE IT GUARDS ARE OPERATING PROPERLY, BOTH SEPARATELY AND TOGETHER. IT IS THE USER'S RESPONSIBILITY TO VERIFY PROPER OPERATION, ON A REGULAR BASIS, AS INSTRUCTED IN [Chapter 6 on Page 39](#). IF THE MUTING MODULE, SAFETY SYSTEMS, AND THE GUARDED MACHINE DO NOT PERFORM EXACTLY AS OUTLINED IN THE CHECKOUT PROCEDURES, THE CAUSE OF THE PROBLEM MUST BE FOUND AND CORRECTED BEFORE THE SYSTEM IS PUT BACK INTO SERVICE. FAILURE TO CORRECT SUCH PROBLEMS CAN RESULT IN SERIOUS BODILY INJURY OR DEATH.

In addition to the check-outs that are performed by a [Qualified Person as specified in block 1.9.2 on Page 3](#) or persons at the time that the Module is installed and put into service, the functioning of the safeguarding and the machine must be verified on a regular periodic basis to ensure proper operation. This is absolutely vital and necessary. Failure to ensure proper operation can lead to serious injury or death.

See [Chapter 6 on Page 39](#) for checkout schedules and procedures.

Before starting a Checkout, each procedure should be read in its entirety, to ensure understand ability.

Refer all questions to the *Banner Corporate Office* as listed on [page 69](#).

Check-outs must be performed as detailed in [block 6.1.3 on page 39](#) below and results should be recorded and kept in the appropriate place (e.g., near the machine, and/or in a technical file).

6.1.3 Schedule of Check-outs

6.1.3.1 Initial Checkout

The procedure for Initial checkout of the DIN Muting Module and its interconnected components is described in [block 6.1.4 on page 39](#). This procedure is performed at installation, and at any time the System, the guarded machine, or any part of the application is installed or altered. The procedure must be performed by a [Qualified Person as specified in block 1.9.2 on Page 3](#).

6.1.3.2 Commissioning Checkout

The procedure for Commissioning checkout of the DIN Muting Module and its interconnected components is described in [block 6.1.5 on page 39](#). It should be performed after installation or whenever changes are made to the system (either a new configuration of the safety system that includes the DIN Muting Module or changes to the machine). The procedure must be performed by a [Qualified Person as specified in block 1.9.2 on Page 3](#).

6.1.3.3 Daily Checkout

This procedure for the DIN Muting Module is described in [block 6.1.6 on page 41](#) and should be performed at least at the following intervals:

- Each shift change
- Every Machine setup change
- Whenever the system is powered up
- Daily

The procedure must be performed by a [Designated Person as specified in block 1.9.1](#) or a [Qualified Person as specified in block 1.9.2 on Page 3](#).

6.1.3.4 Six Monthly Checkout

This procedure for the DIN Muting Module is described in [block 6.1.7 on page 43](#) and should be performed at least every six months, following installation of the System. The procedure must be performed by a [Qualified Person as specified in block 1.9.2 on Page 3](#).

6.1.4 Initial Checkout

Refer to [block 4.6 on page 31](#).

6.1.5 Commissioning Checkout

Refer to [block 4.8 on page 35](#).

Intentionally Left Blank

6.1.6 Daily/Shift Change Checkout

THIS CHECKOUT PROCEDURE SHOULD BE PERFORMED AT EVERY POWER-UP, SHIFT CHANGE AND MACHINE/EQUIPMENT SETUP

WARNINGS!

DO NOT USE MACHINE UNTIL SYSTEM IS WORKING PROPERLY

IF ALL OF THESE CHECKS CANNOT BE VERIFIED, DO NOT ATTEMPT TO USE THE DIN MUTING MODULE/SAFEGUARDED MACHINE UNTIL THE DEFECT OR PROBLEM HAS BEEN CORRECTED (SEE [block 6.2.1 on page 45](#)). ATTEMPTS TO USE THE SAFEGUARDED MACHINE UNDER SUCH CONDITIONS COULD RESULT IN SERIOUS BODILY INJURY OR DEATH.

BEFORE APPLYING POWER TO THE MACHINE

VERIFY THAT THE SAFEGUARDED AREA IS CLEAR OF PERSONNEL AND UNWANTED MATERIALS (SUCH AS TOOLS) BEFORE APPLYING POWER TO THE SAFEGUARDED MACHINE. FAILURE TO DO SO COULD RESULT IN SERIOUS BODILY INJURY OR DEATH.

- 9) Check carefully for external signs of damage or changes to safety system that includes DIN Muting Module, interfaced safeguards, guarded machine, and their electrical wiring. Any damage or changes found should be immediately reported to management. ☐

WARNING!

DO NOT ATTEMPT TO USE THE SYSTEM

IF ANY OF THESE CHECKS FAIL, DO NOT ATTEMPT TO USE THE SYSTEM UNTIL THE REASON FOR THE FAILURE(S) IS IDENTIFIED AND CORRECTED.

During continuous machine run periods, this checkout must be performed at intervals not to exceed 24 hours. A [Designated Person as specified in block 1.9.1](#) or a [Qualified Person as specified in block 1.9.2 on Page 3](#) must perform the procedure. Checkout results should be recorded and kept on or near the guarded machine.

- 1) Verify that access to guarded area is not possible from any area not protected by safeguards interfaced with safety system that includes the DIN Muting Module. ☐
- 2) Verify fixed guarding or supplementary presence-sensing devices must be installed, wherever needed, to prevent any person from reaching around the light screen or entering into the hazard area. ☐
- 3) Verify that all supplementary guarding devices and fixed guarding are in place and operating properly. ☐
- 4) Verify that safeguards interfaced with the safety system that include the DIN Muting Module have been properly installed and maintained. See relevant instruction manuals or data sheets. ☐
- 5) Verify that Reset switch is mounted outside guarded area, out of reach of anyone inside guarded area, and that key or other means of preventing inadvertent use is in place. ☐
- 6) Verify system(s) checkout procedures for external safety systems connected to MSI and SSI inputs as described by the appropriate manuals. ☐
- 7) Initiate machine motion of guarded machine and during cycle, generate a stop command from safeguarding device. Do not attempt to insert anything into dangerous parts of machine. Upon issuing stop command, dangerous parts of machine should come to a stop with no apparent delay. Upon reset of safeguard and Module, verify that machine does not automatically restart, and that initiation devices must be engaged to restart machine. ☐
- 8) With guarded machine at rest, generate a stop command from safeguarding device(s) and verify that it is not possible for guarded machine to be put into motion. ☐

Intentionally Left Blank

6.1.7 Six Monthly Checkout

THIS CHECKOUT PROCEDURE SHOULD BE PERFORMED EVERY SIX MONTHS

WARNINGS!

DO NOT USE MACHINE UNTIL SYSTEM IS WORKING PROPERLY

IF ALL OF THESE CHECKS CANNOT BE VERIFIED, DO NOT ATTEMPT TO USE THE DIN MUTING MODULE/SAFEGUARDED MACHINE UNTIL THE DEFECT OR PROBLEM HAS BEEN CORRECTED (SEE [block 6.2.1 on page 45](#)). ATTEMPTS TO USE THE SAFEGUARDED MACHINE UNDER SUCH CONDITIONS COULD RESULT IN SERIOUS BODILY INJURY OR DEATH.

BEFORE APPLYING POWER TO THE MACHINE

VERIFY THAT THE SAFEGUARDED AREA IS CLEAR OF PERSONNEL AND UNWANTED MATERIALS (SUCH AS TOOLS) BEFORE APPLYING POWER TO THE SAFEGUARDED MACHINE. FAILURE TO DO SO COULD RESULT IN SERIOUS BODILY INJURY OR DEATH.

PERFORMING SIX MONTHLY CHECKOUT

THE SIX MONTHLY CHECKOUT PROCEDURE MUST BE PERFORMED BY A [Qualified Person](#) as specified in [block 1.9.2 on Page 3](#).

 Checkout results should be recorded and kept on or near the safeguarded machine.

6.1.7.1 Preparation

Prepare the DIN Muting Module for this checkout as follows:

- 1) Referring to [figure 7 on page 22](#) and [table 4 on page 22](#) verify configuration is the same as for required machine operation.

6.1.7.2 Safeguarding Device(s) Checkout

- 1) Examine safeguarded machine to verify that it is of a type and design compatible with Safeguarding Device(s) system that has been installed (see [block 1.12 on page 10](#)).
- 2) Verify system(s) checkout procedures for external safety systems connected to MSSI and SSI inputs as described by appropriate manuals. Do not proceed until all checkout procedures are completed successfully and all problems have been corrected.
- 3) Verify that:
 - Access to any dangerous parts of safeguarded machine is not possible from any direction not protected by Safeguarding Device(s) system, fixed guarding, or supplementary Safeguarding Device(s)
 - Supplementary Safeguarding Device(s) and fixed guarding, as described by appropriate safety standards, are in place and functioning correctly
- 4) Verify that Reset Switch is mounted outside safeguarded area, out of reach of anyone inside safeguarded area, and that means of preventing inadvertent use is in place.
- 5) Examine electrical wiring connections between the Module's OSSD outputs and safeguarded machine's control elements to verify that wiring meets requirements stated in [block 4.7 on page 33](#).
- 6) Ensure that power to safeguarded machine is OFF.
- 7) Apply power to DIN Muting Module.

- 8) Verify that external safety systems are providing a green/Go signal to MSSI and SSI inputs and that Green MSSI and SSI indicators (two pairs of LEDs located near each terminal) are ON.



When configured for a Manual Reset, yellow status indicator is



- 9) Perform a Manual Reset as detailed in [block 4.5.1.1 on page 25](#).

Verify that green status indicator is ON steady.



 A Red flashing status indicator signifies a lockout condition. Refer to [block 6.2.1 on page 45](#) for information.



- 10) In a non-muted condition, generate a stop command from safeguarding device connected to MSSI (for example, interrupt defined area of a safety light screen).
- 11) Verify that MSSI Channel A and B and the status indicator LEDs show green OFF with red and yellow ON.



- 12) In order, reset safeguard and then Module (in Manual Reset).
- 13) Generate a stop command from safeguarding device connected to SSI (for example, actuate E-stop button).
- 14) Verify that SSI Channel A and B and status indicator LEDs show green OFF with red and yellow ON.



- 15) In order, reset safeguard and then Module (in Manual Reset).
- 16) Apply power to guarded machine and verify that machine does not start up.
- 17) Generate a stop command from safeguarding device connected to SSI and MSSI in a non-muted condition.
- 18) Verify that it is not possible for the guarded machine to be put into motion while either stop commands are present.
- 19) In order, reset safeguard and then Module (in Manual Reset).
- 20) Initiate machine motion of guarded machine and while it is moving, as in [Step 17](#) above, generate a stop command from each safeguarding device.

 Do not attempt to insert anything into dangerous parts of machine.

- 21) Upon issuing stop command, check that dangerous parts of machine come to a stop with no apparent delay.
- 22) Upon reset of safeguard and Module, verify that machine does not automatically restart, and that initiation devices must be engaged to restart machine.

- 23) Remove electrical power from Module. ☐
- 24) Check all OSSD outputs immediately turn OFF and should not be capable of turning ON until power is re-applied and a reset is accomplished. ☐
- 25) Test machine stopping response time, using an instrument designed for that purpose, to verify that it is same or less than overall system response time specified by machine manufacturer. (Banner's Applications Engineering Department may be able to recommend a suitable instrument.) ☐

Do not continue operation until the entire checkout procedure is complete and all problems are corrected.

6.1.7.3 Muting Checkout

- 1) Verify that DIN Muting Module has been Reset and Status indicator shows steady green. 

If Status indicator is flashing yellow  (indicating DIN Muting Module is waiting for a Reset of a latched condition), perform a Manual Reset as detailed in [block 4.5.1.1 on page 25](#).

If at any time red status indicator begins to flash , a lockout condition exists. Refer to [block 6.2.1.1 on page 45](#) to determine cause of lockout. ☐

At all times ensure that personnel are not exposed to any hazard.

- 2) Mute system by blocking (or activating) both mute devices (typically M1- M2) simultaneously (within 3 s). ☐
- 3) Verify that Mute indicator(s) show steady green. If not, check indicator(s) and wiring.



Check also Diagnostic Display for error codes. ☐



- 4) Generate a **stop** command from Safeguarding Device(s) connected to MSSI. Verify that MSSI Channel A and B are OFF and green Status indicator is ON. ☐



If the 30 or 60-second Backdoor Timer feature has been selected, the Diagnostic Display begins to count down; otherwise a flashing dash appears on the display.



- 5) Clear or Reset Safeguarding Device(s) (before Backdoor Timer expires) and verify MSSI channel indicators are steady green.

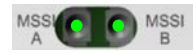

Clear (deactivate) Mute devices before Backdoor Timer expires and verify Mute indicator(s) go OFF.



Status indicator should remain steady green.  ☐

- 6) Verify that it is not possible for a single individual to initiate a mute condition by triggering Mute devices (for example, by blocking both photoelectric beams or actuating both switches) and access hazard without being detected and issuing a stop command to machine (where status indicator LEDs show green

OFF with red and yellow ON  and a Reset of latch condition is required). ☐

At all times ensure that personnel are not exposed to any hazard.

- 7) Verify that it is not possible for personnel to pass in front of, behind, or next to the muted object without being detected and without issuing a stop command to machine. ☐
- 8) If one-way (directional) muting has been selected, verify that system can not be muted by blocking (or activating) M3-M4 before M1-M2. ☐

6.1.7.4 General

If any decrease in machine braking ability has occurred, make the necessary clutch/brake repairs, readjust safeguard Minimum safety Distance (S) appropriately, record the new S calculation, and re-perform the Daily Checkout procedure. ☐

- 1) Examine and test MPCEs and any intermediary controls (such as interface modules) to verify that they are functioning correctly and are not in need of maintenance or replacement. ☐
- 2) Inspect safeguarded machine to verify that no other mechanical or structural problems could prevent machine from stopping or assuming an otherwise safe condition when signalled to do so by DIN Muting Module system. ☐
- 3) Examine and inspect machine controls and connections to Safeguarding Device(s) system to verify that no modifications have been made which adversely affect System. ☐

⚠ WARNING!

DO NOT ATTEMPT TO USE THE SYSTEM

IF ANY OF THESE CHECKS FAIL, DO NOT ATTEMPT TO USE THE SYSTEM UNTIL THE REASON FOR THE FAILURE(S) IS IDENTIFIED AND CORRECTED.

6.2 CORRECTIVE MAINTENANCE

6.2.1 Trouble Shooting

! WARNING!

POWER FAILURES

POWER FAILURES OR OTHER MODULE LOCKOUT CONDITIONS SHOULD ALWAYS BE INVESTIGATED IMMEDIATELY BY A [Qualified Person as specified in block 1.9 on Page 3](#). A LOCKOUT IS A DEFINITE INDICATION OF A PROBLEM AND SHOULD BE INVESTIGATED AT ONCE. ATTEMPTS TO CONTINUE TO OPERATE MACHINERY BY BY-PASSING THE MODULE ARE DANGEROUS AND COULD RESULT IN SERIOUS BODILY INJURY OR DEATH.

SHUT DOWN MACHINERY BEFORE SERVICING

THE MACHINERY CONNECTED TO THE MODULE MUST NOT BE OPERATING AT ANY TIME DURING THIS PROCEDURE. YOU MAY BE WORKING CLOSE TO A HAZARDOUS AREA OF YOUR MACHINERY WHILE SERVICING THE MODULE. SERVICING THE MODULE WHILE THE HAZARDOUS MACHINERY IS OPERATING COULD RESULT IN SERIOUS BODILY INJURY OR DEATH.

! WARNING!

SHOCK HAZARD

ALWAYS DISCONNECT POWER FROM THE DIN MUTING MODULE, SAFETY SYSTEM AND THE SAFEGUARDED MACHINE BEFORE MAKING ANY CONNECTIONS OR REPLACING ANY COMPONENT. USE EXTREME CAUTION TO AVOID ELECTRICAL SHOCK AT ALL TIMES. SERIOUS BODILY INJURY OR DEATH COULD RESULT.

6.2.1.1 Lockout Conditions

A lockout condition causes the OSSD output to turn OFF, sending a stop signal to the safeguarded machine. A lockout condition is indicated by the Red status indicator flashing and an error code appearing in the Diagnostic Display.



To clear a lockout condition:

- 1) Correct cause of error.
- 2) If fault was due to an input failure, fully cycle associated input and/or perform Reset routine as detailed in [block 4.5.1.1 on page 25](#).





6.2.1.2 Diagnostic Display

The DIN Muting Module Diagnostic Display is useful for monitoring the Safeguarding Device(s) system and for quickly diagnosing problems. See [table 8 on page 45](#) for a list of status codes and their meanings, along with recommended corrective actions.

Table 8 Diagnostic Display Breakdown

Status/ Error Code	Condition/ Error	Action
Steady	System OK	n/a
Flashing	Mute Cycle	n/a
31	OSSD Output Error	- One OSSD is shorted to power/ground - OSSDs are shorted together
32	Reset Input Error	- Reset Input shorted/closed
33	Module Error	- Excessive EMI/RFI noise - Internal failure, replace DIN Muting Module
34	MSSI Error*	- One or both channels shorted to power or ground - Input channels shorted together - One channel did not open - Failed simultaneity (> 3 s) - Excessive EMI/RFI noise
35	Override Error	- Override Input closed at power-up - Check Override Input wiring and connector - Excessive EMI/RFI noise
36	Mute Lamp Error	- Check/Replace Lamp (open or short) - Check wiring and connector - Check DIP switch settings
37	DIP switch Error	- Check DIP switch settings - Replace Module
38	EDM 1 Error	- Check wiring - Check operation of device(s) under control - Check DIP switch settings - Switching transition > 200 ms - Excessive EMI/RFI noise - EDM open > 200 ms after OSSDs go OFF (if dropout time verification check on) - EDM not closed at start-up
39	EDM 2 Error	- Verify that input 2 is open (single-channel EDM selected) - Check wiring - Check operation of device(s) under control - Check DIP switch settings - Excessive EMI/RFI noise - EDM not closed at start-up (Y3–Y4)

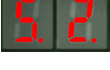
Table 8 Diagnostic Display Breakdown

Status/ Error Code	Condition/ Error	Action
	2-Channel EDM Error	<ul style="list-style-type: none"> - Check wiring - Check operation of device(s) under control - Failed simultaneity between EDM1 & EDM2 (> 200 ms) - EDM open > 200 ms after OSSDs go OFF - Replace DIN Muting Module
	Backdoor Timer Expired	<ul style="list-style-type: none"> - Check muting device operation - Check muting device wiring - Check DIP switch settings - See manual block 5.1.2.1 on page 37
	Mute Timing (Simultaneity) Error	<ul style="list-style-type: none"> - The second mute device of a pair (M1–M2 or M3–M4) did not actuate within 3 seconds of the first device. - Check muting device operation - Check wiring
	Mute Enable Open Error	<ul style="list-style-type: none"> - ME input was open when a mute cycle was attempted - Check Mute Enable wiring - Check DIP switch settings
	SSI Input Error*	<ul style="list-style-type: none"> - One or both channels shorted to power or ground - Input channels shorted together - One channel did not open - Failed Simultaneity (> 3 s) - Excessive EMI/RFI noise

*Fault is cleared by cycling the input from closed-to-open-to-closed.

6.2.1.3 Effects of Electrical Noise

The DIN Muting Module is designed and manufactured to be highly resistant to electrical noise and to operate reliably in industrial settings. However, serious electrical noise may cause a random lockout condition.

Check the following if a noise-related error code is displayed and other remedies have not cleared the problem:

- 1) Check for sensor wires or input/output wires routed too close to noisy wiring.

In extreme conditions, it may be necessary to use shielded cabling or relocate the DIN Muting Module, mute devices, and cabling away from the source of the noise.

6.2.1.4 Circuit & Wiring Information

For detailed circuit and wiring diagrams refer to [appendix A1 on page 49](#).

6.2.1.5 Repairs

Do not attempt any repairs to the DIN Muting Module. It contains no field-replaceable components. Return the DIN Muting Module to the factory for warranty repair or replacement.

If it ever becomes necessary to return a DIN Muting Module to the factory, please do the following:

- 1) Contact *Banner* as listed in [Customer Information on page 69](#).
- 2) Pack Module carefully. Damage which occurs in shipping is not covered by warranty.

6.3 SPARE PARTS

This block details Spare Parts information for the DIN Muting Module mostly in table format.

Table 9 Accessories for DIN Muting Module

Type No.	Description	Order Part No.
Solid-State LED Based Mute Lamp		
SSA-ML-W	+24 VDC, white lens	30 620 95
SSA-ML-A	+24 VDC, amber lens	30 704 94
Interface Modules		
Provide forced-guided, mechanically-linked relay (safety) outputs for the EZ-SCREEN System.		
IM-T-9A	Interface module (x3 N/O redundant-output 6 amp contacts)	30 614 25
IM-T-11A	Interface module (x2 N/O redundant-output 6 amp contacts, plus x1 N/C auxiliary contact)	30 614 24
Miscellaneous		
MGA-KS0-1	Switch keyed reset SPST	30 301 40

Table 10 Documentation

Order Part No.	Description
132538	Instruction Manual (European version UK English)
132539	Instruction Manual (European version French)
132540	Instruction Manual (European version German)
132541	Instruction Manual (European version Italian)

Intentionally Left Blank

A1 WIRING & SCHEMATIC DIAGRAMS

A.1.1 WARNINGS FOR WIRING & SCHEMATIC DIAGRAMS

The following is a list of Warnings used in the wiring and schematic diagram

⚡ WARNING!

HIGH VOLTAGE SHOCK HAZARD FOR MODEL MMD-TA-11B

ALWAYS DISCONNECT ALL POWER FROM THE DIN MUTING MODULE AND THE GUARDED MACHINE BEFORE MAKING ANY CONNECTIONS OR REPLACING ANY COMPONENT. USE EXTREME CAUTION TO AVOID ELECTRICAL SHOCK AT ALL TIMES. SERIOUS BODILY INJURY OR DEATH COULD RESULT.

⚠ WARNINGS

PROPER WIRING

THE GENERALIZED WIRING CONFIGURATIONS SHOWN ARE PROVIDED ONLY TO ILLUSTRATE THE IMPORTANCE OF PROPER INSTALLATION. THE PROPER WIRING OF THE MUTING MODULE TO ANY PARTICULAR MACHINE IS SOLELY THE RESPONSIBILITY OF THE INSTALLER AND END USER.

USE OF TRANSIENT SUPPRESSORS

TRANSIENT SUPPRESSORS ARE RECOMMENDED. THEY **MUST** BE INSTALLED ACROSS THE COILS OF THE MACHINE CONTROL ELEMENTS. **NEVER** INSTALL SUPPRESSORS DIRECTLY ACROSS THE OUTPUTS OF THE MODULE! IT IS POSSIBLE FOR SUPPRESSORS TO FAIL AS A SHORT CIRCUIT. IF INSTALLED DIRECTLY ACROSS THE CONTACTS OF THE MODULE, A SHORT-CIRCUITED SUPPRESSOR CREATES AN UNSAFE CONDITION.

TO ENSURE PROPER OPERATION, THE MUTING MODULE OUTPUT PARAMETERS AND MACHINE INPUT PARAMETERS MUST BE CONSIDERED WHEN INTERFACING THE MUTING MODULE SOLID-STATE OSSD OUTPUTS TO THE MACHINE INPUTS.

MACHINE CONTROL CIRCUITRY MUST BE DESIGNED SO THAT:

- THE MAXIMUM CABLE RESISTANCE VALUE BETWEEN THE MUTING MODULE SOLID-STATE SAFETY OUTPUTS AND THE MACHINE INPUTS IS NOT EXCEEDED
- THE MUTING MODULE SOLID-STATE SAFETY OUTPUT MAXIMUM OFF-STATE VOLTAGE DOES NOT RESULT IN AN ON CONDITION
- THE MUTING MODULE SOLID-STATE SAFETY OUTPUT MAXIMUM LEAKAGE CURRENT, DUE TO THE LOSS OF 0V, DOES NOT RESULT IN AN ON CONDITION

FAILURE TO PROPERLY INTERFACE THE OSSD OUTPUTS TO THE GUARDED MACHINE COULD RESULT IN SERIOUS BODILY INJURY OR DEATH.

SERIES CONNECTION OF SAFETY SWITCHES

WHEN MONITORING MULTIPLE GUARDS WITH A SERIES CONNECTION OF MULTIPLE SAFETY INTERLOCK SWITCHES, A SINGLE FAILURE MAY BE MASKED OR NOT DETECTED AT ALL. WHEN SUCH A CONFIGURATION IS USED, PROCEDURES MUST BE PERFORMED REGULARLY TO VERIFY PROPER OPERATION OF EACH SWITCH. SEE [Monitoring Series-Connected Safety Switches on page 29](#) FOR MORE INFORMATION. FAILURE TO DO SO COULD RESULT IN SERIOUS INJURY OR DEATH.

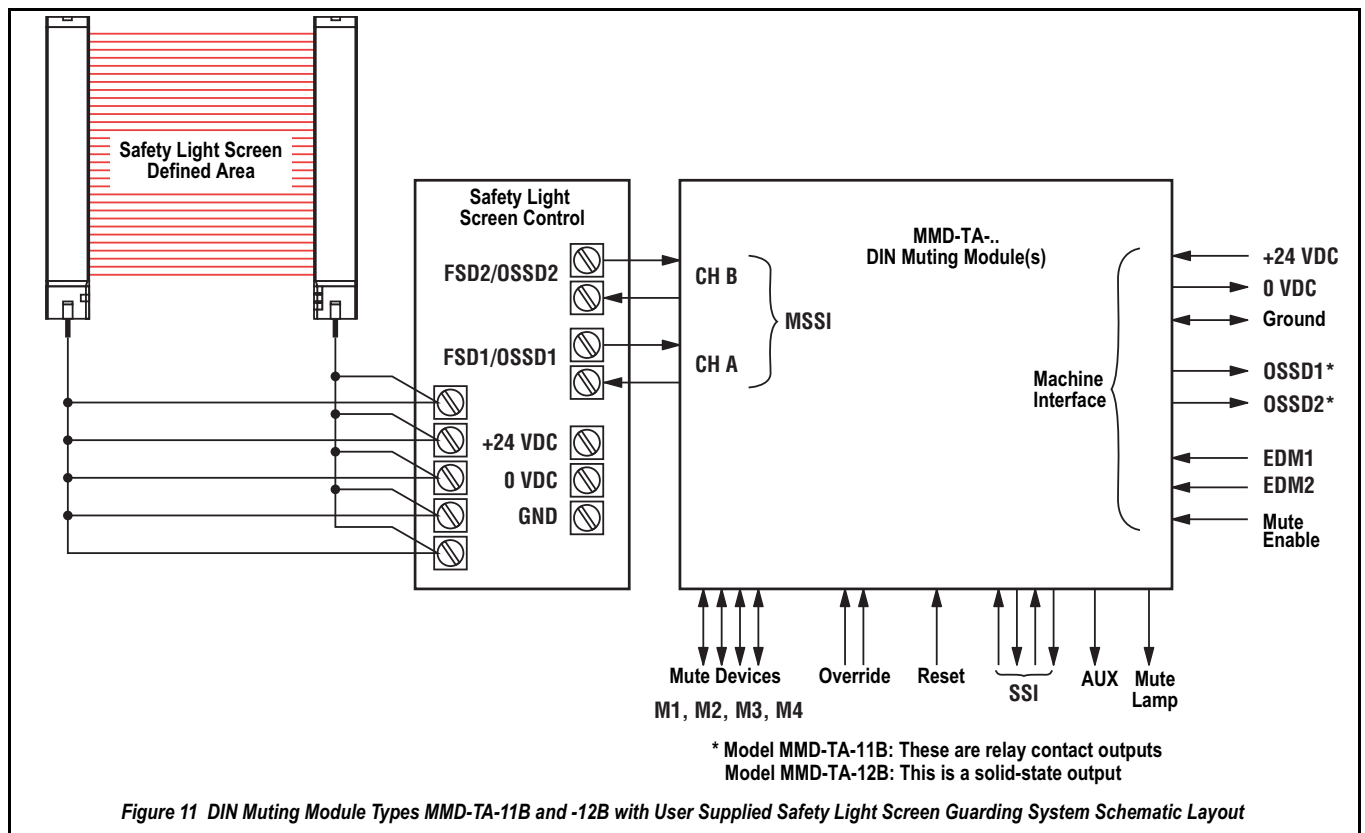
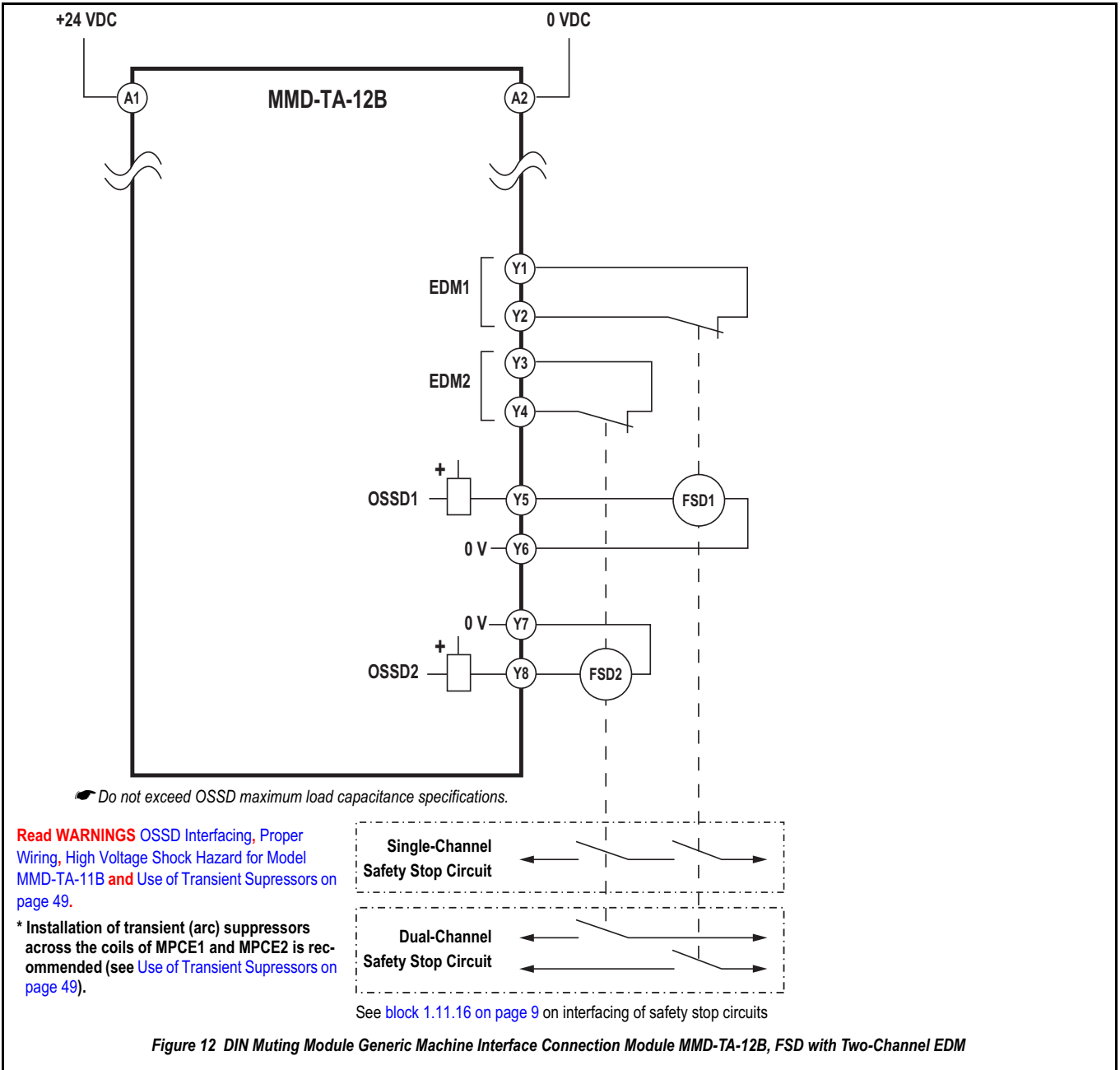

Figure 11 DIN Muting Module Types MMD-TA-11B and -12B with User Supplied Safety Light Screen Guarding System Schematic Layout



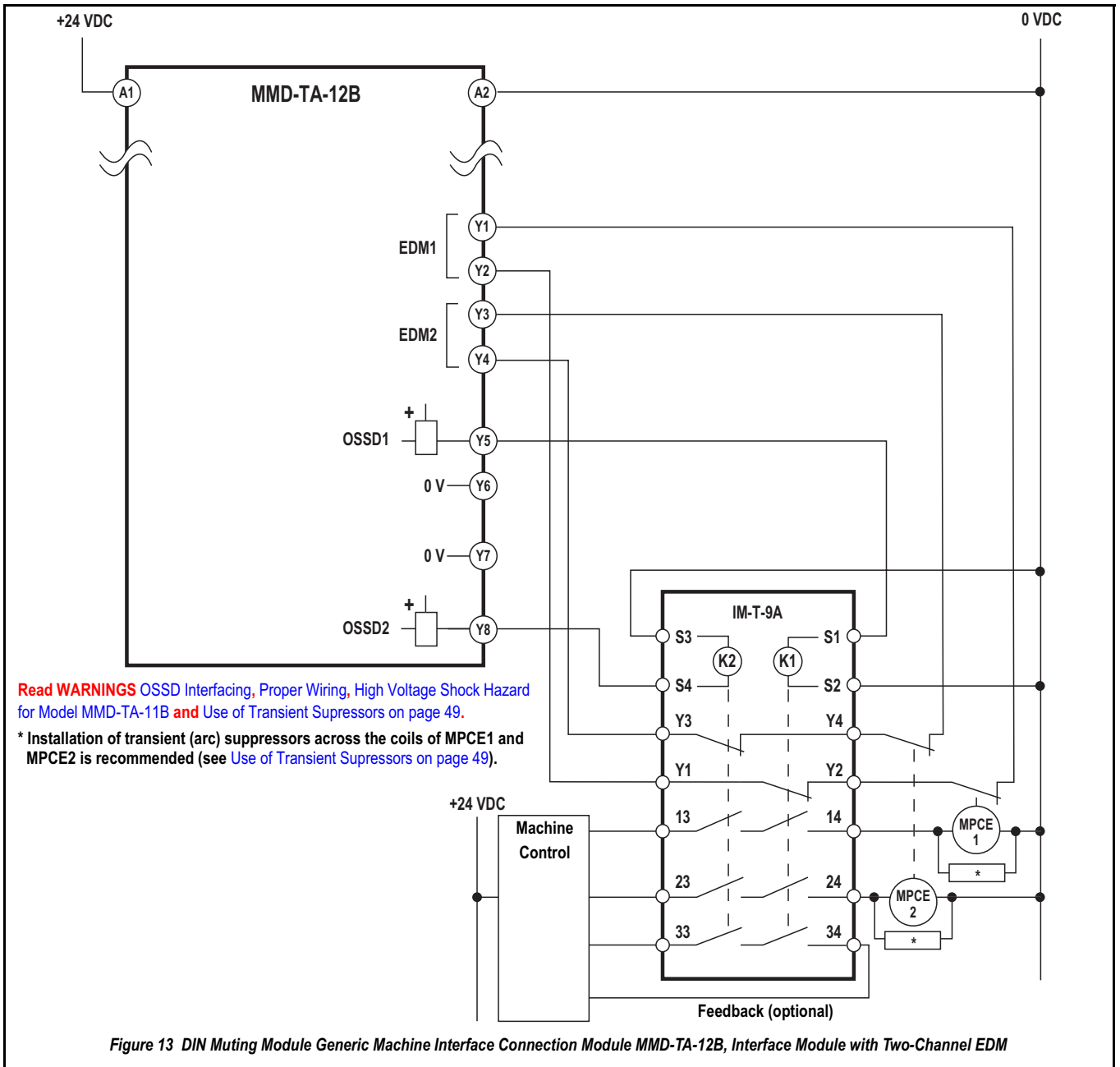

Figure 13 DIN Muting Module Generic Machine Interface Connection Module MMD-TA-12B, Interface Module with Two-Channel EDM

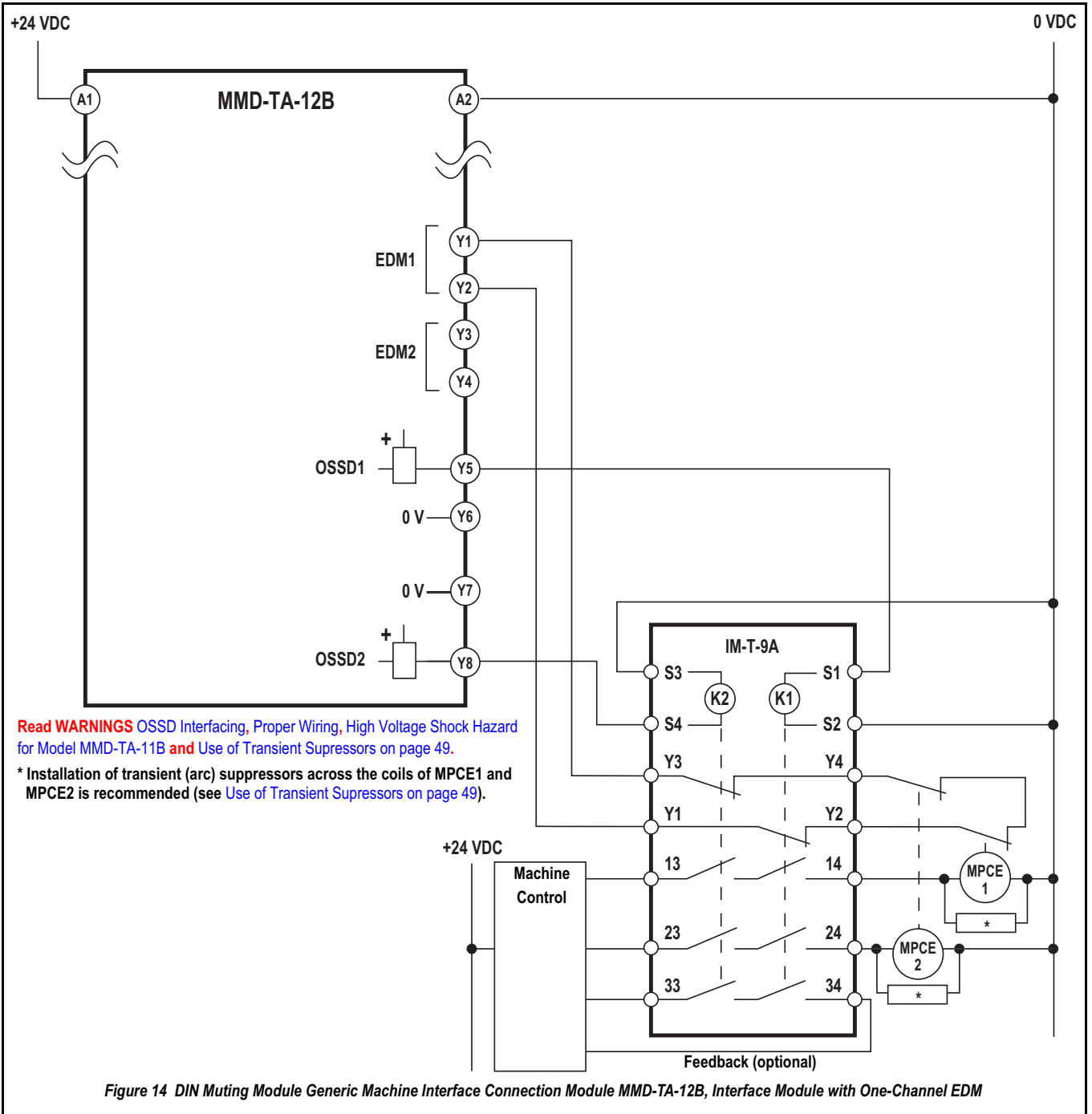
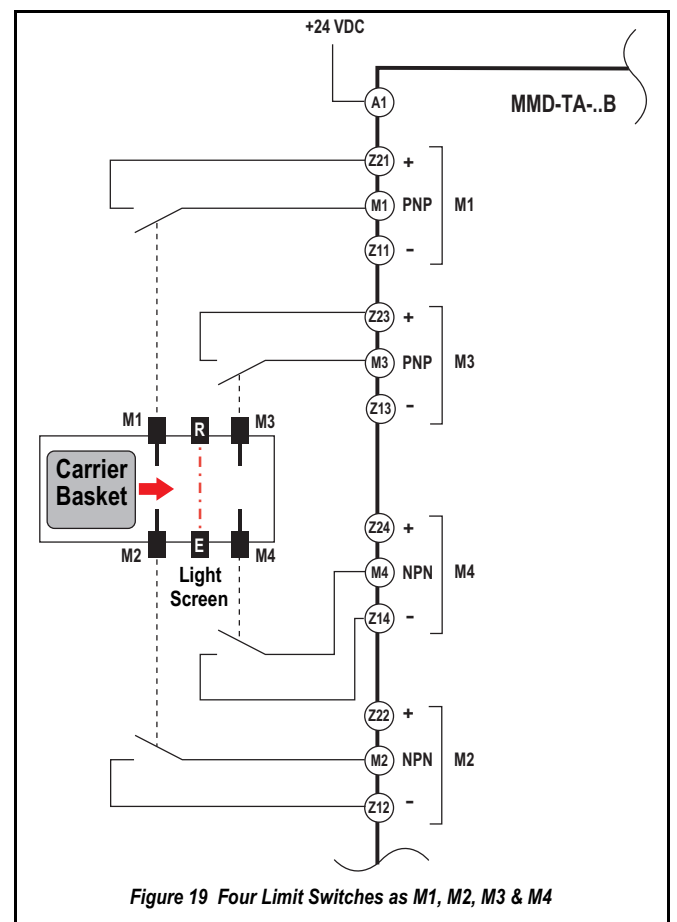
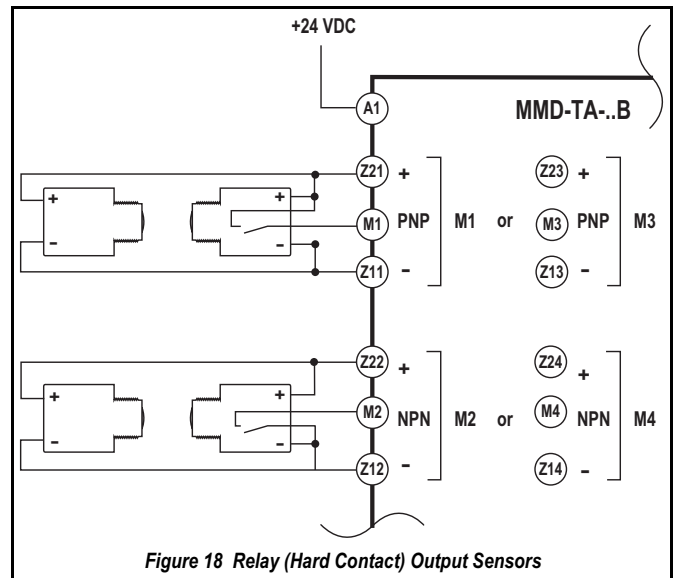
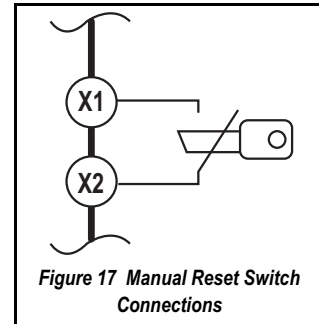
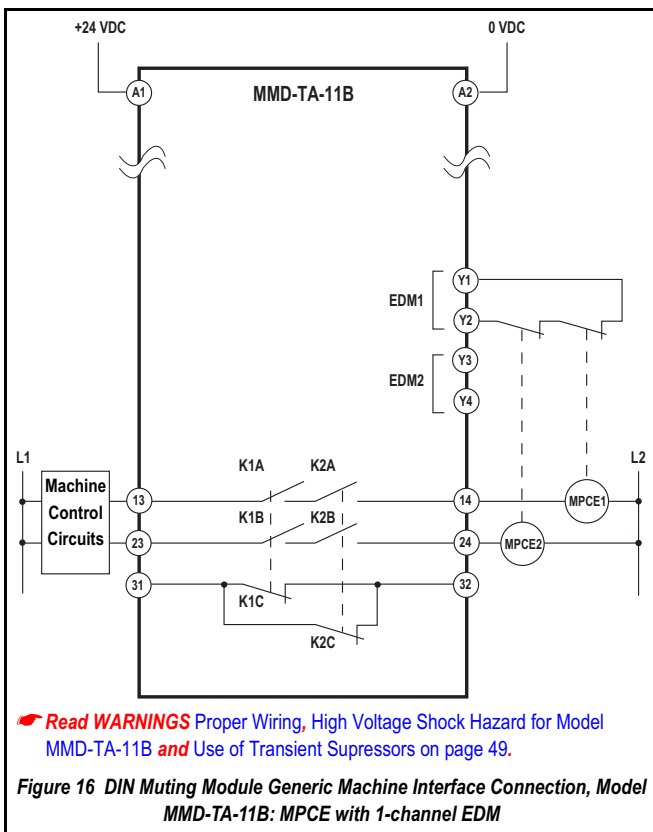
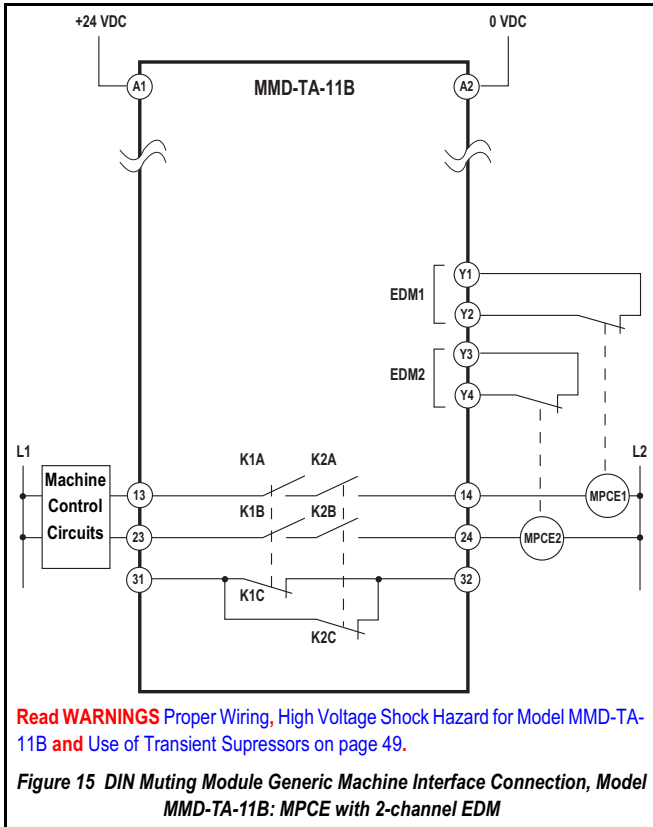
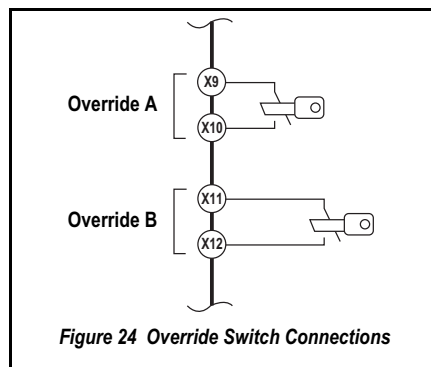
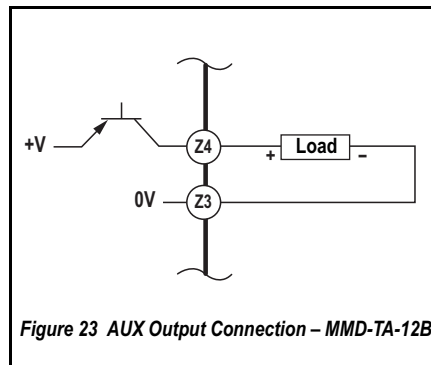
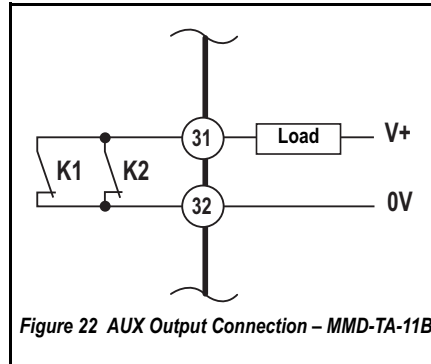
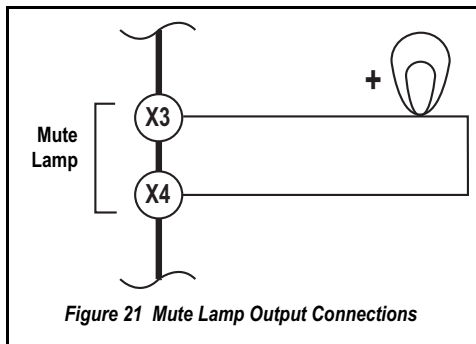
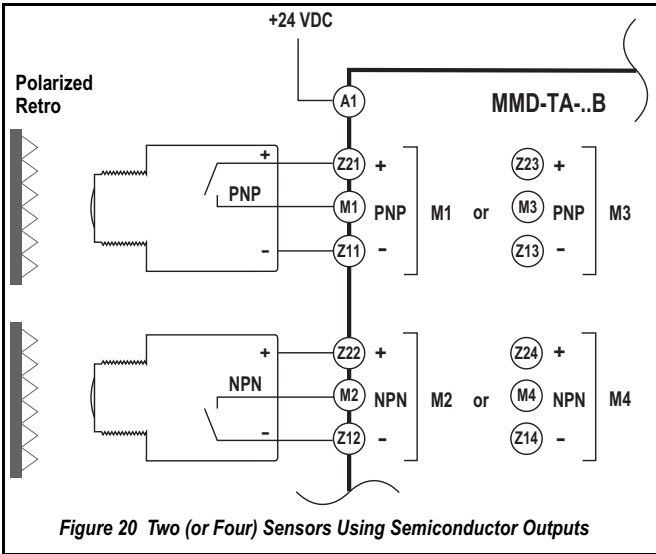
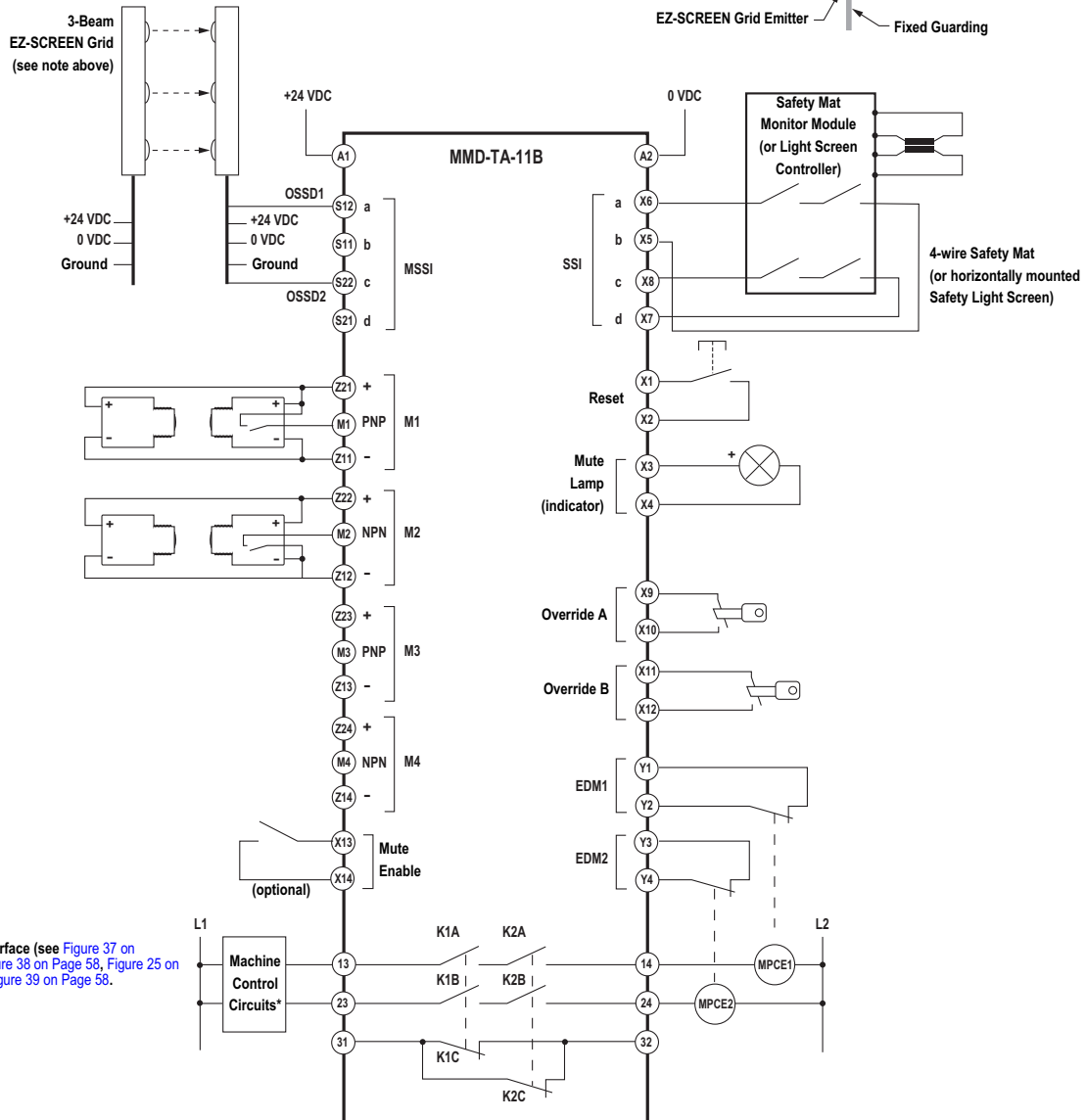
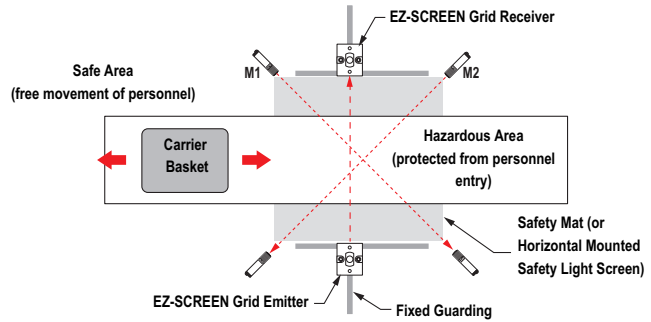

Figure 14 DIN Muting Module Generic Machine Interface Connection Module MMD-TA-12B, Interface Module with One-Channel EDM





Depending on the application, the 3-beam EZ-SCREEN Grid system shown typically would be configured for Trip Output (Automatic Reset). The Muting Module's manual reset would be used to reset the system in the event of a stop command being sent to the machine interface. This allows the EZ-SCREEN to be interrupted as materials pass through during a muted condition, without requiring a reset each time a blocked condition occurs.



Machine Interface (see Figure 37 on Page 58, Figure 38 on Page 58, Figure 25 on Page 55 & Figure 39 on Page 58.)

Figure 25 Interfacing Supplementary Safeguarding to Prevent Personnel from Entering the Hazardous Area During the Mute

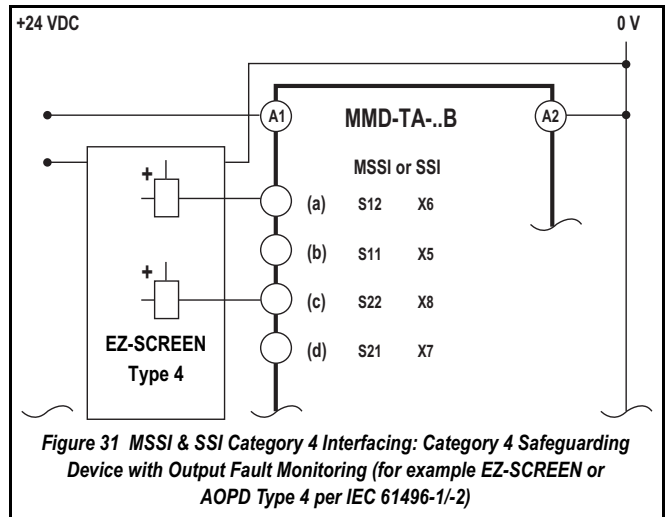
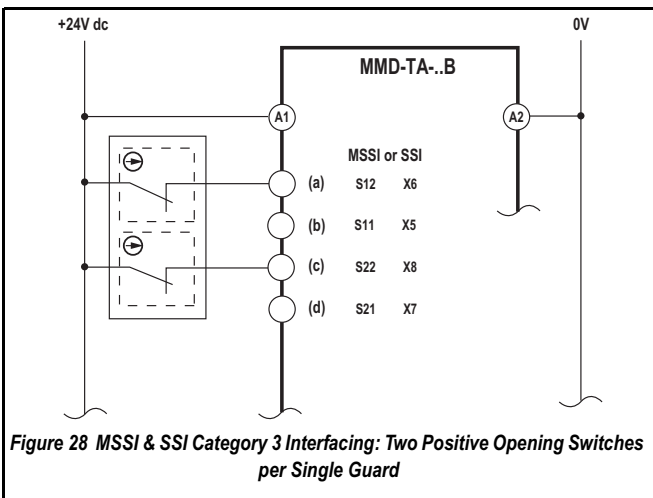
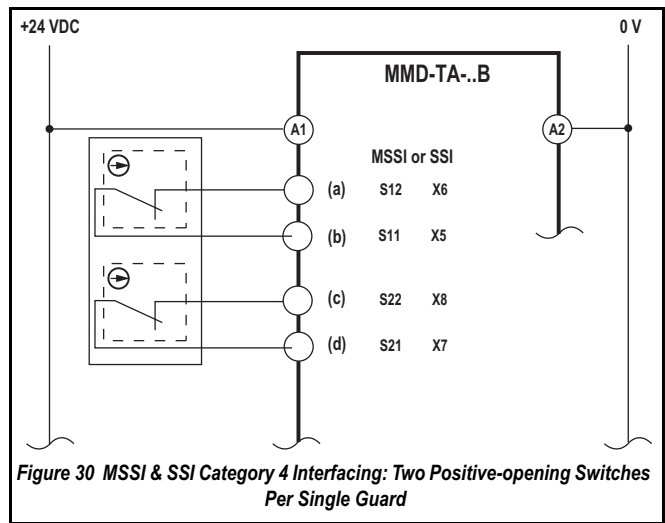
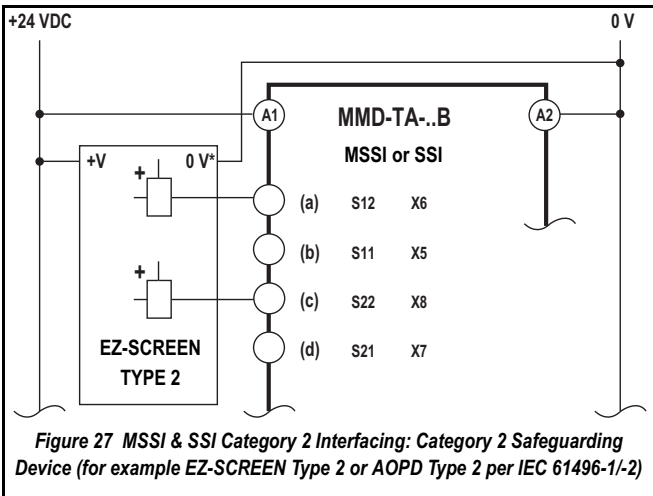
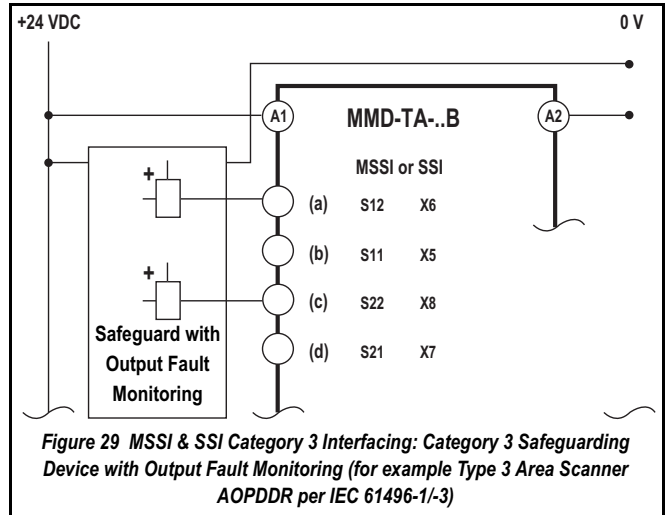
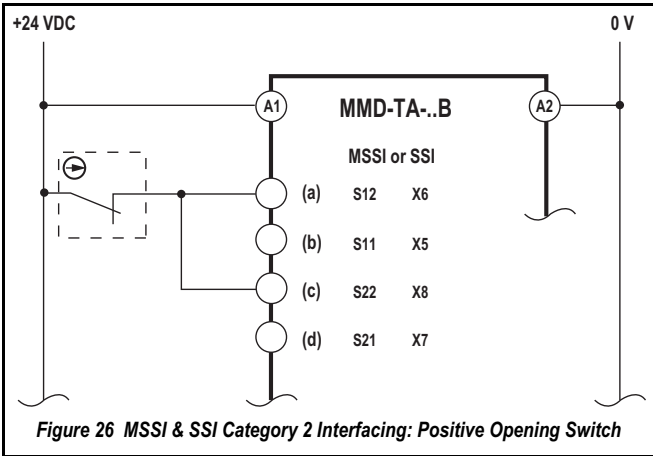

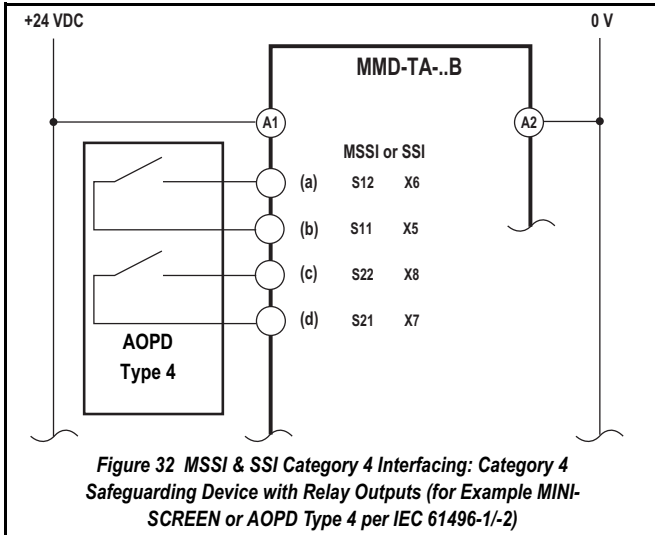

Figure 32 MSSI & SSI Category 4 Interfacing: Category 4 Safeguarding Device with Relay Outputs (for Example MINI-SCREEN or AOPD Type 4 per IEC 61496-1/-2)

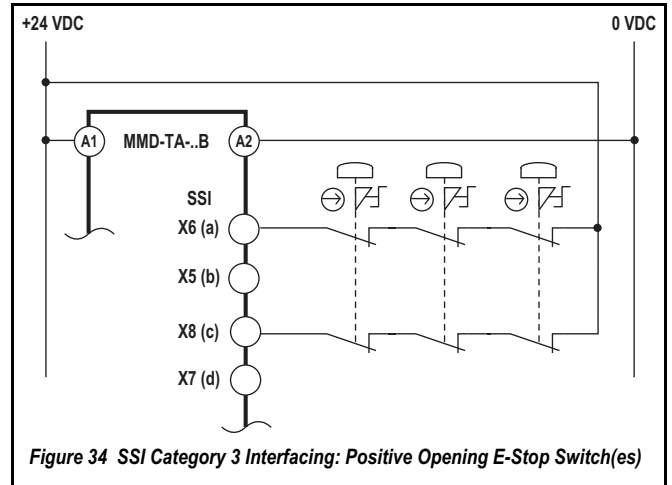

Figure 34 SSI Category 3 Interfacing: Positive Opening E-Stop Switch(es)

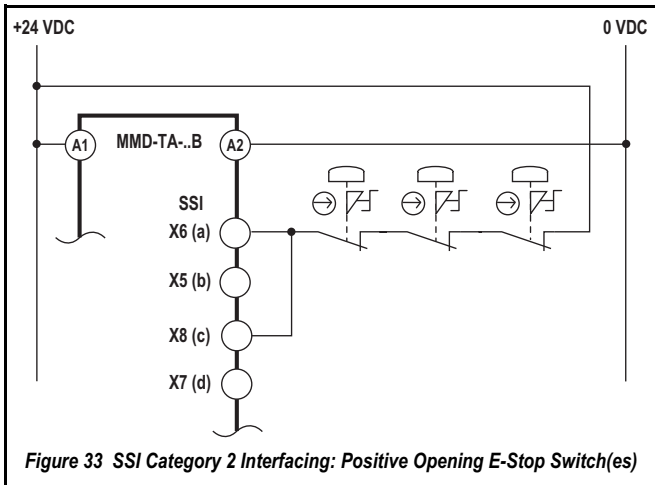

Figure 33 SSI Category 2 Interfacing: Positive Opening E-Stop Switch(es)

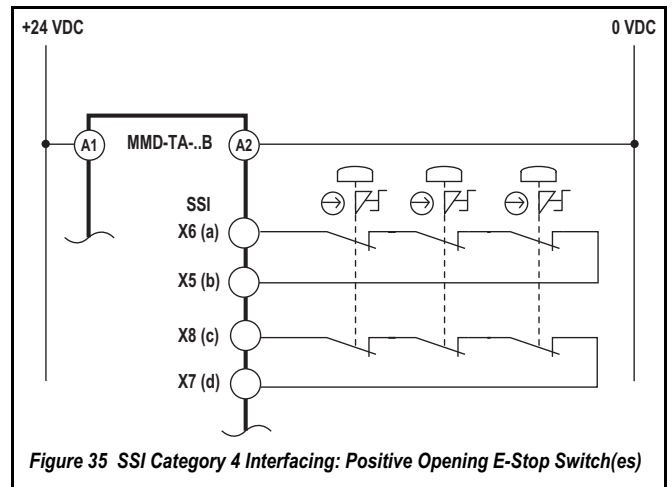

Figure 35 SSI Category 4 Interfacing: Positive Opening E-Stop Switch(es)

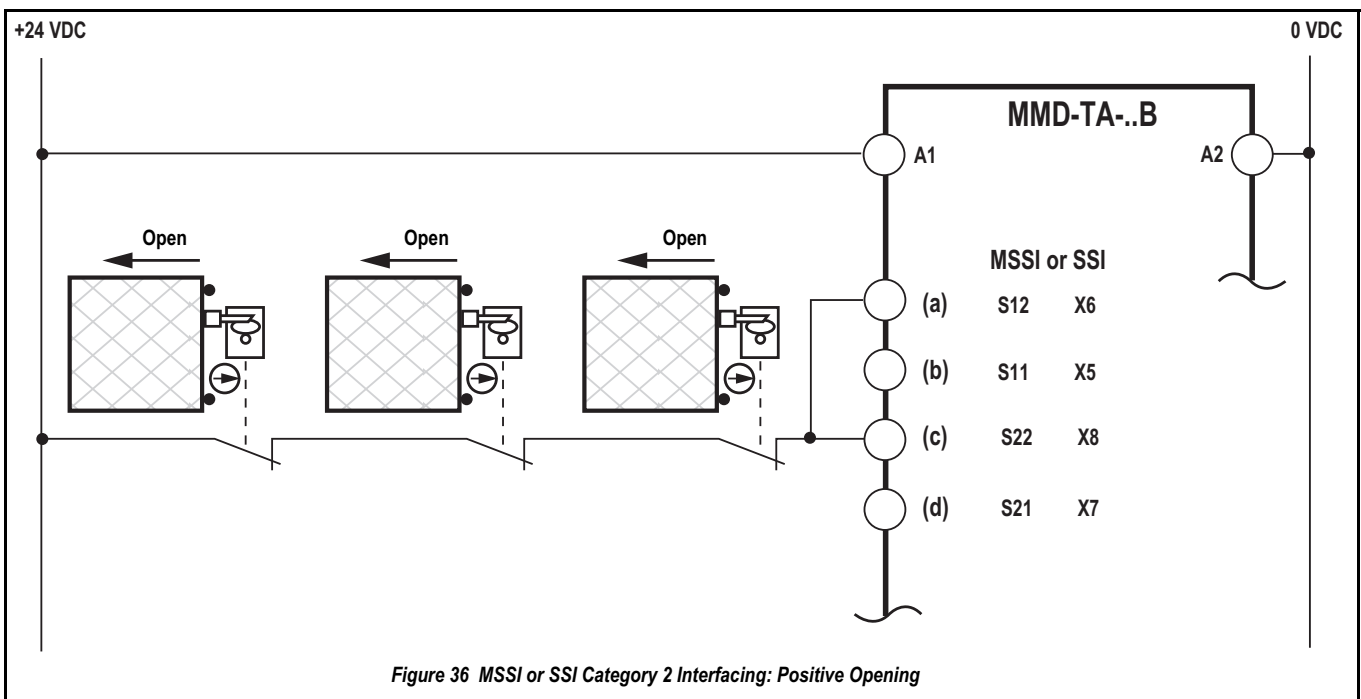
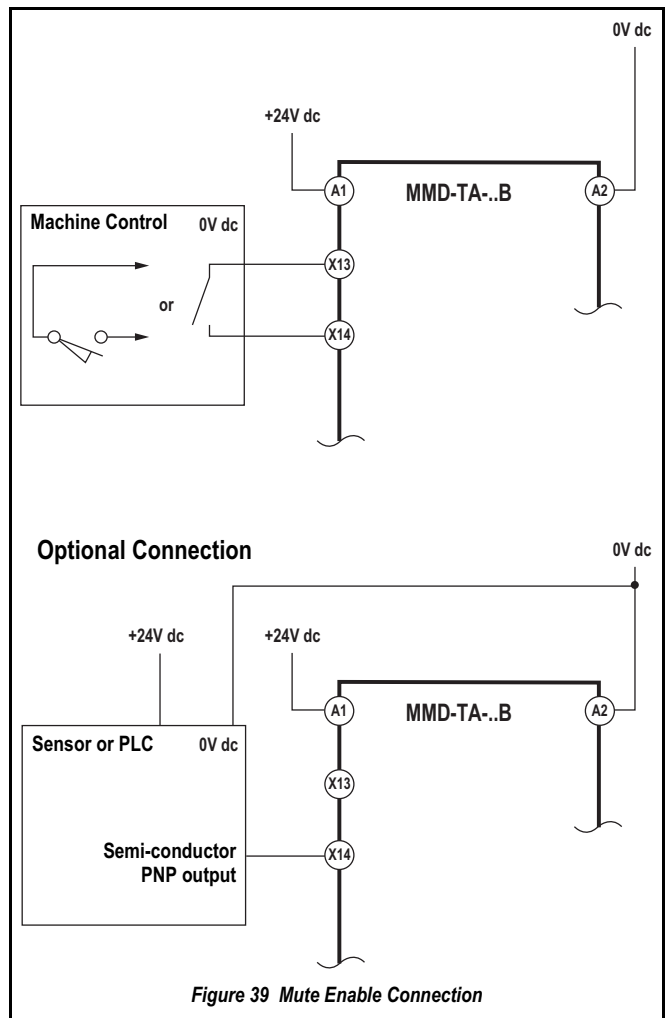
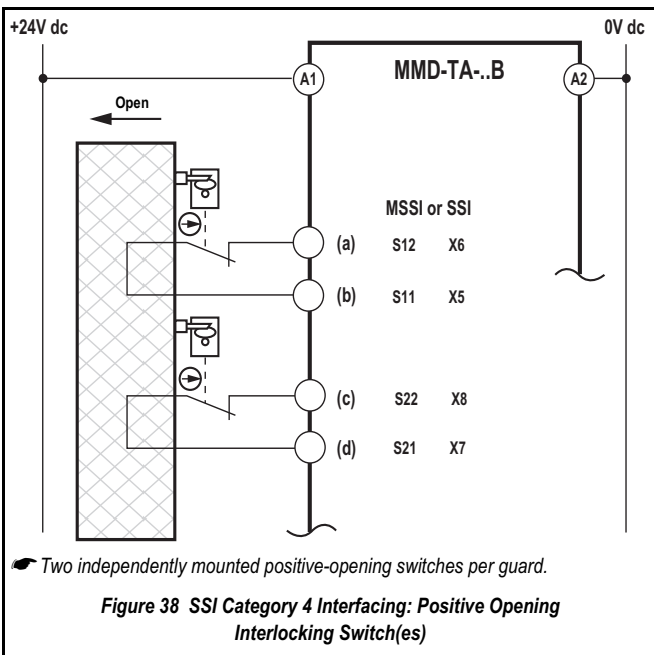
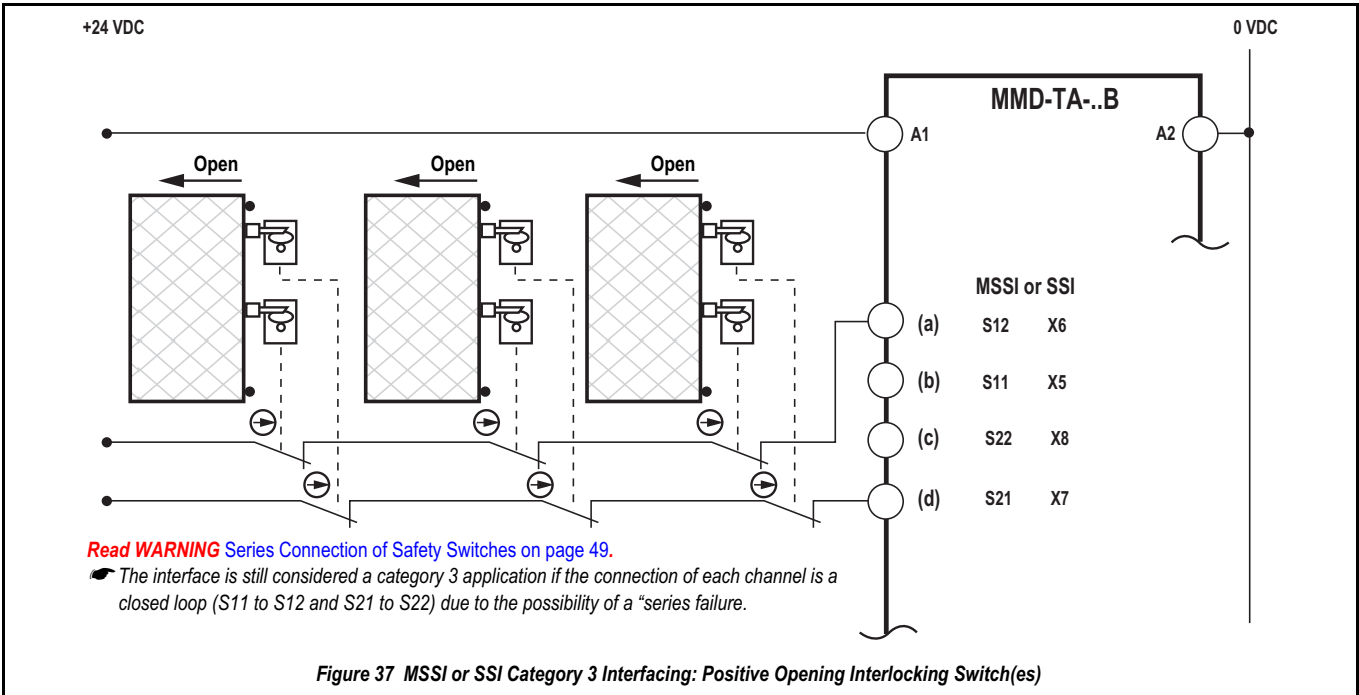

Figure 36 MSSI or SSI Category 2 Interfacing: Positive Opening



A2 MUTE TIMING SEQUENCES

MUTING SEQUENCE WITH TWO MUTING DEVICES (figure 40 on page 59)

As an example, X-pattern Entry/Exit System (see figure 42 on page 61)

DIP Switch Configuration* (refer to block 4.3 on page 22)

- MSSI Auto or Manual ResetSW1 = OFF (Manual)
- SSI Auto or Manual ResetSW2 = OFF (Manual)
or ON (Auto)
- One-Way MutingSW3 = OFF (1-way)
- Two-/One-Channel EDMSW4 = OFF (2 CH)
- Backdoor TimerSW5&6 = OFF (30 s)
- Monitored Muting LampSW7 = OFF (Mon)
- Mute on Power-upSW8 = OFF (Disable)

*Both DIP switch Bank A and Bank B.

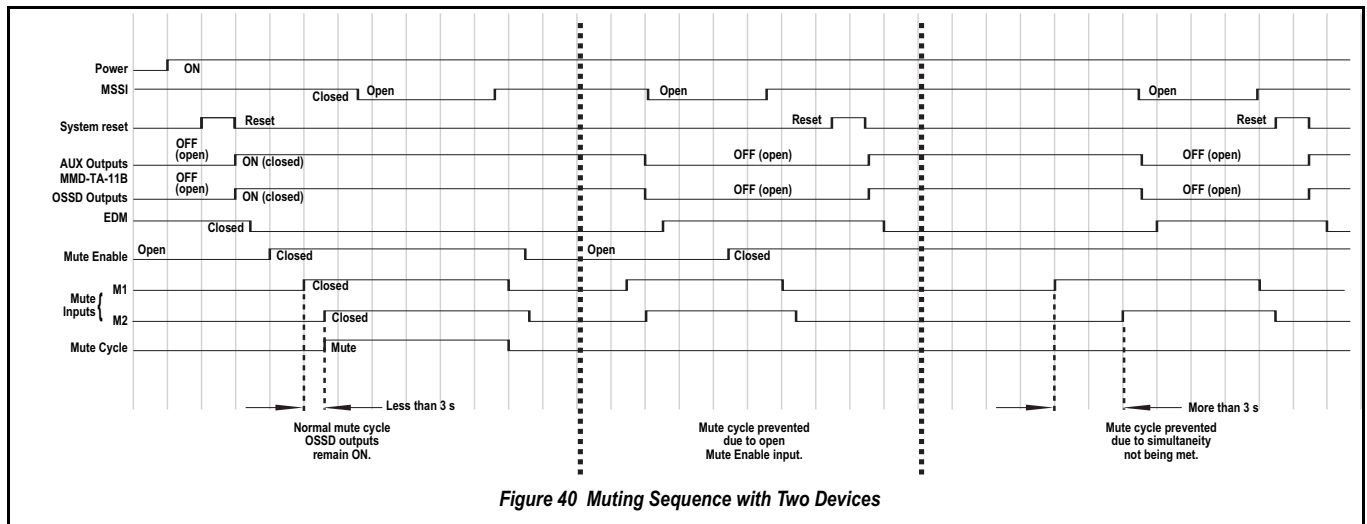

MUTING SEQUENCE WITH FOUR MUTING DEVICES (figure 41 on page 60)

As an example, an Entry/Exit System using x4 photoelectric devices (see figure 46 on page 62)

DIP Switch Configuration* (refer to block 4.3 on page 22)

- MSSI Auto or Manual Reset SW1 = OFF (Manual)
- SSI Auto or Manual Reset SW2 = OFF (Manual)
or ON (Auto)
- One-Way Muting. SW3 = OFF (1-way)
- Two-/One-Channel EDM SW4 = OFF (2 CH)
- Backdoor Timer SW5&6 = OFF (30 s)
- Monitored Muting Lamp SW7 = OFF (Mon)
- Mute on Power-up SW8 = OFF (Disable)

*Both DIP switch Bank A and Bank B.

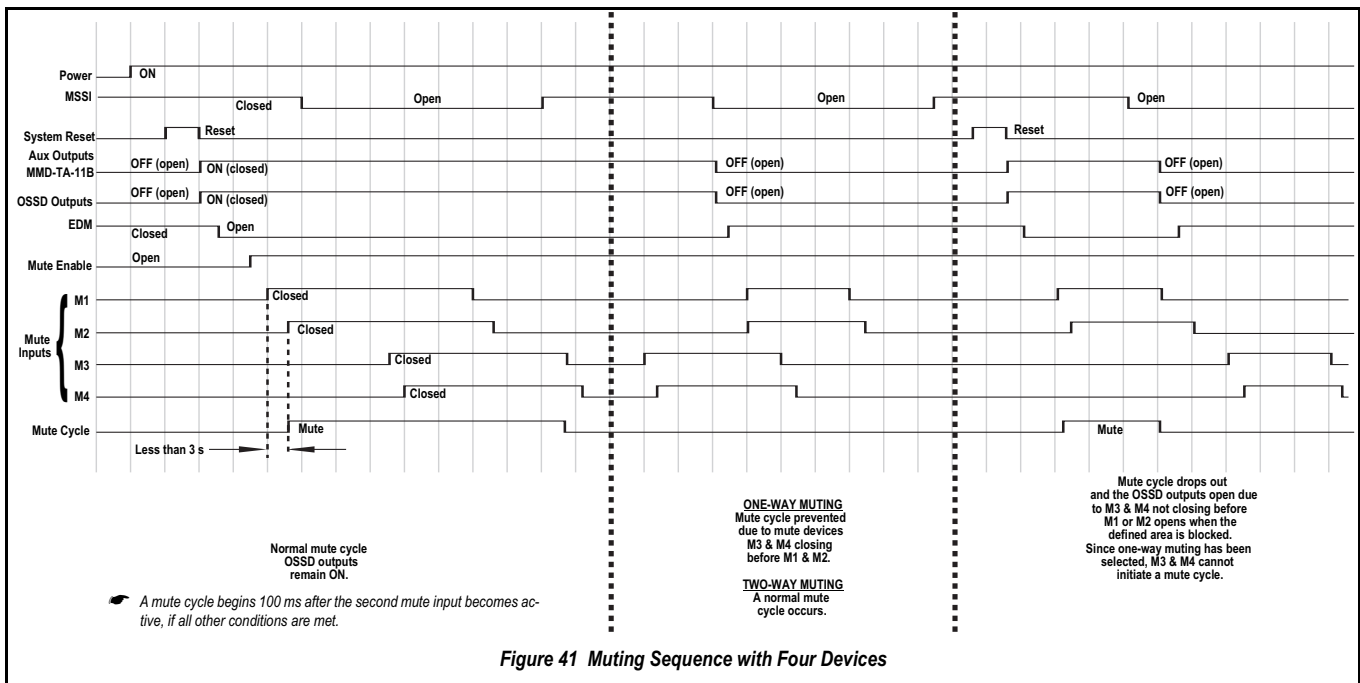

Figure 41 Muting Sequence with Four Devices

A3 TYPICAL MUTING APPLICATIONS

WARNING!

SAFETY CONSIDERATIONS

IT MUST NOT BE POSSIBLE FOR AN INDIVIDUAL TO BLOCK BOTH PHOTOELECTRIC BEAMS (DASHED DIAGONAL LINES IN figure 42 on page 61) AND INITIATE A MUTE CONDITION. CHECK THE INSTALLATION TO VERIFY THAT UNINTENTIONAL MUTING IS NOT POSSIBLE. THE CROSSING POINT OF THE PHOTOELECTRIC BEAMS MUST BE LOCATED IN THE HAZARDOUS AREA AND NOT BE ACCESSIBLE TO PERSONNEL (BY REACHING OVER, UNDER, THROUGH, OR AROUND). IT MUST NOT BE POSSIBLE FOR PERSONNEL TO WALK IN FRONT OF, BEHIND, OR NEXT TO THE MUTED OBJECT (FOR EXAMPLE, THE CARRIER BASKET) WITHOUT BEING DETECTED AND STOPPING THE HAZARDOUS MOTION. SUPPLEMENTARY GUARDING MUST BE USED TO PREVENT PERSONNEL FROM ENTERING THE HAZARDOUS AREA DURING A MUTE CONDITION.

Entry/Exit Applications

The muting devices must be placed to ensure that the points that trigger the mute's start and end are very close to the safety light screen's sensing field. This prevents personnel from following, or being pushed by, the object into the hazardous area without interrupting the safety light screen before the mute window opens or at the time the mute window closes.

When two pairs of opposed-mode photoelectrics are used as muting devices, as shown in figure 42 on page 61, the crossing point of the two sensing paths must be on the hazardous side of the safety light screen. The safety light screen is interrupted before any personnel are able to block both beams and mute the system. The devices should detect the material and not the pallet or the transport in order to delay an individual from riding into the hazardous area.

Further examples of different configurations for Entry/Exit applications are shown in figure 42 on page 61, figure 43 on page 61, figure 44 on page 61, figure 45 on page 62 and figure 46 on page 62.

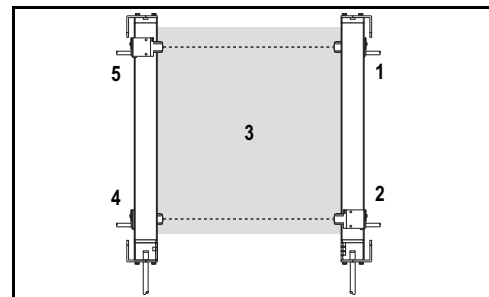

Index to figure

- 1. M1 (emitter not shown)
- 2. M2 (receiver)
- 3. Light screen defined area
- 4. M2 (emitter not shown)
- 5. M1 (receiver)

Figure 43 Horizontal Photoelectric Muting Devices Placed at Different Heights

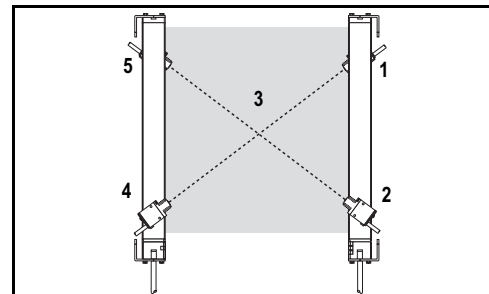

Index to figure

- 1. M1 (emitter not shown)
- 2. M2 (receiver)
- 3. Light screen defined area
- 4. M1 (receiver)
- 5. M2 (emitter not shown)

Figure 44 Photoelectric Muting Devices Placed Diagonally

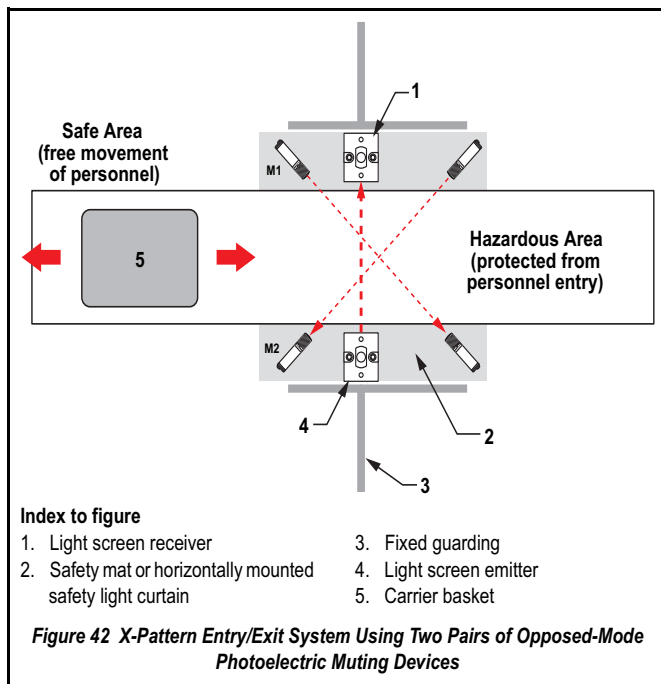

Index to figure

- 1. Light screen receiver
- 2. Safety mat or horizontally mounted safety light curtain
- 3. Fixed guarding
- 4. Light screen emitter
- 5. Carrier basket

Figure 42 X-Pattern Entry/Exit System Using Two Pairs of Opposed-Mode Photoelectric Muting Devices

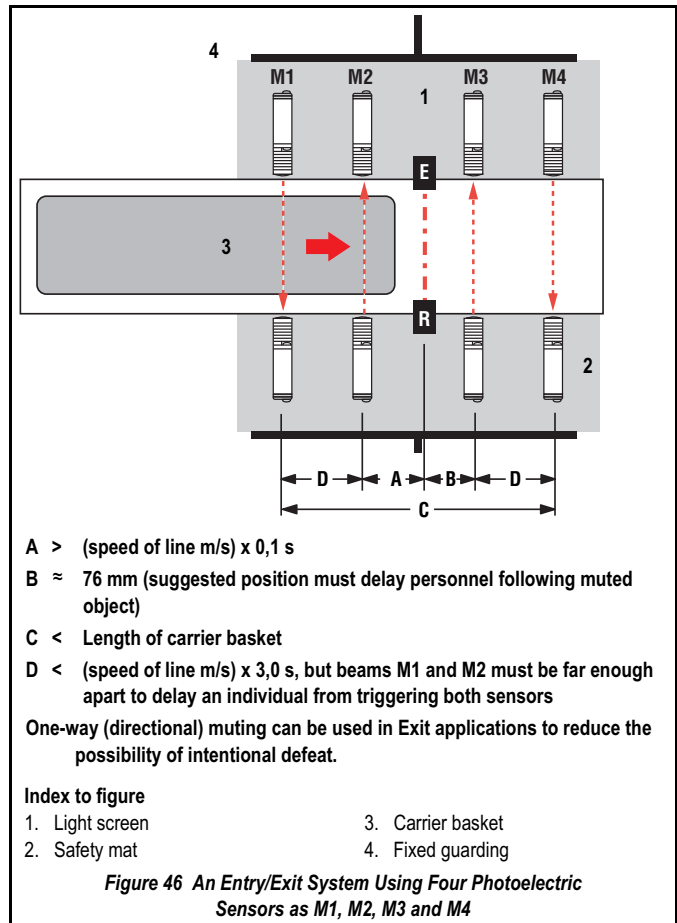
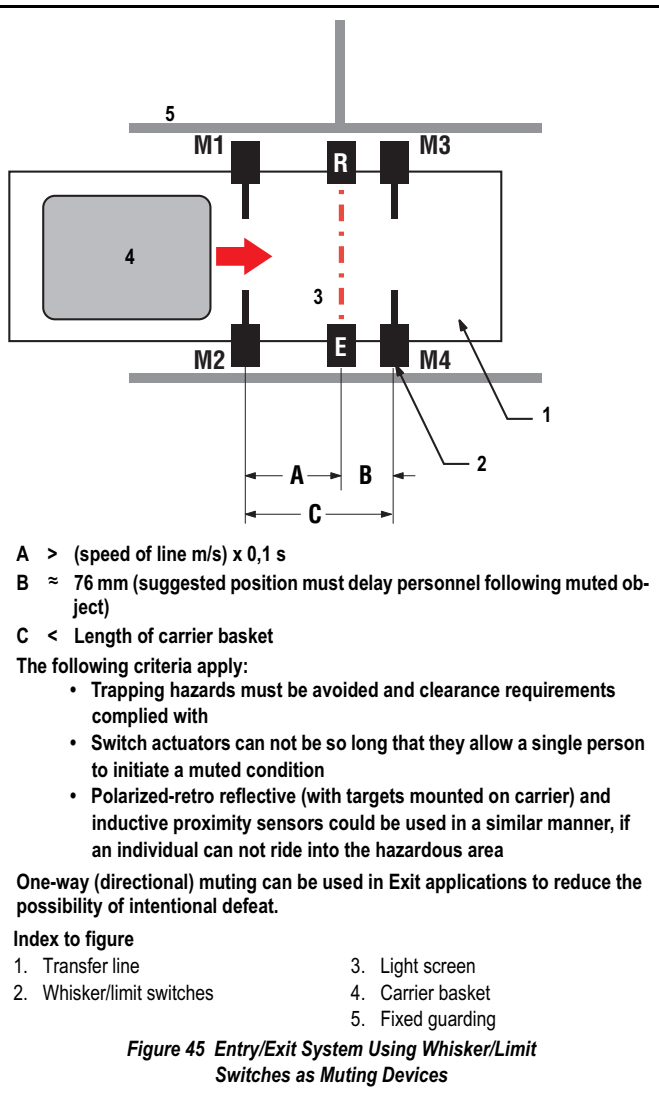

Robot Load/Unload Station Application

This Station muting application uses two independent safety light screen circuits, each with its own muting circuit and muting devices (for example; polarized-retro reflective photoelectrics). The application also includes run bars with two-hand control, auxiliary controls, and E-Stop. The two-hand control is provided at each station to safeguard the operator during the momentary clamping action of the fixture while the safety light screen is muted.

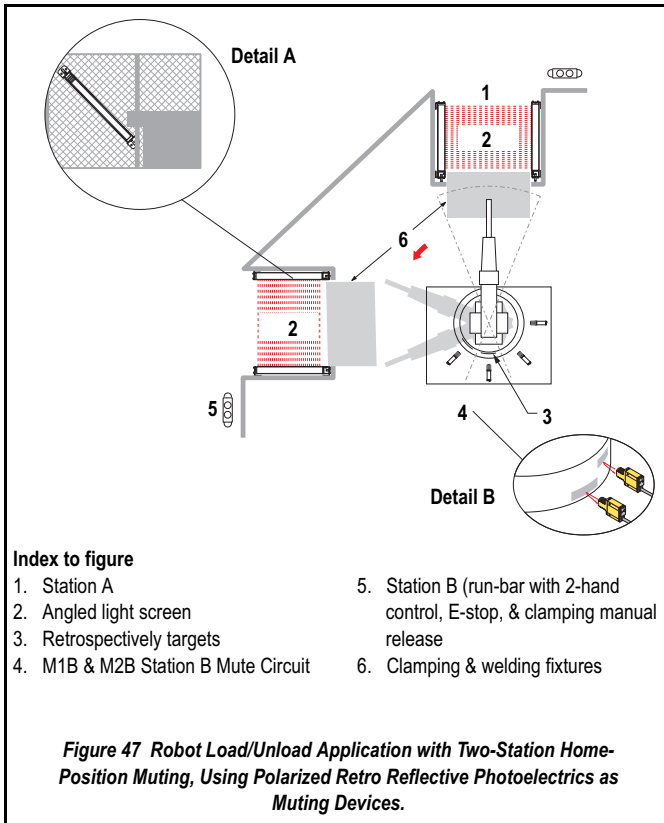

In figure 47 on page 63, the safety light screens are angled outwards (see Detail A). This provides proper MINIMUM SAFETY DISTANCE from the hazards created by the robot and the clamping/welding fixtures, while protecting against the possibility of Pass-through Hazards. In muting applications involving an operator, the operator must be continually detectable by the defined area. This ensures that if a hazard arises, causing the mute to end while the operator is present, the safety light screen immediately issues a stop command.

While the robot is at Station A, the light screen at Station B is muted (M1B and M2B are active), allowing the operator to load or unload without issuing a stop command to the robot. As the robot moves out of the A work envelope (as defined by Station B mute devices, see Detail B) the mute discontinues at Station B. If the operator is still within the protected area, a stop command is immediately issued. As the robot moves to the work envelope of Station B, the mute devices M1A and M2A activate and mute the safety light screen at Station A.

Intentionally Left Blank

A4 GLOSSARY & ABBREVIATIONS

List of Abbreviations

DIS	Development Information System
EDM	External Device Monitoring
FMEA	Failure Mode & Effects Analysis
FSD	Final Switching Device
IEC	International Electro-technical Commission
IP...	Ingress Protection (Class)
ISO	International Organisation for Standardisation
EN	Engineering Norm
ESPE	Electro-sensitive Protective Equipment
LED	Light Emitting Diode
ME	Mute Enable
ML	Mute Lamp
MSSI	Mutable Safety Stop Interfaces
MPCE	Machine Primary Control Element
OSSD	Output Signal Switching Device
PLC	Programmable Logic Controller
prEN	preliminary Engineering Norm
PSSD	Presence Sensing Safeguarding Device(s)
PSDI	Presence-Sensing-Device Initiation
QD	Quick Disconnect
SFI	Safety, Fibre Interlock (switch series)
SSI	Safety Stop Interface
VAC	Voltage Alternating Current
VDC	Voltage Direct Current

Glossary of Terms

Auto Power-Up: A safety light screen system feature which, when switched ON, enables the system to be powered up (and recover from a power interruption) without requiring a manual reset. When Auto Power-Up is ON, the safety light screen controller automatically begins internal diagnostics upon power-up, and automatically resets the system if it passes the diagnostic check. When Auto Power-up is OFF, a manual reset is required.

Blocked Condition: A safety light screen condition, when an opaque object of sufficient size blocks/interrupts one or more light screen beams. When a Blocked condition occurs, OSSD1 and OSSD2 outputs simultaneously turn off within the system response time.

Brake: A mechanism for stopping or preventing motion.

Clutch: A mechanism that, when engaged, transmits torque to impart motion from a driving member to a driven member.

Control Reliability: A method of ensuring the performance integrity of a control system. Control circuits are designed and constructed so that a single failure or fault within the system does not prevent the normal stopping action from being applied to the machine when required, or does not create unintended machine action, but does prevent initiation of successive machine action until the failure is corrected.

Defined Area: The "screen of light" generated between the emitter and receiver of a safety light screen system. When the defined area is interrupted by an opaque object of a specified cross section, a Trip or Latch condition results.

Designated Person: An individual identified and designated in writing, by the employer, as being appropriately trained to perform a specified checkout procedure. See [designated person as specified in block 1.9.1](#) (see also [qualified person on page 66](#)).

DIP (switch) Type of switch used for configuration settings.

Emitter: The light-emitting component of a safety light screen system, consisting of a row of synchronized modulated LEDs. The emitter, together with the receiver (placed opposite), creates a "screen of light" called the defined area.

E-stop Special switch push button positioned in strategic locations and used for shutting off electrical power and motion in an emergency to the machine.

External Device Monitoring (EDM): A means by which a safety device (such as a safety light screen) actively monitors the state (or status) of external devices that may be controlled by the safety device. A lockout of the safety device results if an unsafe state is detected in the external device. External device(s) may include, but are not limited to: MPCEs, mechanically linked relays/contactors, and safety modules.

Failure to Danger: A failure which delays or prevents a machine safety system from arresting dangerous machine motion.

False Proxing Sensor activation due to shiny or reflective surfaces.

Final Switching Device (FSD): The component of the machine's safety-related control system that interrupts the circuit to the machine primary control element (MPCE) when the output signal switching device (OSSD) goes to the OFF-state.

Fixed or Hard Guarding: Screens, bars, or other mechanical barriers affixed to the frame of the machine intended to prevent entry by personnel into the hazardous area(s) of a machine, while allowing the point of operation to be viewed. The maximum size of openings is determined by the applicable standard.

FMEA (Failure Mode and Effect Analysis): A testing procedure by which potential failure modes in a system are analysed to determine their results or effects on the system. Component failure modes that produce either no effect or a Lockout condition are permitted; failures which cause an unsafe condition (a failure to danger) are not. *Banner* safety products are extensively FMEA tested.

Forced-Guided Contacts: Relay contacts that are mechanically linked, so that when the relay coil is energized or de-energized, all of the linked contacts move together. If one set of contacts in the relay becomes immobilized, no other contact of the same relay is able to move. The function of forced-guided contacts is to enable the safety circuit to check the status of the relay. Forced-guided contacts are also known as “positive-guided contacts,” “captive contacts,” “locked contacts,” or “safety relays.”

Guarded Machine: The machine whose point of operation is guarded by the safety light screen system.

Hazardous Area: An area that poses an immediate or impending physical hazard.

Hazard Point: The closest reachable point of the hazardous area.

Internal Lockout: A Lockout condition that is due to an internal safety system problem. Generally, indicated by the red Status indicator LED (only) flashing. Requires the attention of a Qualified Person.

Key Reset (Manual Reset): a key-operated switch used to reset a safety light screen system to the ON state following a Lockout condition. Also refers to the act of using the switch to reset a safety system from a Latch condition.

Latch Condition: the response of the Safety Outputs (e.g., OSSDs) of a safety light screen system when an object equal to or greater than the diameter of the specified test piece enters the defined area. In a Latch condition, safety outputs simultaneously de-energize and open their contacts. The contacts are held (latched) open until the object is removed from the defined area and a manual reset is performed. A latching output is used most often in perimeter guarding applications (see [trip condition on page 67](#).)

Lockout Condition: A safety light screen system condition that is automatically attained in response to certain failure signals (an internal lockout). When a Lockout condition occurs, the safety light screen system’s safety outputs turn OFF, and a manual reset is required to return the system to RUN mode.

Machine Operator: An individual who performs production work and who controls operation of the machine.

Machine Primary Control Element (MPCE): An electrically-powered element, external to the safety system, which directly controls the machine’s normal operating motion in such a way that the element is last (in time) to operate when machine motion is either initiated or arrested.

Machine Response Time The time between the interruption by the DIN Muting Module OSSDs and the instant when the dangerous parts of the machine reach a safe state by being brought to rest.

Minimum Safety Distance: That distance, along the direction of approach, between the outermost position at which the appropriate test piece is just detected and the nearest dangerous machine part(s).

Muting: The automatic suspension of the safeguarding function of a safety device during a non-hazardous portion of the machine cycle.

OFF State: The state in which the output circuit is interrupted and does not permit the flow of current.

ON State: The state in which the output circuit is complete and permits the flow of current.

Output Signal Switching Device (OSSD): The safety outputs that are used to initiate a stop signal.

Pass-Through Hazard: A situation that may exist when personnel pass through a safeguard (at which point the hazard stops or is removed), and then continue into the guarded area. At this point the safeguard may not be able to prevent an unexpected start or restart of the machine with personnel within the guarded area.

Point of Operation: the location of a machine where material or a workpiece is positioned and a machine function is performed upon it.

Point-of-Operation Guarding: safeguards, such as hard guards or safety light screens, which are designed to protect personnel from hazardous machine motion when close to the machine’s point of operation.

Positive Opening Switch: Term used with reference to E-Stops. A mechanical force applied to such a button (or switch) is transmitted directly to the contacts, forcing them open without the use of springs. This ensures that the switch contacts open whenever the switch is activated even if a contact has welded closed.

Presence-Sensing-Device Initiation (PSDI): An application in which a presence-sensing device is used to actually start the cycle of a machine. In a typical situation, an operator manually positions a part in the machine for the operation. When the operator moves out of the hazardous area, the presence-sensing device starts the machine (no start switch is used). The machine cycle runs to completion, and the operator can then insert a new part and start another cycle. The presence-sensing device continually safeguards the machine. Single break mode is used when the part is automatically ejected after the machine operation. Double break mode is used when the part is both inserted (to begin the operation) and removed (after the operation) by the operator. *Banner* DIN Muting Module may not be used as PSDI devices on mechanical power presses.

Qualified Person: An individual who, by possession of a recognized degree or certificate of professional training, or by extensive knowledge, training, and experience, has successfully demonstrated the ability to solve problems relating to the subject matter and work. See [qualified person as specified in block 1.9.2 on page 3](#) (see also [designated person on page 65](#)).

Receiver: the light-receiving component of a safety light screen system, consisting of a row of synchronized photo transistors. The receiver, together with the emitter (placed opposite), creates a “screen of light” called the defined area.

Remote Display: Optional component used for remotely displaying a duplicate version of the information that is displayed on the DIN Muting Module itself.

Reset: The use of a manually operated switch to restore the safety outputs to the ON state from a lockout or a Latch condition.

Response Time: The time between the physical initiation of the safety device and the machine coming to a stop or the risk being removed.

Self-Checking (Circuitry): a circuit with the capability to electronically verify that all of its own critical circuit components, along with their redundant backups, are operating properly. *Banner* safety light screen systems and safety modules are self-checking.

Simultaneity Requirement: The requirement for a pair of electrical devices to be activated within at least 3 seconds of each other.

Specified Test Piece: an opaque object of sufficient size used to block a light beam to test the operation of a safety light screen system. When inserted into any part of the defined area, it places a system into a Trip or Latch condition. *Banner* supplies specified test pieces with each system. See also Minimum Object Sensitivity.

Supplemental Guarding: additional safeguarding device(s) or hard guarding, used to prevent a person from reaching over, under, through or around the primary safeguard or otherwise accessing the guarded hazard.

Test Piece: an opaque object of sufficient size used to block a light beam to test the operation of a safety light screen system.

Trip Condition: the response of the safety outputs (e.g., OSSDs) of a safety light screen system when an object equal to or greater than the diameter of the specified test piece enters the defined area. In a Trip condition, the OSSDs simultaneously de-energize. A Trip condition clears (resets) automatically when the object is removed from the defined area. (See also [Latch Condition on page 66](#))

TUV (Technischer Überwachungsverein): independent testing and certification organization providing EMC and product safety testing, certification, and quality management systems registration.

UL (Underwriters Laboratory): a third-party organization that tests products for compliance with appropriate standards, electrical codes, and safety codes. Compliance is indicated by the UL listing mark on the product.

Intentionally Left Blank

A5 CUSTOMER INFORMATION

The following is a list of addresses for *Banner* Representatives and Distributors in Europe:



CORPORATE OFFICES:

Banner Engineering Europe
Park Lane, Culliganlaan 2F
1831 Diegem,
Belgium

Tel.: +32 2 456 07 80

Fax: +32 2 456 07 89

e-mail: mail@bannereurope.com

<http://www.bannereurope.com>

Banner Engineering GmbH

Martin-Schmeißer-Weg 11
44227 Dortmund

Tel.: + 49 (0) 231 963 37 30

Fax: + 49 (0) 231 963 39 38

e-mail: info@bannerengineering.de

<http://www.bannerengineering.de>



AUSTRIA

Intermax GmbH

Josef-Moser-Gasse 1
A-1170 Vienna

Tel.: +431 48 615870

Fax: +431 48 6158723

e-mail: imax.office@intermax.at

<http://www.intermax.at>



BELGIUM

MULTIPROX N.V.

Lion d'Orweg, 12
B-9300 Aalst

Tel.: +32 53 766 566

Fax: +32 53 783 977

e-mail: mail@multiprox.be

<http://www.multiprox.be>



BULGARIA

Sensomat Ltd.

VH V, App 11
Dr. Ivan Penakov Str. 15
BG-9300 Dobrich

Tel.: +359 58 603 023

Fax: +359 58 603 033

e-mail: info@sensomat.info

<http://www.sensomat.info>



CZECH REPUBLIC

Turck s.r.o.

Hradecká 1151
CZ-50003 Hradec Králové 3

Tel.: +420 495 518 766

Fax: +420 495 518 767

e-mail: turck@turck.cz

<http://www.turck.cz>



DENMARK

Hans Folsgaard AS

Ejby Industrivej 30
Dk-2600 Glostrup

Tel.: +45 43 20 86 00

Fax: +45 43 96 88 55

e-mail: hf@hf.net

<http://www.hf.net>



ESTONIA

Osaühing « System Test »

Pirita tee 20
EE-10127 Tallinn
Estonia

Tel.: +372 6 405 423

Fax: +372 6 405 422

e-mail: systemtest@systemtest.ee



FINLAND

Sarlin Oy Ab

P.O. Box 750
SF-00101 Helsinki 10

Tel.: +358 9 50 44 41

Fax: +358 9 56 33 227

e-mail: sales.automation@sarlin.com

<http://www.sarlin.com>



FRANCE

Turck Banner S.A.S.

3, Rue de Courtalin
Magny - Le - Hongre
77703 Marne - La - Vallée Cedex 4

Tel.: +33 1 60 43 60 70

Fax: +33 1 60 43 10 18

e-mail: info@turckBanner.fr

<http://www.turckBanner.fr>



GERMANY

Hans Turck GmbH & Co KG

Witzlebenstrasse 7
45472 Mülheim an der Ruhr

Tel.: +49 208 49 520

Fax: +49 208 49 52 264

e-mail: turckmh@mail.turck-globe.de

<http://www.turck.com>



GREECE

2KAPPA LTD

Sofokli Venizelou 13, 54628 Menemeni

Tel: 00 30 23 10 77 55 10

Fax: 00 30 23 10 77 55 14-15

email: 2kappa@pel.forthnet.gr



HUNGARY

Turck Hungary Kft.

Könyves Kalman Krt. 76
H-1087 Budapest

Tel.: +36 1 477-0740 or 36-1-313-8221

Fax: +36 1 477-0741

e-mail: turck@turck.hu

<http://www.turck.hu>



ICELAND

K M Stáhl ehf.

Bíldshöfða 16
110 Reykjavik

Tel.: +354 56 78 939

Fax: +354 56 78-938

e-mail: kalli@kmstal.is



IRELAND

Tektron

Tramore House
Tramore Road
Cork

Tel.: +353 (0)21-431 33 31

Fax: +353 (0)21-431 33 71

e-mail: sales@tektron.ie

<http://www.tektron.ie>



ITALY

Turck Banner s.r.l.

Via Adamello, 9
20010 Bareggio
Milano

Tel.: +390 2 90 36 42 91

Fax: +390 2 90 36 48 38

e-mail: info@turckBanner.it

<http://www.turckBanner.it>



LATVIA

LASMA Ltd.

Aizkraukles 21-111
LV-1006 Riga

Tel.: +371 754 5217

Fax: +371 754 5217

e-mail: inga@lasma.lv

**LITHUANIA****Hidroteka**

Büro: Taikos 76-4
 LT-3031 Kaunas
 Post: P.O. Box 572
 LT-3028 Kaunas
 Tel.: +370 37 352195
 Fax: +370 37 351952
 e-mail: hidroteka@post.sonexco.com

**LUXEMBOURG****Sogel SA 1**

7, Rue de l'Industrie
 8399 Windhof
 Luxembourg
 Tel.: +352 40 05 05 331
 Fax: +352 40 05 05 305
 e-mail: sogel@sogel.lu

**NETHERLANDS/HOLLAND****Turck B.V.**

Ruiterlaan 7
 NL-8019 BN Zwolle
 Tel.: +31 38 42 27 750
 Fax: +31 38 42 27 451
 e-mail: info@turck.nl
<http://www.turck.nl>

**NORWAY****Danyko A.S.**

P.O. Box 48
 N-4891 Grimstad
 Tel.: +47 37 04 02 88
 Fax: +47 37 04 14 26
 e-mail: danyko@hf.net
<http://www.danyko.no>

**POLAND****Turck Sp. z o.o.**

ul Zeromskiego 1
 PL-50 053 Opole
 Tel.: +48-77 443 48 00
 Fax: +48-77 443 48 01
 e-mail: turck@turck.pl
<http://www.turck.pl>

**PORTUGAL****Salmon & Cia Lda.**

Rua Cova da Moura, 2-6°
 1399-033 Lisboa
 Tel.: +351 21 39 20 130
 Fax: +351 21 39 20 189
 e-mail: div8.salmon@mail.telepac.pt

**ROMANIA****TURCK Automation Romania SRL**

Str. Iuliu Tetrat nr. 18, Sector 1
 RO-011914 Bucharest
 Tel: +40 21 230 02 79 or 230 05 94
 Fax: +40 21 231 40 87
 e-mail: info@turck.ro
<http://www.turck.ro>

**RUSSIA AND CIS****Turck Office Minsk**

ul. Engelsa, 30
 BY-220030 Minsk
 Republic of Belarus
 Tel.: +375 172 105957
 Fax: +375 172 275313
 e-mail: turck@infonet.by
<http://www.turck.by>

Turck Office Moscow

Volokolamskoe shosse 1 office 606A
 125080 Moscow
 Tel.: +7 095 105 00 54
 Fax: +7 095 158 95 72
 e-mail: turck@turck.ru

**SLOVAK REPUBLIC****MARPEX s.r.o.**

Sportovcov 672
 018 41 Dubnica nad Váhom
 Tel.: +421 42 4426987
 Fax: +421 42 4426986
 e-mail: marpex@marpex.sk

**SLOVENIA****Tipteh d.o.o**

CESTA V GORICE 40
 SLO-1111 Ljubljana
 Tel.: +386 1 200 51 50
 Fax: +386 1 200 51 51
 e-mail: info@tipteh.si

**SPAIN****Elion, S.A.**

Farell, 5 - 08014 Barcelona
 Tel.: + 932 982 035
 Fax: + 934 314 133
 e-mail: elion@elion.es
<http://www.elion.es>

**SWEDEN****HF Sverige AB**

Stockholm :
 Kanalvägen 10C
 SE-194 61 Upplands Väsby
 Tel.: +46 8 555 409 85
 Fax: +46 8 590 717 81
 e-mail: hf.sverige@hf.net
<http://www.hf.net>
 Båstad :
 Tel.: +46 431 755 60
 Fax: +46 431 755 61
 e-mail: hf@hf.net
<http://www.hf.net>
 Malmö :
 Tel.: +46 040 611 96 70
 Fax: +46 040 611 96 85
 e-mail: hf@hf.net
<http://www.hf.net>

**SWITZERLAND****Bachofen AG**

Ackerstrasse 42
 8610 Uster
 Tel.: + 41 44 944 11 11
 Fax: + 41 44 944 12 33
 e-mail: info@bachofen.ch
<http://www.bachofen.ch>

**TURKEY****Dacel Muhendislik Elektrik,**

Elektronik, San. Ve Tic. Ltd.
 Perpa Elektrokent Is Merkezi
 A Blok Kat 2 No:38
 Okmedani/Istanbul
 TURKIYE
 Tel: 00 90 212 210 76 46
 Fax: 00 90 212 220 50 45
 e-mail: Özer Özkurt -ozkurt@dacel.net

Gökhan Elektrik Malzemeİri San Tic Ltd. Sti

Perpa Elektrokent Ticaret Merkezi A Blok Kat 8
 No : 694
 80270 Okmeydani - ISTANBUL
 Tel.: +90 212 2213236
 Fax: +90 212 2213240
 e-mail: gokhan@gokhanelektrik.com
<http://www.gokhanelektrik.com>

**UNITED KINGDOM****Turck Banner Limited**

Blenheim House, Hurricane Way,
 Wickford,
 Essex, SS11 8YT
 Tel: +44 (0)1268 578888
 Fax: +44 (0)1268 763648
 e-mail: info@turckBanner.co.uk
<http://www.turckBanner.co.uk>