

Sure Cross® Gateway Module for a Wireless Q45 Temperature/Humidity Sensor



Datasheet



Sure Cross® embeddable board radio modules were specifically designed for the needs of industrial users to provide connectivity where traditional wired connections are not possible or cost prohibitive. Wireless networks are formed around a Gateway, which acts as the wireless network master device, and one or more Nodes. Sure Cross embeddable board radio modules communicate with all Sure Cross radios.

- Wireless industrial I/O device with two PNP discrete inputs and two analog outputs
- 10 to 30 V dc power input
- Two PNP inputs are mapped directly to the Wireless Q45 Sensor Node's red/green alarm indicator LED
- DIP switches allow the user to select from three scaled temperature ranges for the analog outputs
- Site Survey analyzes the network's signal strength and reliability and conveys the results using the two-color LED
- Frequency Hopping Spread Spectrum (FHSS) technology and Time Division Multiple Access (TDMA) control architecture ensure reliable data delivery within the unlicensed Industrial, Scientific, and Medical (ISM) band
- Transceivers provide bidirectional communication between the Gateway and Node, including fully acknowledged data transmission
- Lost RF links are detected and relevant outputs set to user-defined conditions

For additional information, updated documentation, and accessories, refer to Banner Engineering's website, www.bannerengineering.com/surecross.

Models	Frequency	Inputs and Outputs
DX80G2M6-B2T	2.4 GHz ISM Band	Inputs: Two PNP discrete Outputs: Two analog (4 to 20 mA)



WARNING: Not To Be Used for Personnel Protection

Never use this device as a sensing device for personnel protection. Doing so could lead to serious injury or death. This device does not include the self-checking redundant circuitry necessary to allow its use in personnel safety applications. A sensor failure or malfunction can cause either an energized or de-energized sensor output condition.



CAUTION: Electrostatic Discharge (ESD)

ESD Sensitive Device. Use proper handling procedures to prevent ESD damage to these devices. The module does not contain any specific ESD protection beyond the structures contained in its integrated circuits. Proper handling procedures should include leaving devices in their anti-static packaging until ready for use; wearing anti-static wrist straps; and assembling units on a grounded, static-dissipative surface.

Setting Up and Installing a Wireless Q45

To set up and install your Gateway and Wireless Q45, follow these steps.

1. Configure the Gateway and Wireless Q45 I/O Mapping
2. Wire the Gateway's I/O
3. Apply power to the Gateway
4. Bind the Wireless Q45 to the Gateway
5. Observe the LED behavior to verify the devices are communicating to each other
6. Conduct a Site Survey between the Gateway and the Wireless Q45
7. Install your devices



Configure the DIP Switches

Before making any changes to the DIP switch positions, disconnect the power. DIP switch changes will not be recognized if power isn't cycled to the device.

For parameters not set via DIP switches, use the User Configuration Tool (UCT) to make configuration changes. For parameters set using the DIP switches, the DIP switch positions override any changes made using the User Configuration Tool.

DIP Switch Settings

Transmit Power

The transmit power for 2.4 GHz is fixed at 100 mW EIRP (18 dBm), making the 2.4 GHz Performance models automatically compatible with the DX80 2.4 GHz models.

Modbus/UCT Configured or DIP Switch Configured

In Modbus/UCT Configured mode, the device parameters are changed using the User Configuration Tool (UCT) or a Modbus command. All DIP switch positions are ignored. In DIP Switch Configured mode, use the DIP switches to configure the parameters listed in the table. By default, this Gateway uses the DIP switches to configure the device.

DIP Switch	
2	Modbus/UCT Configured or DIP Switch Configured
OFF *	DIP switch configured
ON	Modbus or UCT configured (DIP switches 3–8 are ignored)

I/O Mapping for one Wireless Q45 Temperature/Humidity Sensor to a DX80G2M6-B2T Gateway

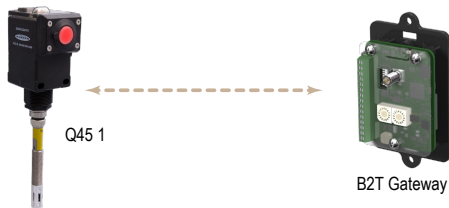

DIP Switches		
5		I/O Mapping
OFF *		Gateway's discrete inputs mapped to the Wireless Q45 Sensor's light outputs Gateway's Discrete IN 1 → Q45's Discrete OUT 1 (red light) Gateway's Discrete IN 2 → Q45's Discrete OUT 2 (green light)
ON		No mapping to the Wireless Q45's light outputs

DIP Switches		
6	7	Temperature Ranges
OFF *	OFF *	Wireless Q45's -40 °C to 85 °C temperature reading to the Gateway's 4 to 20 mA output Q45's Temperature °C → Gateway's Analog OUT 1 Q45's Relative Humidity → Gateway's Analog OUT 2
OFF	ON	Wireless Q45's 0 °C to 85 °C temperature reading to the Gateway's 4 to 20 mA output Q45's Temperature °C → Gateway's Analog OUT 1 Q45's Relative Humidity → Gateway's Analog OUT 2
ON	OFF	Wireless Q45's -20 °C to 60 °C temperature reading to the Gateway's 4 to 20 mA output Q45's Temperature °C → Gateway's Analog OUT 1 Q45's Relative Humidity → Gateway's Analog OUT 2
ON	ON	Custom setting

DIP switches 3, 4, and 8 are not used at this time.

Wire the Gateway's I/O and Apply Power

Refer to the Class I Division 2/Zone 2 control drawings (p/n 143086) for wiring specifications or limitations.

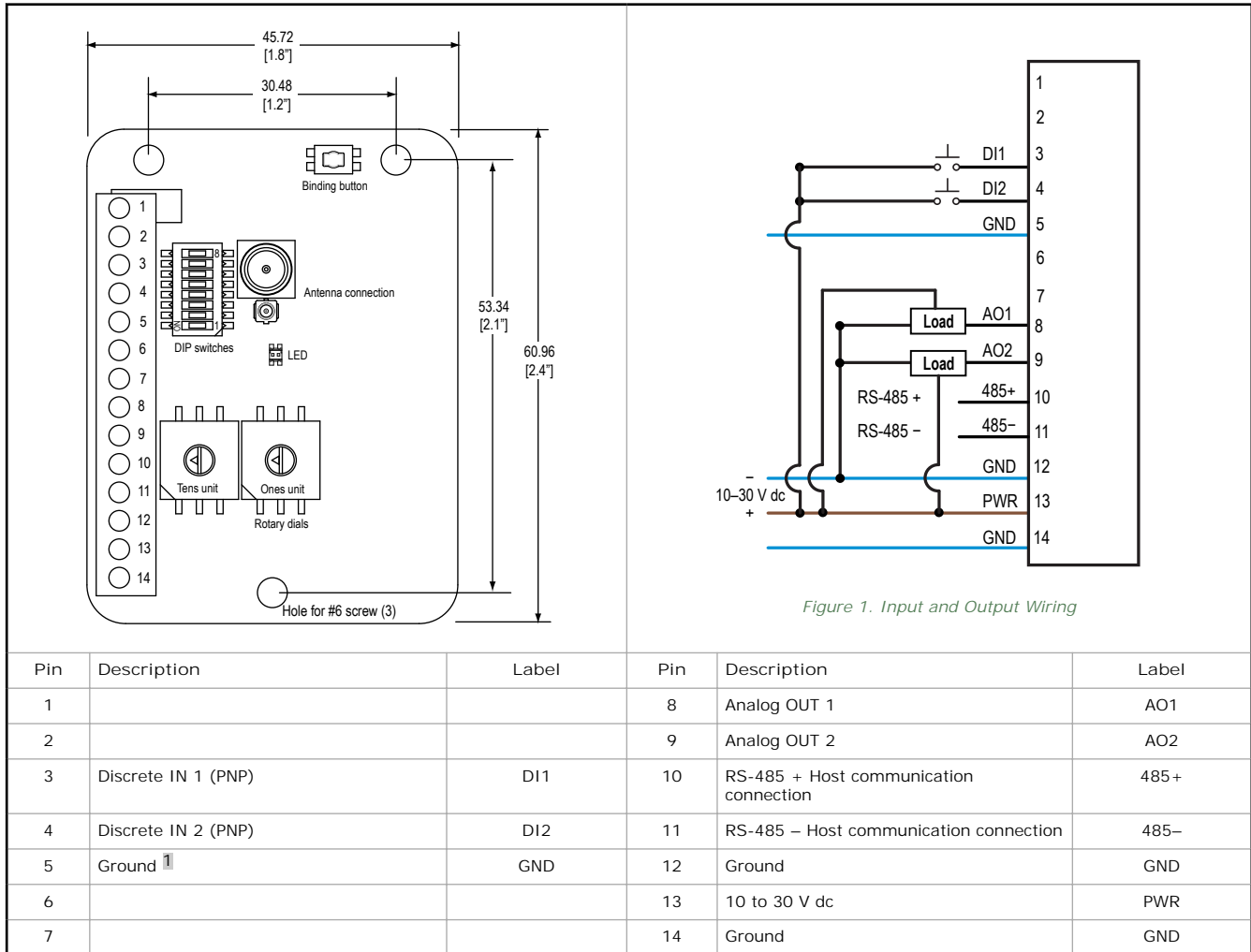

Bind the Wireless Temperature/Humidity Q45 to the B2T Gateway and Assign the Node Address

Before beginning the binding procedure, apply power to all the devices.

1. Enter binding mode on the Gateway by triple-clicking the button. The green and red LED flashes.
2. Assign the Q45 a Node address or 01 using the Gateway's rotary dials. Set the left dial to 0 and the right dial to 1.
3. Loosen the clamp plate on the top of the Wireless Q45 and lift the cover.
4. Enter binding mode on the Wireless Q45 by triple-clicking the button. The red and green LEDs flash alternately and the sensor searches for a Gateway in binding mode. After the Q45 is bound, the LEDs stay solid momentarily, then they flash together four times. The Q45 exits binding mode.
5. After binding the Wireless Temperature/Humidity Q45, exit binding mode on the Gateway by double-clicking the button.

LED Behavior for the Gateways

Verify all devices are communicating properly. The radios and antennas must be a minimum distance apart to function properly. Recommended minimum distances are:

900 MHz 150 mW radios: 6 feet

¹ The three ground connections are tied together internally.

900 MHz 1 Watt radios: 15 feet

2.4 GHz 65 mW radios: 1 foot

LED (Bi-color)	Gateway Status
Solid green	Power ON
Green and red flashing alternately	Binding mode
Flashing red	Device Error
Green and red flashing together, looks amber	Modbus Communication Active
Flashing red	Modbus Communication Error
Solid red	Gateway is trying to conduct a Site Survey with a Node that doesn't exist
Green and red solid together, looks amber)	No radio communication detected

For Gateway and Ethernet Bridge systems, active Modbus communication refers to the communication between the Gateway and the Ethernet Bridge. For Gateway-only systems, the Modbus communication LEDs refer to the communication between the Gateway and its host system (if applicable).

Conduct a Site Survey from a Gateway Board Model

Conducting a Site Survey, also known as an RSSI (Radio Signal Strength Indication), analyzes the radio communications link between the Gateway and any Node within the network by analyzing the radio signal strength of received data packets and reporting the number of missed packets that required a retry.

Perform a Site Survey before permanently installing the radio network to ensure reliable communication. Only the Gateway can initiate a Site Survey, and the Site Survey analyzes the radio communications link with one Node at a time. Follow these steps to conduct a Site Survey from the board module Gateway.

- To start the Site Survey, set the Gateway's rotary dials to the Node address you'd like to conduct a Site Survey with. For example, to analyze the signal strength between this Gateway and Node 02, rotate the left rotary dial to 0 and the right rotary dial to 2. The Site Survey automatically begins running. If there is a device at address 02, the LED flashes amber. If there is no device at address 02, the LED is solid red. The amber LED flashes at varying rates to indicate the signal strength.
- To exit the Site Survey, set the Gateway's rotary dials to 00. Otherwise, after 15 minutes the Gateway automatically exits Site Survey mode. The LED flashes green to indicate the Gateway is in standard operating mode.

The amber LED flashes at specific rates to indicate the Site Survey results. Each signal strength represents the majority of the data packets being received at that signal strength. For example, a strong signal strength indicates the majority of the data packets were received at a strong signal, but a few many have been received at a good or weak signal strength.

- Eight flashes per second: Very strong signal strength
- Four flashes per second: Strong signal strength
- Two flashes per second: Good signal strength
- One flash per second: Weak signal strength
- Solid amber LED: No radio communication detected

Modbus Register Table

I/O #	Modbus Holding Register		I/O Type	I/O Range		Holding Register Representation	
	Gateway	Any Node		Min.	Max.	Min. (Dec.)	Max. (Dec.)
1	1	1 + (Node# × 16)	Discrete IN 1	0	1	0	1
2	2	2 + (Node# × 16)	Discrete IN 2	0	1	0	1
		...					
7	7	7 + (Node# × 16)	Reserved				
8	8	8 + (Node# × 16)	Device Message				
		...					
11	11	11 + (Node# × 16)	Analog OUT 1	4 mA	20 mA	0	65535
12	12	12 + (Node# × 16)	Analog OUT 2	4 mA	20 mA	0	65535

I/O #	Modbus Holding Register		I/O Type	I/O Range		Holding Register Representation	
	Gateway	Any Node		Min.	Max.	Min. (Dec.)	Max. (Dec.)
		...					
15	15	15 + (Node# × 16)	Control Message				
16	16	16 + (Node# × 16)	Reserved				

Specifications

Radio Range

2.4 GHz, 65 mW: Up to 3.2 km (2 miles)²

Minimum Separation Distance

2.4 GHz, 65 mW: 0.3 m (1 ft)

Radio Transmit Power

2.4 GHz, 65 mW: 18 dBm (65 mW) conducted, less than or equal to 20 dBm (100 mW) EIRP

2.4 GHz Compliance

FCC ID UE300DX80-2400 - This device complies with FCC Part 15, Subpart C, 15.247
 ETSI EN 300 328 V1.8.1 (2012-06)
 IC: 7044A-DX8024

Spread Spectrum Technology

FHSS (Frequency Hopping Spread Spectrum)

Antenna Connection

Ext. Reverse Polarity SMA, 50 Ohms
 Max Tightening Torque: 0.45 N·m (4 lbf·in)

Interface

Indicators: One bi-color LED
 Buttons: One

Wiring Access

Terminal block

Radiated Immunity

10 V/m (EN 61000-4-3)

Supply Voltage

10 to 30 V dc (Outside the USA: 12 to 24 V dc, ±10%).³

Discrete Input

Two, sourcing
 Rating: 3 mA max current at 30 V dc
 Sample Rate: 62.5 milliseconds
 Report Rate: On change of state
 ON Condition (PNP): Greater than 8 V
 OFF Condition (PNP): Less than 5 V

Analog Output

Two, 4 to 20 mA
 Update rate: 125 milliseconds
 Accuracy: 0.1% of full scale +0.01% per °C
 Resolution: 12-bit

Operating Conditions

-40 °C to +85 °C (-40 °F to +185 °F)⁴
 95% maximum relative humidity (non-condensing)

Certifications



CSA: Class I Division 2 Groups ABCD, Class I Zone 2 AEx/Ex nA II T4
 — Certificate: 1921239



ATEX: II 3 G Ex nA IIC T4 Gc (Group IIC Zone 2) — Certificate LCIE
 10 ATEX 1012 X

Refer to the Class I Division 2/Zone 2 control drawings (p/n 143086) for wiring specifications or limitations. All battery-powered devices must only use the lithium battery manufactured by Xeno, model XL-205F.

Accessories for the Board Models

<p>BWA-HW-034</p> <ul style="list-style-type: none"> DIN rail clip, black plastic 	<p>BWA-HW-030</p> <ul style="list-style-type: none"> u.FL to RP-SMA adapter cable 
--	--

² Radio range is with the 2 dB antenna that ships with the product. High-gain antennas are available, but the range depends on the environment and line of sight. Always verify your wireless network's range by performing a Site Survey.

³ For European applications, power this device from a Limited Power Source as defined in EN 60950-1.

⁴ Operating the devices at the maximum operating conditions for extended periods can shorten the life of the device.

MultiHop M-HBx and Performance PBx Models Mounted on the Base

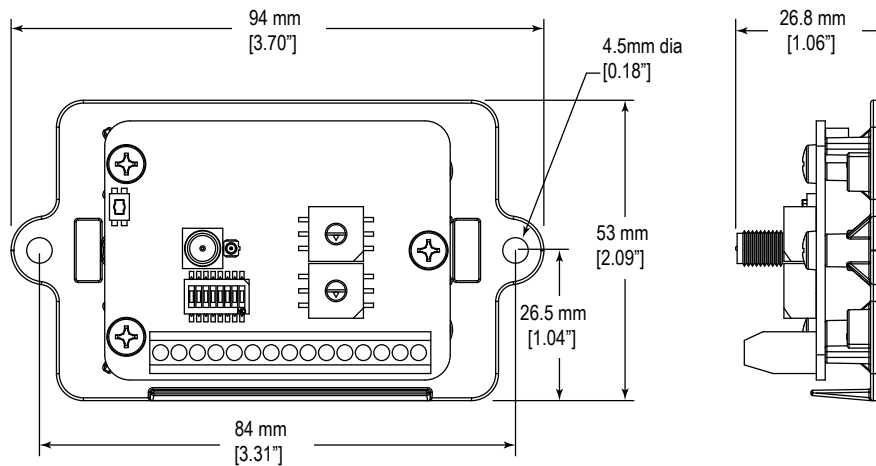

Figure 2. Most MultiHop M-HBx and Performance PBx models ship from the factory mounted on a plastic base.

Warnings

Install and properly ground a qualified surge suppressor when installing a remote antenna system. Remote antenna configurations installed without surge suppressors invalidate the manufacturer's warranty. Keep the ground wire as short as possible and make all ground connections to a single-point ground system to ensure no ground loops are created. No surge suppressor can absorb all lightning strikes; do not touch the Sure Cross® device or any equipment connected to the Sure Cross device during a thunderstorm.

Exporting Sure Cross® Radios. It is our intent to fully comply with all national and regional regulations regarding radio frequency emissions. Customers who want to re-export this product to a country other than that to which it was sold must ensure the device is approved in the destination country. A list of approved countries appears in the *Radio Certifications* section of the product manual. The Sure Cross wireless products were certified for use in these countries using the antenna that ships with the product. When using other antennas, verify you are not exceeding the transmit power levels allowed by local governing agencies. Consult with Banner Engineering Corp. if the destination country is not on this list.

Any misuse, abuse, or improper application or installation of this product or use of the product for personal protection applications when the product is identified as not intended for such purposes will void the product warranty. Any modifications to this product without prior express approval by Banner Engineering Corp will void the product warranties. All specifications published in this document are subject to change; Banner reserves the right to modify product specifications or update documentation at any time. For the most recent version of any documentation, refer to: www.bannerengineering.com. © Banner Engineering Corp. All rights reserved.

Banner Engineering Corp. Limited Warranty

Banner Engineering Corp. warrants its products to be free from defects in material and workmanship for one year following the date of shipment. Banner Engineering Corp. will repair or replace, free of charge, any product of its manufacture which, at the time it is returned to the factory, is found to have been defective during the warranty period. This warranty does not cover damage or liability for misuse, abuse, or the improper application or installation of the Banner product.

THIS LIMITED WARRANTY IS EXCLUSIVE AND IN LIEU OF ALL OTHER WARRANTIES WHETHER EXPRESS OR IMPLIED (INCLUDING, WITHOUT LIMITATION, ANY WARRANTY OF MERCHANTABILITY OR FITNESS FOR A PARTICULAR PURPOSE), AND WHETHER ARISING UNDER COURSE OF PERFORMANCE, COURSE OF DEALING OR TRADE USAGE.

This Warranty is exclusive and limited to repair or, at the discretion of Banner Engineering Corp., replacement. IN NO EVENT SHALL BANNER ENGINEERING CORP. BE LIABLE TO BUYER OR ANY OTHER PERSON OR ENTITY FOR ANY EXTRA COSTS, EXPENSES, LOSSES, LOSS OF PROFITS, OR ANY INCIDENTAL, CONSEQUENTIAL OR SPECIAL DAMAGES RESULTING FROM ANY PRODUCT DEFECT OR FROM THE USE OR INABILITY TO USE THE PRODUCT, WHETHER ARISING IN CONTRACT OR WARRANTY, STATUTE, TORT, STRICT LIABILITY, NEGLIGENCE, OR OTHERWISE.

Banner Engineering Corp. reserves the right to change, modify or improve the design of the product without assuming any obligations or liabilities relating to any product previously manufactured by Banner Engineering Corp.