

The Mono Ball Valve design is used for direct shut off of flow like any Ball Valve. The difference is the compact design and light weight.

The Valve can be used in conjunction with other valves in series to allow for a safer shut off creating a double block for safety. This can also be used with a Double Block and Bleed valve where safety shut off is of great concern but still allows for a small profile.



## Features and Benefits

- Small, Thin design and light weight
- Design allows you to combine with other valves in series for safe shut off
- Sizes from 1/2" through 2" and from ANSI 150# up to ANSI 2500# Class Flanges
- 10mm Through Bore

## Product Availability

This valve is available in 316 SS, Carbon Steel, Hastelloy C, Monel and other materials upon request. (NACE material is also available)

## Application

On/Off Flow control, Used in conjunction with another valve of Double Block & Bleed Valve in Upstream Oil & Gas Applications and used in combination with another valve for safety shut off where space is at a minimum.

## Ratings

Body is rated to 10,000 psig @ 100°F (689,5 Bar @ 38°C) with Carbon Peek Seats or 6250 psig @ 100°F (431 Bar @ 38°C) with standard Peek Seats. Valves are rated based on ANSI B16.34 Flange Ratings for Class 150# through Class 2500# Flanges

## Flow Schematic



## Dimensions

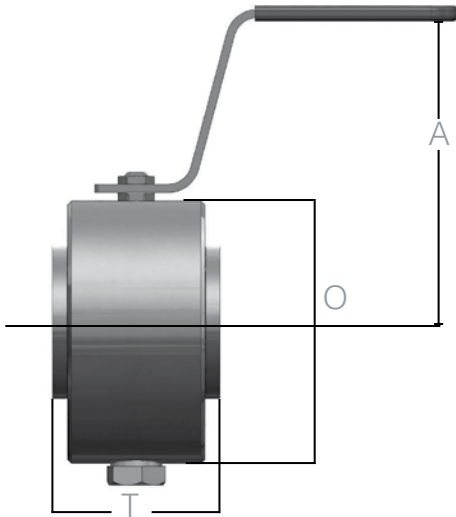

Dimensions				
Nominal Pipe Size (NPS)	Outside Dia. of Flange, O	A	T, RF	T, RTJ
1/2 150#	3.50 (88,9)	4.9 (125)	2.4 (61,0)	-
3/4 150#	3.88 (96,5)	5.0 (127)	2.4 (61,0)	-
1 150#	4.25 (108)	5.3 (135)	2.4 (61,0)	2.8 (71,1)
1-1/2 150#	5.00 (127)	5.6 (142)	2.4 (61,0)	2.8 (71,1)
2 150#	6.00 (152)	6.1 (155)	2.4 (61,0)	2.8 (71,1)
1/2 300#	3.75 (95,3)	5.0 (127)	2.4 (61,0)	2.7 (68,6)
3/4 300#	4.62 (117)	5.4 (137)	2.4 (61,0)	2.8 (71,1)
1 300#	4.88 (124)	5.6 (142)	2.4 (61,0)	2.8 (71,1)
1-1/2 300#	6.12 (155)	6.1 (155)	2.4 (61,0)	2.8 (71,1)
2 300#	6.50 (165)	6.5 (165)	2.4 (61,0)	2.9 (73,7)
1/2 600#	3.75 (95,3)	5.0 (127)	2.8 (71,1)	2.7 (68,6)
3/4 600#	4.62 (117)	5.4 (137)	2.8 (71,1)	2.8 (71,1)
1 600#	4.88 (124)	5.6 (142)	2.8 (71,1)	2.8 (71,1)
1-1/2 600#	6.12 (155)	6.1 (155)	2.8 (71,1)	2.8 (71,1)
2 600#	6.50 (165)	6.5 (165)	2.8 (71,1)	2.9 (73,7)
1/2 900/1500#	4.75 (121)	5.4 (137)	2.8 (71,1)	2.8 (71,1)
3/4 900/1500#	5.12 (130)	5.4 (137)	2.8 (71,1)	2.8 (71,1)
1 900/1500#	5.88 (149)	6.1 (155)	2.8 (71,1)	2.8 (71,1)
1-1/2 900/1500#	7.00 (178)	6.4 (163)	2.8 (71,1)	2.8 (71,1)
2 900/1500#	8.50 (216)	7.4 (188)	2.8 (71,1)	2.9 (73,7)
1/2 2500#	5.25 (133)	5.6 (142)	2.8 (71,1)	2.8 (71,1)
3/4 2500#	5.50 (140)	5.4 (137)	2.8 (71,1)	2.8 (71,1)
1 2500#	6.25 (159)	6.1 (155)	2.8 (71,1)	2.8 (71,1)
1-1/2 2500#	8.00 (203)	7.3 (185)	2.8 (71,1)	2.9 (73,7)
2 2500#	9.25 (235)	7.8 (198)	2.8 (71,1)	2.9 (73,7)

## How to Order

Model Number	Seat Configuration	Body Material	Inlet Size	Inlet Type	Outlet Size	Outlet Type	Trim*	Seat Material	Packing
HK02	2 = Soft Seat	Y = A182 316L	3 = 1/2" (DN15)	C = 150#RF	3 = 1/2" (DN15)	C = 150#RF	3 = 316 NACE	3 = PEEK**	2 = Teflon**
		3 = A182 316L Nace	4 = 3/4" (DN20)	D = 300#RF	4 = 3/4" (DN20)	D = 300#RF	4 = 316	4 = C-PEEK	3 = Graphite
		6 = Duplex A182 F51	5 = 1" (DN25)	H = 900/1500#RF	5 = 1" (DN25)	H = 900/1500#RF	B = Monel		
		7 = Inconel 625	6 = 1-1/2" (DN40)	K = 2500#RF	6 = 1-1/2" (DN40)	K = 2500#RF	D = Hast-C		
		I = Incoloy 825	7 = 2" (DN50)	M = 300#RTJ	7 = 2" (DN50)	M = 300#RTJ	Y = 316L		
		H = Hastelloy-C		N = 600#RTJ		N = 600#RTJ	A = 316L NACE		
		J = Inconel 625		P = 900/1500#RTJ		P = 900/1500#RTJ	6 = I-625		
		K = Low Temp CS A350 LF2		R = 2500#RTJ		R = 2500#RTJ	7 = I-825		
		M = Monel 400					C = Super Duplex		
		N = CS A105 Nace (Forged)					M = Duplex		
		P = CS A105 (Forged)					G = Alloy 20		
		U = 316 SS							
		D = 316 SS NACE							
		X = Alloy 20							

\* Standard Trim will match body material, except CS Bodies which include 316SS Trim Standard  
 \*\* Standard