

MODEL VS_(x)
ANSI B16.1 Slip-On, Raised Face Flanges - Class 125 or 250
DESCRIPTION AND GENERAL PERFORMANCE SPECIFICATIONS

The V-Cone® flowmeter is a patented, differential pressure type flow measurement device. A cone is positioned in the center of the pipe to increase the velocity of the flowing fluid and create a differential pressure. This pressure difference can be measured and used to accurately interpret flowrate. Two taps are provided on every V-Cone to allow sensing of the high and low pressures. A typical V-Cone application can follow these general performance specifications:

- Accuracy: up to ±0.5% of rate
- Repeatability: ±0.1%
- Turndown: 10:1
- Standard Betas: 0.45 through 0.85
- Headloss: Percentage of differential pressure produced varies with beta ratio.
- Installation: Typically 0-3 diameters upstream and 0-1 diameters downstream.

Model VS Bulletins
ANSI B16.5 Slip-on, RF Flanges
 24509-32 Class 150 or 300
 24509-33 Class 600 or 900
 24509-34 Class 125 or 250



The V-Cone is manufactured under a quality management system that is certified to ISO 9001:2008.

* Each V-Cone is sized for the intended application. Specific performance ratings must be obtained through the sizing process.

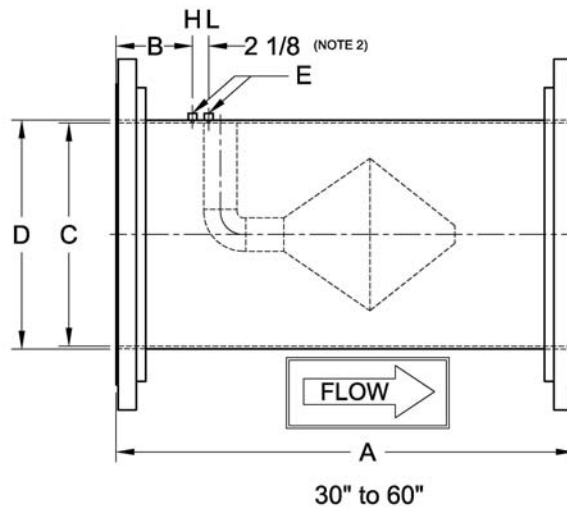
MODEL VS_(x) DIMENSIONS

DIMENSION TABLE

Size	A (Note 1)		B		C-Stainless (Note 2)		C-Carbon (Note 2)		D		E (Note 2)
	inch	mm	inch	mm	inch	mm	inch	mm	inch	mm	NPT
30	60	1524	10	254.0	29.25	743.0	29.25	743.0	30	762	½
36	62	1524	10	254.0	35.25	895.4	35.25	895.4	36	914	½
48	78	1829	12	304.8	47.25	1200	47.25	1200	48	1219	½
60	84	2134	12	304.8	59.25	1505	59.25	1505	60	1524	½

1. Overall length (A) tolerance: 30" to 60", ±0.25" (±7mm).
2. Typical values shown.
3. Wall pressure ports are required for vertical up flow applications.



CONFIGURATION SHEET

MODEL NUMBER CONFIGURATION VS(x)

Type	Size		Materials‡		Pipe Schedule		End Connections		Fittings	
VS										
	30	30"	Q	S304	A	10	30	CL 125 RF SO	N	NPT
	36	36"	L	S304L	B	20	31	CL 250 RF SO	S	Socket
	48	48"	A	S316L	D	Std				
	60	60"	N	S304 Tube, Cone, Support & Couplings	E	40				Several types of fittings
				CS Steel Flanges	F	80				
				Flanges painted	J	100				
			S	CS Tube & Flanges	K	120				
				S304 Cone, Support, & Couplings	L	140				
				Epoxy Coated Blue (excluding cone)	G	160				
			U	CS Tube & Flanges	H	XXS				
				S304 Cone, Support, & Couplings	M	10S				
				Coating / Painting Per Customer Req.	P	XS				

‡Other materials can include:
 HASTELLOY C-276 S321H
 DUPLEX 2205 INCONEL 625
 CHROMEMOLY P22/P11
 MONEL K400/K500
 CARBON STEELS
 A350, A333, API5L, A106B

Example: VS30ND30N V-Cone 30 inch line size, S304 schedule std pipe, painted CS ANSI CL 125 RF slip on flanges, 1/2" NPT fittings

STANDARD PIPE SCHEDULES

Stainless Steel		Carbon Steel	
Size	Std.	Size	Std.
30" and up	D	30" and up	D

ABBREVIATIONS

ASME	American Society of Mechanical Engineers		
NPT	National pipe taper		
SS	Stainless steel	RF	Raised Face
CS	Carbon steel	SO	Slip On

Technical questions can be answered through a local representative or through our application engineers.

MANUFACTURING STANDARDS

McCrometer's welders and welding procedures are qualified in accordance with ASME Section IX. All meters are visually inspected for weld defects. Specific customer requirements can be complied with upon request.

The welding can be in accordance with:

- ASME Section VIII
- ASME B31.1
- ASME B31.3

Non-destructive testing can include:

- Hydrostatic Pressure Testing
- Penetrant Examination
- Radiographic Examination
- Positive Material Inspection
- Magnetic Particle Examination

REPRESENTED BY:

